

# BEPCO, INC

## WATER PUMPS

### PRODUCT & INFORMATION



# WARRANTY POLICY

The manufacturer warrants to the original purchaser that its water pumps will be defect free in workmanship and materials under normal use and service. This warranty shall be extended for one year or 100,000 miles, whichever comes first.

The manufacturer's products claimed to be defective should be brought to the attention of the route man or shipped to the factory within 30 days after the defect is discovered.

The manufacturer's products returned to the factory should be labeled with a warranty tag, and identified as to reported operational problems.

The manufacturer will, at the original purchaser's option, repair or replace the product or allow full credit at the current purchase price for any product determined to be defective by the manufacturer's quality inspection team if the unit is within the mileage and time allowances and properly installed and maintained. Transportation charges on replacement parts will be at the manufacture's expense.

## WARRANTY DISCLAIMER

**The foregoing Warranty and the obligations and liability of the manufacturers' are exclusive and are given in lieu of: 1) all other warranties, guarantees, or liabilities, either express or implied, including, without limitation, the implied warranties of merchantability and fitness for a particular purpose; and 2) any obligation, liability, right, claim, or remedy in contract or tort, whether or not arising from the manufacturers' negligence or strict liability. Any legal right to assert any claim in tort, including, without limitation, claims of negligence or strict liability or failure to warn, are expressly waived by purchaser in consideration for the foregoing express warranty and a purchase price which has been reduced in exchange for these limitations of liability. Any remedies of the purchasers shall be limited to those provided herein to the exclusion of any and all other remedies, including, without limitation, loss of use, revenue, or incidental or consequential damages.**

**The manufacturer and purchaser agree to extend the terms and limitation of waiver/disclaimer and all other provisions set forth above to each party's respective parent companies, subsidiaries, affiliates, assigns, successors in interest, subcontractors, and component part manufacturers and suppliers a every tier, as third party beneficiaries of the terms above.**

**The parties intend that this disclaimer/waiver of liability set forth above be construed broadly to achieve the intended objectives of imposing liability limitations.**

# DISCLAIMER

All of the pictures, specifications, descriptions, text and other data in this catalog have been carefully checked and researched with original manufacturer's catalogs at the time of publication. We assume no responsibility should any information be deemed as incorrect, and reserve the right to make changes at any time without notice.

Manufacturer's names, symbols, numbers and descriptions are used for reference purposes only. It is not implied that any part listed is the product of these manufacturers.

NOTE: Any references made herein to Allis Chalmers®, Bendix®, Case®, Caterpillar®, Chevrolet®, Clark®, Continental®, Cummins®, Detroit Diesel®, Dodge®, Ford®, GMC®, John Deere®, Hino®, International®/Navistar®, Isuzu®, Mack®, Massey-Ferguson®, Mercedes Benz®, Perkins®, Volvo-White®, are purely for identification purposes only.

All of the above companies are registered trademarks or trade names of their respective companies. We do not intend to represent any parts shown as products manufactured by the above companies.



**BEPCO®, Inc. • 2475 South Stratford Road • Winston-Salem, NC 27103  
800-735-1154 336-760-0740 fax 336-768-1154**

Copyright: No part of this publication may be reproduced, stored in a retrievable system, or transmitted in any form or by means of electronic, mechanical, photocopying, recording or otherwise, without the written permission of the publisher. This includes text, figures, photographs and tables.

Year/Make	Application/ Engine	BEP CO PART NUMBER	OEM Number	Casting Number
<b>Allis Chalmers</b>				
	<b>Combine</b>			
	<b>Forklift (4 Cyl.)</b>			
	Continental Eng. F162, w/2 Groove Pulley	7032X	994164	F600K520
	Continental Eng. F163, w/3 Groove Pulley	7033X	874617	F600K519
	<b>Forklift (6 Cyl.)</b>			
	Continental Eng. F226, F227, F244, F245, w/2 Groove Pulley	7034X	994173	F162K500
	<b>2 Cyl.</b>			
1955-40	HD-5 Diesel Left Hand	7103X	5135595	5135601
1955-40	HD-5 Diesel Right Hand	7104X	5135596	5135602
	<b>3 Cyl.</b>			
1955-40	HD-7 Diesel Left Hand	7103X	5135595	5135601
1955-40	HD-7 Diesel Right Hand	7104X	5135596	5135602
	<b>6 Cyl.</b>			
	HD-7 Diesel Left Hand	7103X	5135595	5135601
<b>Case</b>				
	<b>Combine (4 Cyl.)</b>			
	Model 150 w/400 Eng.	7030X	G-11956	A-28860
	Model 600 w/G188B Eng.	7030X	G-11956	A-28860
	Model 600 w/G188D Diesel Eng.	7031X	A146584	N/A
	<b>Tractor, Loaders &amp; Crawlers</b>			
1965-61	310D, 310F Utility, 430, 440, 530, 540, 540C, 541, 541C Gas Models	7030X	G-11956	A-28860
1965-59	200B, 210B, 300B, 310B, 400B, 500B, 600B, 610B Gas Models	7030X	G-11956	A-28860
1958	200, 210, 300, 310, 400, 500, 600, 610 Gas Models	7030X	G-11956	A-28860
1957-55	300, 320, 350, 351 Gas Models	7030X	G-11956	A-28860
1955-48	VA, VAC Series (After No. 72-E07778	7030X	G-11956	A-28860
	430, 470, 480, 530, 570, 580B, 630 Tractors w/G188D Diesel Eng.	7031X	A146584	N/A
	310E, 310F, 310G, 350, 450 Crawler w/G188D Diesel Eng.	7031X	A146584	N/A
	480C, 580C, 1845 Tractor Loaders w/G188D Diesel Eng.	7031X	A146584	N/A
	1150, 1155, 1255 Windrowers w/G188D Diesel Eng.	7031X	A146584	N/A

Year/Make	Application/ Engine	BEPCO PART NUMBER	OEM Number	Casting Number
<b>Caterpillar</b>				
	3208, 636 Cu. Inch Eng. With No Pulley	7001X	9N6147	9N3076
	3208, 636 Cu. Inch Eng. w/pulley	7002X	2W1225, OR0781, 9N6147	9N3076
	3208, 636 Cu. Inch Eng. Threaded Pulley for Fan Clutch.	7004X	2W1227	9N3076
	1140 & 1160, Models: 1500, 1800 w/3150 eng.	7005X	9L7660, OR0644	9L8323
	3406 B&C, 893 Cu. Inch. Flat Gear w/curved Teeth	7006X	7W7019, OR8217, 7C4957, 1OR0482	9N5034
	3406E w/Dome Gear & Curved Teeth	7006EX	613890-OR4120, 1OR0483, 613890- OR8218E	100-7479, 9N5034-01, 102- 5946, 135-4918
	3406E, C15, C16 w/Straight Tooth Dome Gear	7006EGX	1OR0484, OR9869	161-5718
	3406 & 3406E Back Plate Kit	7006BPX	7C9222	N/A
	3306 Angled Teeth w/Off Set Holes & 3 1/8" Bearing	7007X	6N8413, OR1251	7N196, 1W9619, 172-7829, 1543945
	3306 Straight Teeth w/Off Set Holes	7007GX	OR8532, 4P9862, OR9493, OR0997	7N196, 1W4619, 172-7827, 1543945
	3208 w/press on pulley	7008X	OR0781	9N138
	3176 Aluminum Casting	7009X	1025844, 7E8554, 9Y4361, OR8766, OR4117	103-0745
	3304 w/Straight Holes & 2 11/16" Bearing	7010X	7N5909	2P671
	3176B, C10, C12, C13 Acert Cast Iron Housing	7011X	1006944, OR0705, OR3709, OR8767	105-4213, 105- 4214, 176-6999
	3116 w/4 3/8" Pulley	7012X	OR3007, 4W0253, 4P3683, 9Y4879, OR1013	4P3681
	3116 w/Fittings	7012KX	OR3007, 4W0253, 4P3683, 9Y4879, OR1013	4P3681
	3306 Reminds you of 7007 Except has 2 3/8" Bearing	7013X	OR9497, OR1003	7N196, 1W4619
	3306 w/Solid Gear & 2 11/16" Bearing Similar to 7007	7014X	OR9785, OR1002	7N196, 1W4619
	Same as above, except with Straight Teeth	7014GX	OR1002	
	3116 w/3 3/4" Pulley	7015X	7W3780	4W0249
	C7, Similar to 7016M Except has Hub	7016X	N/A	203-6093-01
	C7, 3126 w/Multi Groove Pulley	7016MX	CAT. NO. 227- 4299	203-6093-01
	C17, C18 Acert, C27, Reminds you of 7006EG except Larger Housing, w/Straight Teeth Dome Gear	7017X	1OR-3326, CAT#246-3132, 280- 7374, 314-5155	246-3131, 246- 3137, 224-3237

	3116-3126 Engine	7019X		128-5121
	3306, 40LH Tooth Gear	7021X	OR2853, 2W8003	1W6558, 6N8970
	<b>Forklift (4 Cyl.)</b>			
	Continental Eng. F162, w/2 Groove Pulley	7032X	994164	F600K520
	Continental Eng. F163, w/3 Groove Pulley	7033X	874617	F600K519
	<b>Forklift (6 Cyl.)</b>			
	Continental Eng. F226, F227, F244, F245, w/2 Groove Pulley	7034X	994173	F162K500

Year/Make	Application/ Engine	BEP CO PART NUMBER	OEM Number	Casting Number
<b>Chevrolet Truck</b>				
	<b>Medium &amp; Heavy Duty (6Cyl.)</b>			
1989-88	4.8L (292), P4 Series	7143X	10112691	465802
1987-81	4.8L (292), Series 50, 60	7143X	474056	465802
1984-83	4.8L (292), Series 50, 60, School Bus	7143X	474056	465802
1980-74	4.8L (292), Series 50, 60, 2nd Design	7143X	357262	352199
1979	Titan 90 Series w/54 BBC 6-71 Diesel Eng. Right Hand Mount	7104X	5135596	5135602
1979	Titan 90 Series w/54 BBC 6V-92T, 6V-92TT, 8V-92T Diesel Eng. Left Hand Mount	7103X	5135595	5135601
1978-73	Series 50, 60, 65 w/6-71 Diesel Eng. Right Hand Mount	7104X	5135596	5135602
1978-73	Series 50, 60, 65 w/6-71 Diesel Eng. Left Hand Mount	7103X	5135595	5135601
1977-70	Series 90 w/6-71 Diesel Eng.	7104X	5135596	5135602
	<b>Medium &amp; Heavy Duty (8Cyl.)</b>			
2004-2003	8.1L, Kodiak C4500, C5500, C6500, C7500, C8500	7144X	88893907	N/A
2002-2001	8.1L, C6, C7, Kodiak, B7 School Bus	7144X	1255863, 88893907	12558870
2000-99	7.4L, B7 School Bus, Kodiak C6, C7, (w/Threaded Hub & Bypass Tube)	7145X	12456328	N/A
1998-96	6.0L (366), 7.0L (427) B7 School Bus, C5, C6, C7 Series w/Screw on Hub	7123X	10140667, 12529192	10241634, 14001939
1998	6.5L (395), B7 School Bus	7129X	12534772, 5744662	12557071
1997	6.0L (366), F6, 7 Series w/Screw on Hub	7123X	10140667, 12529192	10241634, 14001939
1997	6.5L (395), B7 School Bus, Exc. Hazard Warning Switch	7129X	12534772, 5744662	12557071
1995-90	6.0L (366), 7.0L (427) P6 School Bus, 50, 60, 70 Series w/Screw on Hub	7123X	10140667, 12529192	10241634, 14001939
1990-73	5.7L (350), Series 40, 50, 60	7146X	10048921, 6258551	330813, 330813P
1990-81	6.0L (366), 7.0L (427) School Bus, 60, 70 Series w/Screw on Hub	7116X	10074182	14001939
1982-79	7.4L (454), Series 60, 70	7116X	10074182	14001939
<b>Clark Truck &amp; Tractor, (4Cyl.)</b>				
	Continental Series F162 Engine Pump w/Back Plate and 2 Groove Pulley	7035X	865774, F162K-3653	F400K-422

	Continental Series Y400 Engine Pump w/Back Plate and 2 Groove Pulley	7036X	865707, Y400K-3612	Y400K-410
<b>Continental Motors, (4Cyl.)</b>				
	Series F162 Pump Using F400K-422 Body, w/Back Plate and 2 Groove Pulley HD206K-305	7035X	F162K-3653	F400K-422
	Series Y400 Pump Using Y400K-410 Body, w/Back Plate and 2 Groove Pulley Y91K-336	7036X	Y400K-3612	Y400K-410



Year/Make	Application/ Engine	BEP CO PART NUMBER	OEM Number	Casting Number
<b>Cummins Diesel</b>				
1989-68	Dina w/front engine 155 6cyl & 210 8cyl	7043X	A-34079-A05, AR61788	555260
1989-68	Dina w/Rear engine 155 6cyl & 210 8cyl	7045X	AR-61789, 14079-D105, 34079-B105, 377411	555260
	KT/KTA 1150	7040X	3022920	206964, 206864
	4 11/16" Multi Groove Pulley & 4 1/2" Impeller	7041X	3051368, AR10961	3004745
	Big Cam, 4 11/16" Pulley & 4 1/2" Impeller, w/7 Hole Casting, Can use 7052	7042X	3051378	219040
	Big Cam	7044X	3007290	210238
	Cummins 4000 (14.0)	7044X	3007290	210238
	220, NHT, NHRS, w/5 1/8" Bore	7047X	BM50345, BM50356	165135, 115498
	220, Smaller top Bearing w/Snap Ring in Second Slot	7047SX	N/A	N/A
	220, NRT, NROT, w/5 1/8" Bore	7048X	BM71040	165135
	Small Cam FFC, w/4 11/16" Multi Groove Pulley & 4" Impeller	7049X	3024671	210238
	Small Cam w/2 Groove Pulley & 4 1/2" Impeller	7050X	3045161	218274
	NT & NTC 250 5 1/2" Bore & 9 1/4" Shaft	7054X	AR4547	196830
	NT & NTC 250 5 1/2" Bore & 9 7/8" Shaft	7055X	AR4548	196830
	NTC Formula 230 (Short Suitcase w/2 Groove Pulley & 4" Impeller)	7057X	3022471, AR45073	3002520
	NTC Formula 230, (Short Suitcase w/4 11/16" Multi Groove Pulley & 4" Impeller)	7062X	3027882	3002520
	V, VT 555, V8	7070X	AR61116	553928
	H, HF, HR, HRS, NFT, NRT, NRTO, NH220, NHE180, NHE195, NHE220, NHS, NHRS (w/High Mounted Fan) (w/out Pulley) ( Right Hand Mounted Pump)	7077X	BM50466, BM76506	132423, 115481
	H, HF, HR, HRS, NFT, NRT, NRTO, NH220, NHE180, NHE195, NHE220, NHS, NHRS (w/Pulley) ( Right Hand Mounted Pump)	7077PX	BM54327	132423, 115481
	V/VT/VTA 1710	7078X	AR-11229RX	181094H
	KT/KTA 1710, 2300	7079X	N/A	3030489, 3030490
	<b>600 Series</b>			
	ISX eng. Has 10 Groove Pulley at Top Step	7083X	3800495, 4089158RX, 4089908	2201-10
	ISX eng. Has 12 Groove Pulley at Top Step	7084X	3800495	2201-10MJ

	<b>855 Big Cam III</b>			
	Ford LTL9000, GMC Brigadier (Suitcase Pump) (5 1/2 Bore) (Not Suitable for Horizontal Eng.) w/4 11/16" Multi Groove Pulley & 4 1/2" Impeller, Vented	7075X	3027174	3045163
	<b>855 Series</b>			
	NH 250 Military (5 1/2" Bore Shaft) w/pulley	7080X	AR51360	202963
	<b>88 Big Cam IV</b>			
	NTC-300, 315, 350, 365, 400, w/Multi Groove Pulley	7060X	3803138, 3052836, 3062928, 3803030	3062899
	NTC-300, 315, 350, 365, 400, Idler w/Multi Groove Pulley	7069X	3062931, 3801234, 3062930	3064201R
	NTC-300, 315, 350, 365, 400, Idler w/Stamped Pulley	7071X	3065000	N/A
	NTC-300, 315, 350, 365, 400, Idler w/Multi Groove Pulley & Bracket	7074X	3062930	N/A
	<b>B Series</b>			
	B Series, ISB, 3.9L 4cyl, 5.9L 6cyl. New Style Pulley w/out lip	7063X	3903749, 3913432, 3286278, 3802358, 3802970, 3802971	3903357, 3283602
	B Series, 3.9L 4cyl, 5.9L 6cyl. Old Style Pulley w/lip	7063AX	3003731, 3802004	3903357
	<b>Big Cam I, II</b>			
	NTC290, NTC350, NTC400, Formula 290, 350 (Suitcase Pump) w/4 11/16" Multi Groove Pulley & 4 1/2" Impeller, Vented	7052X	3022474, 3801788, AR45184	218274
	Big Cam, Multi Groove Idler Pulley	7059X	AR45189, 3064919	215397
	<b>Big Cam III</b>			
	NTC300, 350, 400: Formula 300, 350, 400, 475 (Suitcase Pump) w/4 11/16" Multi Groove Pulley & 4" Impeller	7061X	3004923	218274
	<b>Big Cam IV</b>			
	300, 350, 400, Fleet 300, NTC-Formula 300, 350 400 (w/4 1/2" Multi Groove Pulley & 4 1/4" Impeller) Vented 7059X Idler Pulley	7064X	3801708, 3045943RX	3045163, Made in UK 93810
	<b>C Series</b>			
	In-Line 6 Cyl.	7076X	3802081, 3804883RX, F3HZ8501B, 3286293	3903357, 3913439
	8.3L, Long Noise	7076LX	3800976, 3800974	1793C, 1926-10C, 2369-10C
	ISC & ISL series, Similar to 7076 except has Larger Casting at Mount w/Larger Impeller.	7082X	3286293, 3973114, 3804927, 3940052, 4089647(NX) 3964791	2370-10C, 2857-10C, 3940052
	<b>Cummins FFC</b>			

	NTC270-CT, NT855-C280, NTC290, NTC290-R, NTC855- C310, NT310, NTC350, NTA855- C360	7051X	3000886, 3801784, AR45090, AR8855	210238, 219040
	2 Groove Idler Pulley	7058X	AR8851, 3064920	208118
	<b>L10 &amp; M11 Series</b>			
	LTA10, 240, 270, 300, w/4 hole Mount up to 1991	7066X	3801840, 3803402	3035157, 3039182
	L-10E-MTA 11-330E w/3 Hole Mount, Long Shaft	7072X	3803403	3882615
	ISM, M11 w/3 Hole Mount, Short Shaft	7072SSX	3800745-RX, 3800745, 4955708NX	3882615
	Multi Groove Idler Pulley	7067X	3034969, 3062602	3064201R, 3060884
	<b>N14</b>			
	310, 330, 350, 370, 410 w/Multi Groove Pulley	7068X	3803605, 3803361	3069644, 3076523
	N14 - Volvo	7081X	3804826	3804024
	N14 Idler Pulley	7073X	3066330	N/A
	<b>Pancake Type w/5 1/2" Bore</b>			
	NH, NT & NTC Non FCC, NH230, NH250, NHC270, NHE225 Diesel, NT280, NT300 , NT310, NT335, NT380, NTA380, NTC335, NTC350, NTC380, (Non FCC) w/2 belt Pulley	7053X	AR4284	196845
	NH, NT & NTC Non FCC, NH230, NH250, NHC270, NHE225 Diesel, NT280, NT300 , NT310, NT335, NT380, NTA380, NTC335, NTC350, NTC380, (Non FCC) w/out Pulley	7065X	AR4283	196845
	<b>VT 903</b>			
	w/3 Belt Pulley	7056X	AR5664, (AR9931)	196930
	Cummins, Dodge 6.7 ISB 2007-2012	7098X	2881804, 4855359, 68003402AA, 3959229	451031/02
	Cummins, Dodge 6.7 ISB 2004-2007	7099X		2894-10C

Year/Make	Application/ Engine	BEP CO PART NUMBER	OEM Number	Casting Number
<b>DETROIT DIESEL</b>				
	50 & 60 Series			
	Front Mount, Before 12/90	7121X	23509067 R23514989 23505019	23505018, 8929511
	Rear Mount, After 12/90 (w/ 1/4" Pipe Port)	7122X	23505895, R- 3520136, R3505895	23505894, 23516416
	w/6 Vane Impeller, High Capacity (3/8" Pipe Port)	7126X	23522707	23517027
	w/6 Vane Impeller, High Capacity (3/8" Pipe Port) w/Steel Back Plate	7126SX	23522707	23517027
	w/6 Vane Impeller, High Capacity, Kangaroo Pouch.	7127X	23526039	23522721
	EGR, 14L	7141X	R23531245	23530427
	EGR, 14L	7142X	23531258	23530429
	53 Series			
	Left Hand	7101X	5144685 23506003	5144688
	Right Hand	7102X	5144687 5178658 23506007	5144689
	71 Series			
	3, 4, 6 Cyl. In Line Engs. (Exc. Turbo) (Left Hand Pump)	7103X	5135595 5149706 23506723	5135601, 5178317
	3, 4, 6 Cyl. In Line Engs. (Exc. Turbo) (Right Hand Pump)	7104X	5135596 5149707 5178318 23506735	5135602, 5149707, 5178318, 8920925
	In-Line A & B Engs. Turbo (Left Hand) High Capacity	7113X	5149710, 23506204	5182069
	In-Line A & B Engs. Turbo (Right Hand) High Capacity	7114X	5149708 23506711	5182070
	V-6 & V-8 Engines, Non Turbo, Standing Pump w/2 Outlets pointing straight Down, Standard Capacity (w/Bolt on Back Cover)	7105X	5149328, 23501938	5117921, 5106180, 5136455, 5106160
	V-6 & V-8 Engines, Non Turbo, Running Pump w/2 Outlets at 45 Degree Angles in Opposite Directions, Standard Capacity (w/ Bolt on Back Cover)	7106X	5149329 23501939	5142273
	V-6 & V-8 Engines, Turbo, Standing Pump w/2 Outlets pointing straight Down, High Capacity (w/Bolt on Back Cover)	7107X	5149326 23506790	5135455, 5106180, 5136455, 5106160
	V-8 Engines, Turbo, Standing Pump w/2 Outlets pointing straight Down, High Capacity (w/Reverse Gear & Bolt on Back Cover)	7118X	5149382 23506670	5135455

	V-8 Engines, Turbo, Running Pump w/2 Outlets at 45 Degree Angles in Opposite Directions, High Capacity (w/Bolt on Back Cover)	7108X	5149327 23506791	5142273
	V-8 Engines, Turbo, Running Pump w/2 Outlets at 45 Degree Angles in Opposite Directions, High Capacity (w/Reverse Gear & Bolt on Back Cover)	7115X	5149381 23506698	5142273
	8.2L			
	8 Cyl. Diesel, w/Out Heater Outlet Provision	7119X	8922302	8920383, 8924657
	8 Cyl. Diesel, w/Heater Outlet Provision	7120X	8928672	8828804
	92 Series			
	V-6 & V-8 Engines, Walking Pump w/1 Outlet pointing straight down & 1 Outlet at 45 Degree Angle, w/Snap Ring Back Cover	7109X	8922336 8921105 23506602	8921100, 8922325
	V-6 & V-8 Engines, Walking Pump w/1 Outlet pointing straight down & 1 Outlet at 45 Degree Angle, w/Snap Ring Back Cover & Reverse Gear	7124X	23506604	8921100, 8922325
	V-6 & V-8 Engines, Running Pump w/2 Outlets at 45 Degree Angles in Opposite Directions, w/Snap Ring Back Cover	7110X	8922335 8921104 23506623	8921099, 5101162
	V-6 & V-8 Engines, Walking Pump w/1 Outlet pointing straight down & 1 Outlet at 45 Degree Angle, w/Bolt on Back Cover	7111X	5149320	5101802
	V12 Series			
	Standing, w/bolt on Back Cover & w/Heater Provision	7112X	5149321 23506763	5145089
	V16 Series	7125	23501947	8922723-7, 5140009
	<b>Detroit Diesel Accessory Drives</b>			
	60 Series, Accessory Drive, w/2 Belt Pulley	9160X	23509200	23509201
	60 Series, Accessory Drive, w/Multi Groove Pulley	9161X	23509201	23509201
	60 Series, Accessory Drive, w/out Pulley	9162X	23509200	23509201
	60 Series Accessory Drive Longer Housing than 9162X	9163X		

Year/Make	Application/ Engine	BEPKO PART NUMBER	OEM Number	Casting Number
<b>Dodge Trucks</b>				
	<b>A100 Van (L6)</b>			
1970-69	2.8L (170), 3.2L (198) 3.7L (225)	7086X	2808679	2883663
1968-64	2.8L (170), 3.7L (225)	7086X	2196910 3420050	2128284, 2863063
	<b>B Series Van (L6)</b>			
1987-71	3.2L (198) 3.7L (225)	7086X	4131243 4106034 3420050 2808679	4104553, 4095700, 0910416, 2863063
	<b>D Series Trucks (L6)</b>			
1993-89	5.9L (360) Cummins Turbo Diesel	7063X	4429404	1927-10
1987-61	2.8L (170), 3.2L (198) 3.7L (225)	7086X	4131243 4106034 3420050 2808679 2196910	4104553, 4095700, 0910416, 2863063, 2883663, 2128284
	<b>Dakota (V6)</b>			
2003-93	3.9L (239)	7087X	53021018AB 53021018 53020280	53020135
	<b>Dakota (V8)</b>			
2003-93	5.2L (318), 5.9L (360)	7087X	53021018AB 53021018 53020280	53020135
	<b>Durango (V6)</b>			
1999-98	3.9L (239)	7087X	53021018AB 53021018AC 53021018 53020280	53020135
	<b>Durango (V8)</b>			
2000-98	5.2L (318), 5.9L (360)	7087X	53021018AB 53021018 53020280	53020135
	<b>P100, 200, 300 Series Van (L6)</b>			
1974-67	3.7L (225)	7086X	3420050 2808679 2196910	2863063, 2883663, 2128284
	<b>Ram 2500, 3500 Truck (L6)</b>			
2007-94	5.9L (360) Cummins Turbo Diesel	7063X	4723690 5010964AA 5010964AB 3286278RX	1927-10
	<b>Ram 1500, 2500, 3500 Truck (V6)</b>			
2001-94	3.9L (239)	7087X	53021018AB 53020280	53020135
	<b>Ram 1500, 2500, 3500 Truck (V8)</b>			

2001-94	5.2L (318), 5.9L (360)	7087X	53021018AB 53021018 53020280	53020135
	<b>Ram 1500, 2500, 3500 Van (V6)</b>			
2003-99	3.9L (239)	7087X	53021018AB 53020280	53020135
	<b>Ram 1500, 2500, 3500 Van (V8)</b>			
2003-99	5.2L (318), 5.9L (360)	7087X	53021018AB 53021018 53020280	53020135
	<b>Ramcharger (L6)</b>			
1980-74	3.7L (225)	7086X	4131243 4106034 3420050 2808679	4104553, 4095700, 0910416, 2863063, 2883663, 2128284
	<b>Ramcharger (V8)</b>			
1993	5.2L (318), 5.9L (360)	7087X	53021018AB 53021018 53020280	53020135
	<b>Series 400-1000</b>			
1977-67	3.7L (225)	7086X	4131243, 4106034, 3420050, 2808679	4104553, 4095700, 0910416, 2863063, 2883663, 2128284
	<b>Sprinter (L5)</b>			
2006-2004	2.7L 2500, 3500	7085X	5138057AA	N/A
	<b>W Series Truck (L6)</b>			
1993-89	5.9L (360) Cummins Turbo Diesel	7063X	4429404 4723690	3903357
1977-69	3.2L (198), 3.7L (225) Series 400 Thru 600	7086X	4131243 4106034 3420050 2808679	4104553, 4095700, 0910416, 2863063, 2883663, 2128284
1968-67	2.8L (170), 3.7L (225) D400, 500; P400; S400, 500; L600	7086X	4131243 4106034 3420050 2808679	4104553, 4095700, 0910416, 2863063, 2883663, 2128284
	<b>W Series Truck (V6)</b>			
1993	3.9L (239)	7087X	53021018AB 53021018 53020280	53020135
	<b>W Series Truck (V8)</b>			
1993	5.2L (318), 5.9L (360)	7087X	53021018AB 53021018 53020280	53020135

Year/Make	Application/ Engine	BEPKO PART NUMBER	OEM Number	Casting Number
<b>Ford Tractor &amp; Industrial</b>				
	<b>3 Cyl.</b>			
74-71	All 2000 thru 7000 Series Gas or Diesel (w/Single Groove Pulley & 4.100" Impeller)	7330X	D5NN-8501E	D4NN-8508A, D5NN-8505A
1970-65	2000, 3000, 4000 Series Gas or Diesel (w/Single Groove Pulley & 3.500 Dia. Impeller)	7331X	C5NN-8501A, D5NE-8501A	C5NE-8508A
	<b>4 Cyl.</b>			
1996-81	Models (5110, 5610, 6610, 6810, 7410, 7610, 7710 All 11/88 & Up) 7010 4/96 & UP (All w/Threaded 2 Belt Pulley)	7333X	FAPN-8A513AA	E8NN-8505
	134, 172, 192 Gas or Diesel	7332X	D1JJ-8501C	N/A
1981-75	2000, 3000, 4000, 5000, 7000 (2600, 3600, 4100, 4600, 5600, 5700, 6600, 6700, 7600, 7700 (2310, 2610, 2810, 2910, 3610, 3910, 4110, 4610 All 2/90) w/5/16" & 7/16" Mounting Holes (2 Groove Pulley) (Large Bearing)	7340X	EAPN-8A513A, EGPN-8A513CA	D8NN-8508EB, EAP-8A513-E
1981-75	6700 Thru 7700 w/5/16" & 3/8" Mounting Holes, Same as 7340 Except has Smaller Mounting Holes	7341X	FAPN-8A513AD3	D8NN-8508EB, EAP-8A513-E
1975-71	All 2000 thru 7000 Series Gas or Diesel (w/Single Groove Pulley & 4.100" Impeller)	7330X	C5NN-8501E, D5NN-8501E	D4NN-8508A, D5NN-8505A
1970-65	5000 Gas or Diesel (w/Single Groove Pulley & 3.500 Dia. Impeller) (Can Use 7330X)	7331X	C5NN-8501A, D5NE-8501A	C5NE-8508A
	4310, 4610, 4810, 39 Series (Larger Mounting Holes Than 7331X) (Has Larger Bearing)	7339X	N/A	N/A
1969-65	134, 172 Tractor & Industrial gas Models 600, 700, 800, 900, 2000, 4000 Series Diesel Models	7334X	CDPN-8501C, EAF-8501C	EAF-8505
1964-59	Series 500D, 501D, After Serial #153775; 600D, 601D, 700D, 701D, 2030D, 2031D, 2110D, 2111D, 2120D, 2130D, 2131D w/144 Diesel	7334X	CDPN-8501C, EAF-8501C	EAF-8505
1964-58	Series 800D, 801D, 900D, 901D, 1800, 4030D, 4031D, 4040D, 4110D, 4120D, 4121D, 4130D, 4131D, 4140D w/D172 Diesel	7334X	CDPN-8501C, EAF-8501C	EAF-8505
1964-55	Series 800, 801, 900, 901, 1800, 1801, 4030, 4031, 4040, 4110, 4121, 4130, 4131, 4140 w/172 Gas or L.P.G	7334X	CDPN-8501C, EAF-8501C	EAF-8505



1964-55	Series NAA, 501, 541, 600, 601, 611, 620, 621, 630, 631, 640, 641, 650, 651, 660, 661, 671, 700, 701, 740, 741, 771, 2030, 2031, 2110, 2111, 2120, 2130, 2131 w/134 Gas or L.P.G.	7334X	CDPN-8501C, EAF-8501C	EAF-8505
1957-55	Series NAA, 600, 620, 621, 630, 631, 640, 641, 650, 651, 660, 661, 700, 740, 741 w/134 Kerosene Eng.	7334X	CDPN-8501C, EAF-8501C	EAF-8505
1957-55	800K, 900K w/172 Kerosene Eng.	7334X	CDPN-8501C, EAF-8501C	EAF-8505
1954-53	NAA, Major	7338X	CDPN-8501B	N/A
1952-39	Model 2N, 8N, 9N	7335X	2N-8501, 8N-8501, 9N-8501	N/A
	<b>6 Cyl.</b>			
	4.9L (300) Industrial Eng.	7336X	F6JE-8501BA	F6TE-8505LA
7/1976-68	8000, 8200, 8400	7337X	C9NN-8501B, DHPN-8A513B	C5NE-8505A
7/1976-74	9000, 9200	7337X	C9NN-8501B, DHPN-8A513B	C5NE-8505A

***BLUE PART #'S INDICATE R&R STATUS***

Year/Make	Application/ Engine	BEPCO PART NUMBER	OEM Number	Casting Number
<b>Ford Truck</b>				
	<b>E Super Duty Vans (V-8)</b>			
2002-96	7.3L (446) (F) Direct Injection Turbo Diesel	7320X	F7TZ-8501BRM, F7TZ-8501CRM, F8IZ-8501ARM	1831005C2, 1823611C1
	<b>E 100/350 Van (V-8)</b>			
2003-2000	7.3L (466) (F) E350 Direct Injection Turbo Diesel	7320X	F7TZ-8501BRM, F7TZ-8501CRM, F8IZ-8501ARM	1831005C2, 1823611C1
1999-96	7.3L (466) (F) E250/350 Direct Injection Turbo Diesel	7320X	F7TZ-8501BRM, F7TZ-8501CRM, F8IZ-8501ARM	1831005C2, 1823611C1
1995-94	7.3L (466) (F) E250/350 Direct Injection Turbo Diesel	7314X	F5TZ-8501BRM, F5TZ-8501CRM	1822823C1, 1823423C2
1994-89	7.3L (446) (M) E250/350, Diesel Non-Turbo	7304X	E9TZ-8501C, E4T2-8501B	446430C1
1988-83	6.9L (420) (1) 7.3L (446) (M) E250/350 Diesel	7304X	E9TZ-8501C, E4T2-8501B	446430C1
	<b>Excursion ( V-8)</b>			
2003-2000	7.3 (446) (F) Diesel	7320X	F7TZ-8501BRM, F7TZ-8501CRM, F8IZ-8501ARM	1831005C2, 1823611C1
	<b>F250/350 Pickup (V-8)</b>			
1997-96	7.3L (466) (F) F250/350 Direct Injection Turbo Diesel	7320X	F7TZ-8501BRM, F7TZ-8501CRM, F8IZ-8501ARM	1831005C2, 1823611C1
1995-94	7.3L (466) (F) F250/350 Direct Injection Turbo Diesel	7314X	F5TZ-8501A, B, CRM	1822823C1
1994	7.3L (466) (K) F250/350 Indirect Injection Turbo Diesel	7304X	E4TZ-8501C E9TZ-8501B	446430C4
1994-88	7.3L (466) (M) F250/350 Diesel Non-Turbo	7304X	E4TZ-8501C E9TZ-8501B	446430C4
1993	7.3L (466) (C) F250/350 Turbo Diesel	7304X	E4TZ-8501C E9TZ-8501B	446430C4
1987-83	6.9L (420) (1) 7.3L (446) (Diesel) F250/350	7304X	E4TZ-8501C E9TZ-8501B	446430C4
	<b>Ford Super Duty</b>			
2007-2004	6.0L Diesel, E Series, F Series	7324X	4C3Z-8501ABRM	N/A
June 2004-2003	6.0L Powerstroke, Turbo Diesel	7323X	3C3Z-8501ABRM	N/A
2005-2003	6.0L (V8) Diesel, F650, F750	7323X	4C47-8501AARM	N/A
2000 & Up	F650/750	7322X	YC3Z-8501A	1831576C1
	<b>F53 Stripped Chassis</b>			
1996-95	7.3L (446) Direct Injection Turbo Diesel	7314X	F5TZ-8501BRM, F5TZ-8501CRM	1822823C1

	<b>F59 Stripped Chassis</b>			
1997-96	7.3L (446) (F) Direct Injection Turbo Diesel	7320X	F7TZ-8501BRM, F7TZ-8501CRM, F8IZ-8501ARM	1831005C2, 1823611C1
1995-94	7.3L (446) (F) Direct Injection Turbo Diesel	7314X	F5TZ-8501BRM, F5TZ-8501CRM	1822823C1
1994	7.3L (466) (K) Indirect Injection Turbo Diesel	7304X	E4TZ-8501C E9TZ-8501B	446430C4
1994-89	7.3L (466) (M) Diesel Non Turbo	7304X	E4TZ-8501C E9TZ-8501B	446430C4
	<b>Series 400-1100 (V-6)</b>			
1995-94	6.6L (401) B-C-CF-F800 (w/out Water Pump Mounted Fan)	7311X	F1HZ-8501CRM	FOHN-8508AA
1995-94	6.6L (401) B-C-CF-F800 (With Water Pump Mounted Fan)	7319X	F1HZ-8501DRM	E8HN-8508AB
1993-91	6.6L (401) C600/F800 Diesel (w/out Water Pump Mounted Fan, Exc. 210 H.P)	7311X	F1HZ-8501C	FOHN-8508AA
1993-91	6.6L (401) C600/F800 Diesel (With Water Pump Mounted Fan, Exc. 210 H.P)	7319X	F1HZ-8501D	E8HN-8508AB
1993-91	6.6L (401) 7.8L (476) Diesel B-F-FT-L600/L900 (From 10/1/90) (w/out Water Pump Mounted Fan)	7311X	F1HZ-8501C	FOHN-8508AA
1993-91	6.6L (401) 7.8L (476) Diesel B-F-FT-L600/L900 (From 10/1/90) (With Water Pump Mounted Fan) (Exc. 210 H.P)	7319X	F1HZ-8501D	E8HN-8508AB
	7.8L	7306X	E7HZ-8501A, E8HZ-8501CRM	E7HN-8508AB
1991	6.6L (401) 7.8L (476) Diesel B-F-L600/L900	7307X	E8HZ-8501B	E7HN-8508AA
1990-88	6.6L (401) 7.8L (476) FNH Diesel	7307X	E8HZ-8501B, C	E7HN-8508AA
1987	6.6L (401) F600	7307X	E8HZ-8501CRM	E7HN-8508AA
1987	7.8L (476) CF600/800	7307X	E7HZ-8501B	E7HN-8508AA
	<b>Series 400-1100 (V-8)</b>			
1997-91	7.0L 370, 429	7309X	F1HZ-8501E	F1HE-8505CA
1995-91	7.0L (429) CF800, CFT800 (LPG Gas Only)	7309X	F5HZ-8501AA	F5HE-8505AA
1990-82	7.0L 370, 429	7309X	E5HZ-8501A	E4TE-AA
1981-79	370, 429 B, F600/800	7309X	D9HZ-8501A, E2HZ-8501B	E2TE-8505AA
1981-79	370, 429 C, CT600/800	7309X	D9HZ-8501A, E2HZ-8501B	E2TE-8505AA
1981-79	370, 429 L, LN, LNT, LT, LTS800	7309X	D9HZ-8501A, E2HZ-8501B	E2TE-8505AA

Year/Make	Application/ Engine	BEP CO PART NUMBER	OEM Number	Casting Number
<b>GMC Truck</b>				
	<b>Medium &amp; Heavy Duty (6Cyl.)</b>			
1989-88	4.8L (292), P4 Series	7143X	10112691	465802
1987-78	4.8L (292), Series 50, 60	7143X	474056	465802
1984-83	4.8L (292), Series 50, 60, School Bus	7143X	474056	465802
1980-74	4.8L (292), Series 50, 60, 2nd Design	7143X	357262	352199
1978-73	Series 50, 60, 65 w/6-71 Diesel Eng. Right Hand Mount	7104X	5135596	5135602
1978-73	Series 50, 60, 65 w/6-71 Diesel Eng. Left Hand Mount	7103X	5135595	5135601
1974-39	450-900 Series, 3-71, 4-71, 6-71, Diesel Eng. Exc. 6-71T, Right Hand Pump.	7104X	5135596	5135602
	<b>Medium &amp; Heavy Duty (V-8)</b>			
2004-2001	8.1L (496) (G) C4500 Thru C8500, B7 School Bus, C6, C7 Topkick	7144X	88893907	N/A
2002-99	7.4L (454) (B&D), B7 School Bus, C6, C7 Topkick	7145X	12456231	N/A
1998	6.5L (395) (F) B7 School Bus, Diesel	7129X	12534772	N/A
1998-96	6.0L (366) (P) , 7.0L (427) (M) B7 School Bus (C5, C6 C7 Series)	7123X	12529192	10241634
1997	6.0L (366) (P) F6, 7 Series	7123X	12529192	10241634
1997	6.5L (395) (F) Diesel B7 School Bus, Exc. Hazard Warning Switch (C6, C7 Series)	7129X	12534772	N/A
1996-90	6.0L (366) (P) , 7.0L (427) (M) B7 & P6 School Bus (50, 60, 70 Series w/Screw on Hub)	7123X	12529192,12551474, 12512740, 10140677	10241634
1990-76	6.0L (366), 7.0L (427), 7.4L (454), 60 & 70 Series	7116X	10074182	14001939
1992-81	6.2L (379) C, J Diesel,	7117X	12514269, 15633465	14024206
1998-90	6.0L (366), 7.0L (427) 50, 60, 70 Series, School Bus	7123X	10140667	14001939
1984-73	5.7L (350), Series 40, 50, 60	7146X	6258551	330813
<b>Government Postal Vehicles</b>				
	1 Ton Dodge Mail Truck S6-P200 W170, 225	7086X	2930-983-4192	N/A
	Model 800, IHC Scout, Mail Truck	7312X	2930-073-3473	N/A
	Model CO/1600, IHC Scout, Mail Truck	7312X	2930-073-3473	N/A
<b>Hino Truck</b>				
	Tall Housing	7901X	N/A	2M28

Year/Make	Application/ Engine	BEP CO PART NUMBER	OEM Number	Casting Number
<b>International</b>	9200 , 2013-2007 Cummins ISX Engine	7097X	n/a	3683652
<b>International/ Harvester</b>				
	<b>Combine (6 Cyl.)</b>			
1970-68	SP-375 Windrower w/C175	7325X	303395R91, 601816C91	303394R1
1970-68	SP-315 w/D236	7325X	303395R91, 601816C91	303394R1
1970-68	SP-616, 622 Cotton Picker w/C301	7325X	303395R91, 601816C91	303394R1
1970-68	SP-205, 315w/C221	7325X	303395R91, 601816C91	303394R1
1970-66	SP-403 w/C263, C282, D282 (To Serial # 2195)	7325X	303395R91, 601816C91	303394R1
1970-66	SP-303 w/C221 (From Serial # 7278)	7325X	303395R91, 601816C91	303394R1
1970-62	SP-503 w/D301	7325X	303395R91, 601816C91	303394R1
	815, 915 w/D414, DT414 Diesel	7303X	673162C92, 673162C94	675806C2, 675806C3
	All w/D436, DT436 Diesel	7303X	673162C92, 673162C94	675806C2, 675806C3
	All w/D466, DT466	7303X	673162C92, 673162C94	675806C2, 675806C3
	<b>Tractor, Loaders &amp; Crawlers</b>			
	966, 1066, 1086, D414, DT414, D436, DT436, D466, DT466 Diesel	7303X	673162C92, 673162C94	675806C2, 675806C3
1980-69	100C LDR	7325X	601816C92	303394R1
1977-71	3600A w/C263	7325X	601816C92	303394R1
1977-62	D50, w/C301, H-50, A, B, C, w/D188, UD236, UD282, D301	7325X	601816C92	303394R1
1977-59	H-50, A, B, C, w/D188, UD236, UD282, D301	7325X	601816C92	303394R1
1975-72	9000 w/C291, C301	7325X	601816C92	303394R1
1975-1967	3800, 3850 w/C263	7325X	601816C92	303394R1
1974-68	H-60B w/C301	7325X	601816C92	303394R1
1974-62	TD9B & 150 LDR	7325X	601816C92	303394R1
1973-71	2500 Consall	7325X	601816C92	303394R1
1973-69	T & TD7	7325X	601816C92	303394R1
1971-65	2656 w/C263 & 3616 w/C221	7325X	601816C92	303394R1
1970-61	4 Cyl. Gas 504, 2504 Models	7325X	303395R91	303394R1
1970-58	6 Cyl. Gas 856, 2856 Models & 6 Cyl. Power Units UC221, 263, 291, UD188, 236, 282	7325X	303395R91	303394R1
1969-58	2706 w/C263, 291, 2756 w/C291, 2856 w/C301, H-25 PL w/D188, H-30 w/236, 282, H-40 w/V264-6A, TD62 w/263	7325X	601816C92	303394R1

1964-58	Farmall 460 Diesel	7325X	303395R91	303394R1
1961-58	Farmall 460, 560, 660 Gas Models	7325X	303395R91	303394R1
All	Models: H70, H86, 2606, 2706, 2756, 403, 460, 560, 606, 660, 706, 766, 806, 826, 856	7325X	601816C92	303394R1
<b>International/ Navistar</b>				
	<b>Compact Pickup - C900, D900</b>			
1965-64	4 Cyl. 2.5L (152) (w/Auto Fan)	7312X	861236R92	151203R1
	<b>Medium &amp; Heavy Duty Series (6 Cyl.)</b>			
	7.6L (466) Cab Over Models	7312X	680899C93	677137C1
	7.6L (466) Conventional Models, DT466 (B)	7301X	685155C92, 685155C94, 685155C95	677856C1, 677856C2
2007-2003	DT466 & 530E New Generation (7.6L)	7321X	1842664C92, 1841764C2, 1830607C4, 184664C92	1841765C1
2004-96	7.6L (466) Navistar Diesel 2554, 2574, 2654, 2674, 8100, 8200, 8300 Forward Control Series; 3600, 3700, 3800, 3900FC Bus Chassis Series	7313X	1817687C92, 1817687C96, 1830606C94	1821935C1, 1821935C3
2004-96	8.6L (530) Navistar Diesel 1400, 1452, 1600, Metro, 1652, 2554, 2654, 4500, 4600, 8200, 8300, Forward Control Series DT	7313X	1817687C94	1821935C1, 1821935C3
1997-93	5.9L (366) DT/DTA Diesel, 7.6L (466) DT/DTA Diesel 1600, 1652, 4500, 4700, 4800, 4900, 7100; Bus Chassis Series 3600, 3700, 3800, 3900CF	7310X	1815538C91, ZGA735327, 735445C91	677856C1, 677856C3
1995	7.6L (466) Navistar Diesel 2554, 2574, 2654, 2674, 8100, 8200, 8300 Forward Control Series (w/o Electronically Controlled Emissions)	7310X	1815538C91, ZGA735327, 735445C91	677856C1, 677856C3
1994-92	7.6L (466) Navistar Diesel (From 10/4/91) 2554, 2574, 2654, 2674, 8100, 8200, 8300	7310X	1815538C91, ZGA735327, 735445C91	677856C1, 677856C3
1992-1990	7.6L (466) Navistar Diesel To 10/4/91, 2554, 2574, 2654, 8100, 8200, 8300	7301X	685155C92, 685155C94, 685155C95	677856C1, 677856C2
1990	5.9L (360) FD1060 Cummins Diesel, 1452, 1624, 1654, 1723, 1724, 1753, 1754, 1824, 1853, 1854, 1924, 1925, 1954, 1955, 2125, 2155	7301X	685155C92, 685155C94, 685155C95	677856C1, 677856C2
1990	7.6L (466) Navistar Diesel 1452, 1624, 1654, 1723, 1724, 1753, 1754, 1823, 1824, 1853, 1854, 1924, 1925, 1954, 1955, 2125, 2155 Forward Control Series	7301X	685155C92, 685155C94, 685155C95	677856C1, 677856C2
All	DT466 7.6L (466) Cab over	7302X	680899C92	677137C1
1968-60	BC160 To 180 Series, D301 Diesel B	7325X	318119R92, 303395R92	169304R1, 303394R1

	<b>Medium &amp; Heavy Duty Series (8 Cyl.)</b>			
2000 & Up	7.3, T444E Bus/Truck Diesel	7322X	YC3Z-8501A	1831576C1
2004-94	7.3, T444E Bus/Truck Diesel	7315X	1823669C92	1822851C1, 1831676C91
1993-1991	7.3L (445) Navistar Diesel 1400 Metro, 1452, 1600, 1652 Forward Control Series	7305X	1805952C91, 1809374C91, 1809374C92, 1809374C93 , 1809374C94	44643C1
1993-1991	7.3L (445) Navistar Diesel 3600, 3700, 3800, 3900FC Bus Chassis Series, 4500, 4600	7305X	1805952C91, 1809374C91, 1809374C92, 1809374C93 , 1809374C94	44643C1
1990-71	6.6L (404), 6.9L (420), 7.3 (446) ,Cargostar, S Medium Series Gas & Diesel	7305X	1805952C91, 1809374C91, 1809374C92, 1809374C93 , 1809374C94	44643C1
1990-1979	9.0L (552) Diesel S Series Medium Duty	7308X	1700594C91, 1700594C92	489173C1
1990-1976	9.0L (552) Diesel Cargostar	7308X	1700594C91, 1700594C92	489173C1
1984-78	5.6L (V345) Gas 1452, 1624, 1652, 1654, 1723, 1724, 1753, 1754, 1823, 1824, 1853, 1924, 1925, 1954, 1955, 2125 Models	7312X		
	<b>Metro M Series Vans - M1100, M1200, MA1200, MS1210 (4 Cyl.)</b>			
1971	3.2L (196) (Models w/Fan Clutch)	7326X	357621C92	151203R1M
1971	3.2L (196) (Models w/o Fan Clutch)	7312X	463365C91	151203R1
	<b>Metro-Mite CM Series Vans - CM80, CM110 (4 Cyl.)</b>			
1965-63	2.5L (152) (w/Auto Fan)	7312X	861236R92	151203R1
	<b>Pickup - 100, 150, 200 Series (8 Cyl)</b>			
1975-74	5.0L (304), 5.6L (345), 6.4L (392) (Models w/Fan Clutch)	7326X	357621C92	151203R1M
1975-74	5.0L (304), 5.6L (345), 6.4L (392) (Models w/o Fan Clutch)	7312X	463365C91	151203R1
	<b>Pickup - 1000A,B,C,D; 1100A, B,C,D; 1200A,B,C,D; 1300A,B,C,D Series ( 8 Cyl.)</b>			
1970-66	4.4L (266), 5.0L (304) (Models w/Fan Clutch)	7326X	357621C92	151203R1M
1970-66	4.4L (266), 5.0L (304) (Models w/o Fan Clutch)	7312X	463365C91	151203R1
	<b>Pickup - 1010, 1110, 1210, 1310, Series (8 Cyl.)</b>			
1973-71	4.4L (266), 5.0L (304) (Models w/Fan Clutch)	7326X	357621C92	151203R1M
1973-71	4.4L (266), 5.0L (304) (Models w/o Fan Clutch)	7312X	463365C91	151203R1
	<b>Pickup - 900A, 908B, 908C Series</b>			

	<b>(8 Cyl.)</b>			
1968-66	4.4L (266), 5.0L (304) (Models w/Fan Clutch)	7326X	357621C92	151203R1M
1968-66	4.4L (266), 5.0L (304) (Models w/o Fan Clutch)	7312X	463365C91	151203R1
	<b>Pickup - B Series (8 Cyl.)</b>			
1960-59	4.4L (266)	7312X	463365C91	151203R1
	<b>Pickup - C Series (8 Cyl.)</b>			
1964-91	4.4L (266), 5.0L (304) (Models w/Fan Clutch)	7326X	357621C92	151203R1M
1964-61	4.4L (266), 5.0L (304) (Models w/o Fan Clutch)	7312X	463365C91	151203R1
	<b>Pickup - D1000, D1100, D1200 D1300 Series (8 Cyl.)</b>			
1965	4.4L (266), 5.0L (304) (Models w/Fan Clutch)	7326X	357621C92	151203R1M
1965	4.4L (266), 5.0L (304) (Models w/o Fan Clutch)	7312X	463365C91	151203R1
	<b>P44E</b>			
1996	DI-T444E Bus (7.3L)	7315X	182285102, 1823669C92	1822851C1, 1831676C91
	<b>Scout, Scout II Terra, Scout II Traveler (4 Cyl.)</b>			
1980-71	3.2L (196) (Models w/ Fan Clutch)	7326X	357621C92	151203R1M
1980-71	3.2L (196) (Models w/o Fan Clutch)	7312X	463365C91	151203R1
1977-66	3.2L (196) w/Auto Fan	7312X	463365C91	151203R1
1964-61	2.5L (152) w/Auto Fan	7312X	463365C91	151203R1
	<b>Scout, Scout II Terra, Scout II Traveler (8 Cyl.)</b>			
1980-71	5.0L (304), 5.6L (345) (Models w/Fan Clutch)	7326X	357621C92	151203R1M
1980-71	5.0L (304), 5.6L (345) (Models w/o Fan Clutch)	7312X	463365C91	151203R1
	<b>Travelall (8 Cyl.)</b>			
1975-61	4.4L (266), 5.5L (304), 5.6L (345), 6.4L (392) (Models w/o Fan Clutch)	7326X	357621C92	151203R1M
1975-61	4.4L (266), 5.5L (304), 5.6L (345), 6.4L (392) (Models w/o Fan Clutch)	7312X	463365C91	151203R1
1960-59	4.4L (266)	7312X	270918C92	151203R1



Year/Make	Application/ Engine	BEPKO PART NUMBER	OEM Number	Casting Number
<b>Isuzu Industrial</b>				
	<b>Medium Duty (4 Cyl.)</b>			
	C201PT (2.2) Diesel, Refrigeration Unit	7350X	11 4576	N/A
2002-2000		7353X	8-94391-670-5	N/A
	<b>NPR Truck (V8)</b>			
1993-92	5.7L (350)	7354	8-12524-498-0	10108457
<b>John Deere</b>				
	For Models: 5410, 5420, 5510, 5520	RE500737	N/A	N/A
<b>Kubota</b>	L235, L235DT, L235F, L275, L275DT, L355, L3350DT, L355SS, L4350	503180X	Cross Reference 15521-73033, 15521-73035, 15521-73039	
<b>Mack</b>				
	END 673, 675, 676, Short Shaft, No Pulley, w/Cast Iron Impeller	7201X	316GC184	360GB334
	Maxidyne ESI, ENDT 675, 676, Long Shaft, No Pulley, w/Cast Iron Impeller	7202X	316GC1184, 316GC1211A, B	360GB443A
	Thermodyne 673, 675, 711, Short Shaft, No Pulley w/Stamped Steel Impeller	7204X	316GC1184, 316GC1211A,	306GB334
	Maxidyne ESI, ENDT 675, 676, Long Shaft, No Pulley, w/Stamped Steel Impeller	7205X	316GC1211B	360GB443A
	END 673, 675, 676, w/Hub, Short Shaft w/Stamped Steel Impeller	7206X	316GC184N	360GB334
	Econodyne Charged Air E6, EM6, EMS 6, No Pulley, w/Stamped Steel Impeller	7208X	316GC1210A	360GB443A
	Econodyne Charged Air E6, EM6, EMS 6, w/3 Belt Pulley, w/Stamped Steel Impeller	7209X	316GC1210AX	360GB443A
	E6 Charged Air, w/3 Groove Pulley & Stamped Steel Impeller	7210X	316GC528CX	360GB443A
	Maxidyne ESI, ENDT 675, 676, Long Shaft, w/3 Groove Pulley, w/Stamped Steel Impeller	7211X	316GC523BX	360GB443A
	Maxidyne ESI, ENDT 675, 676, Long Shaft, w/4 Groove Pulley, w/Stamped Steel Impeller	7212X	316GC1184BP2X	360GB443A
	Maxidyne ENDT 675, 676, Long Shaft, w/Pulley	7214X	316GC1184BX	360GB443A
	675 ESI, ENDT, Long Shaft, w/Notched Pulley for Fan Clutch Applications	7215X	316GC1211AX	360GB443A
	Econodyne, E7, w/Flat Bottom Impeller, No Pulley	7216X	316GC1219, 316GC1219A	360GB443A
	E7 w/3 Belt Pulley, 7 1/4" O.D. & Metric Housing, w/Stamped Impeller (Short Shaft)	7217X	316GC548M2X	360GB251AM
	E7 w/3 Belt Pulley, 5 1/2" O.D. & Metric Housing, w/Stamped Impeller (Short Shaft)	7218X	316GC548MX	360GB251AM
	E6 w/3 Belt Pulley, 7 1/4" O.D. w/Stamped Impeller & B Housing (Short Shaft)	7219X	316GC549MX	360GB443A
	E7 Metric Housing & No Pulley, Short Shaft w/Stamped Impeller	7220X	316GC284	360GB251AM
	E6, 6 5/8" Pulley w/3 Belts and Flat Impeller & B Housing	7221X	316GC549M2X	360GB443B
	E7, Long Shaft w/3 Belt Long Pulley & Metric Housing (Long Shaft)	7222X	316GC4107MX	360GB251AM
	E7, 3 Belt Pulley w/6 5/8" O.D. & Metric Housing (Short Shaft)	7223X	316GC548M4X	360GB251AM

	E7, Long Shaft w/3 Belt Long Pulley & Metric Housing (Long Shaft)	7224X	316GC4108MX	360GB251AM
	E7, Metric Housing & No Pulley, Long Shaft	7225X	316GC63285A,B,C	360GB251AM
	E7 w/5 1/2" Multi Groove Pulley & 1 V Belt Pulley (Short Shaft)	7226X	316GC551M2X	360GB251AM
	E7 w/6 5/8" Multi Groove Pulley & 1 V Belt Pulley (Short Shaft)	7227X	316GC551MX	360GB251AM
	E7 w/6 1/4" Multi Groove Pulley & 1 V Belt Pulley (Short Shaft)	7228X	316GC551M3X	360GB52M
	E7 w/Long Multi Groove Pulley (Long Shaft)	7229X	316GC552M2X	360GB52M
	ACET w/5 1/4" Pulley	7230X	316GC3193	2379-12
	Granite CV13, eng 460 E Tech. Same as 7230X Except has Larger Pulley O.D.	7230LX	316GC3196	2379-12
2001/Up	E7 Serial number DM690S28406. Same as 7220X Except has Heavy Duty Bearing	7231X	316GC565M8X	360GB54M
	<b>Massey Ferguson, Massey-Harris</b>			
	<b>Combine (6 Cyl.)</b>			
1970-62	205, 300 Self-Propelled Gas	7086	1022115M91, 1039163M91, 3420050	2128284, 2863063, 2883663
	<b>Combine (8 Cyl.)</b>			
1969-64	510 Self-Propelled Gas	7090	1032473M91, 1035836M91, 3957981	38399175, 3859326
	<b>Tractor, Loaders &amp; Crawlers (3 Cyl.)</b>			
1970-65	MF-135, MF-150, MF-2135, Using Perkins Diesel Eng.	7088	735036M91	37711330B, 37711331
1964-60	MF-35, MF-50, MF203, MF-205, Using Perkins Diesel Eng.	7089	734527M91, 734932M91	37711330B, 37711331
	<b>Tractor, Loaders &amp; Crawlers (4 Cyl.)</b>			
1970-65	MF-135, MF-150, MF-2135, Gas Models	7091	830691M91	Z129K-402
1970-65	MF-180, Gas Models	7092	835615M91	Z129K-402
1964-58	MF-65 Gas Models w/Out Pulley	7092	835615M91	Z129K-402
1964-55	TO-35, F-40, H-140, F-35, MF-35, MF50 Gas Models	7091	830691M91, 8530514M91	Z129K-402
	<b>Mercedes Benz</b>			
	Model ATEGO (OM904)	7400X	940 200 04 01	N/A
	Model U3000, U5000, OM900, OM906	7401X	906 200 48 01, A906 200 1401, A906 200 2001, A906 200 4801, A906 200 1301	N/A
	<b>Perkins Engine Heavy Duty</b>			
	<b>3 Cyl.</b>			
1969-65	Engine AD3-153	7088	41312159, 41312487	37711330B, 37711331
1964-60	Engines 3A-152	7089	41312154	37711331
	<b>Thermo King</b>			
	Isuzu 2.2L C201, C201PT, Refrigeration Unit	7350X	11-4576	PH374
	2.2L Direct Injection, w/Auxiliary Port	7351X	11-5858, T-K4576	M1, M2
	2.2L Direct Injection, w/out Auxiliary Port	7352X	11-5858	M1, M2
	<b>White Truck &amp; White Auto Car</b>			
	<b>6 Cyl.</b>			

1968-61	Models using Cummins Diesel Straight Eng. NH-180, NH-195, NH-200, NH220 and White Auto Car (Right Hand Pump)	7077X	BM-50446, BM-76506	132423
1968-61	Models using Cummins Diesel Straight Eng. NH-250, NHE-225 (High Mounted Fan), NT-280, NT-300, NT-380 (Right Hand Pump)	7065X	AR-04283	196845
	<b>Volvo</b>			
	D12C, 12V	7500X	20431135, 20713787, 20734268	20713184, 8170307

OEM #  
994164

CASTING #  
F600K520

Repair Kit #  
Gasket Kit #

**7032X**  
**4 CYL FORKLIFT**

*Continental Engine F162  
With 2 Groove Pulley*

*No Picture  
Available at  
This time*

*R&R Available*

OEM #  
874617

CASTING #  
F600K519

Repair Kit #  
Gasket Kit #

**7033X**  
**4 CYL FORKLIFT**

*Continental Engine F163  
With 3 Groove Pulley*

*No Picture  
Available at  
This time*

*R&R Available*

OEM #  
994173

CASTING #  
F162K500

Repair Kit #  
Gasket Kit #

**7034X**  
**6 CYL FORKLIFT**

*Continental Engine  
F226, F227, F244, F245  
with 2Groove Pulley*

*No Picture  
Available at  
This time*

*R&R Available*

**NOTES:**

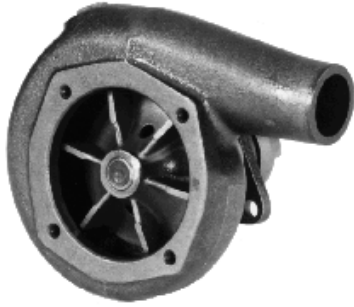

**7103X**  
**HD-5 DIESEL ENGINE**

*2 Cyl, Left Hand, 1955-1940*

**OEM #**  
5135595, 5149706  
23506723

**CASTING #**  
5135601, 5178317  
5135602, 5149707  
Repair Kit #2103RK  
Gasket Kit #2103G



**7103X**  
**HD-7 DIESEL ENGINE**

*3 Cyl, Left Hand 1955-1940*

**OEM #**  
5135595, 5149706  
23506723

**CASTING #**  
5135601, 5178317  
5135602, 5149707  
Repair Kit #2103RK  
Gasket Kit #2103G



**7104X**  
**HD-5 DIESEL ENGINE**

*2 Cyl, Right Hand, 1955-1940*

**OEM #**  
5135965, 5149707  
5178318, 23506735  
5135596

**CASTING #**  
5135602, 8920925  
Repair Kit #2104RK  
Gasket Kit #2104G



**7104X**  
**HD-7 DIESEL ENGINE**

*3 Cyl, Right Hand, 1955-1940*

**OEM #**  
5135965, 5149707  
5178318, 23506735  
5135596

**CASTING #**  
5135602, 8920925  
Repair Kit #2104RK  
Gasket Kit #2104G

# CATERPILLAR

OEM #  
9N6147X, 2W1225  
OR0781

CASTING #  
9N3076

**7001X**  
**3208 ENGINE**

*636 Cu. Inch Engine  
With no Pulley*



OEM #  
9N6147PX

CASTING #  
9N3076

**7002X**  
**3208 ENGINE**

*7001X with Bolt on Pulley  
(shown)*



OEM #  
2W1227X

CASTING #  
9N3076

**7004X**  
**3208 ENGINE**

*636 Cu. Inch Engine  
7001X with Threaded pulley for  
fan clutch*



OEM #  
9L7660, OR0644

CASTING #  
9L8323

**7005X**  
**1140 & 1160 ENGINE**

*Models: 1500, 1800  
3150 Engine*





**7006X**  
**3406 B&C ENGINE**

*893 Cu. Inch Engine  
Flat Gear with Curved Teeth*

**OEM #**  
7W7019, OR8217  
7C4957, 1OR0482,  
1354926

**CASTING #**  
9N5034



**7006EX**  
**3406E ENGINE**

*C15, C16  
Dome Gear & Curved Teeth*

**OEM #**  
OR8218E, 1OR0483  
OR4120, 613890,  
OR8330, OR8218

**CASTING #**  
9N5034-01, 135-4918  
102-5946, 100-7479



**7006EGX**  
**3406 E ENGINE**

*C15, C16  
With Straight Tooth Dome Gear*



**OEM #**  
OR9869, 1OR0484

**CASTING #**  
161-5718



**2006BP**  
**3406 & 3406E ENGINE**

*2006BP – Cast*

**OEM #**  
7C9222



**CATERPILLAR**



**7006X**  
**3406 CAT B&C,  
893 Cubic Inch  
Flat Gear  
Curved Teeth**



**7006EX**  
**3406E CAT  
Dome Gear  
Curved Teeth**



**7006EGX**  
**3406E CAT  
C15, C16  
Straight Teeth  
Dome Gear**



**2006G**

**3) O-Rings**

**2) O-Rings  
(Mounting)**

**1) Thermostat Seal**

**2)Gaskets  
Bonnett to Cover**

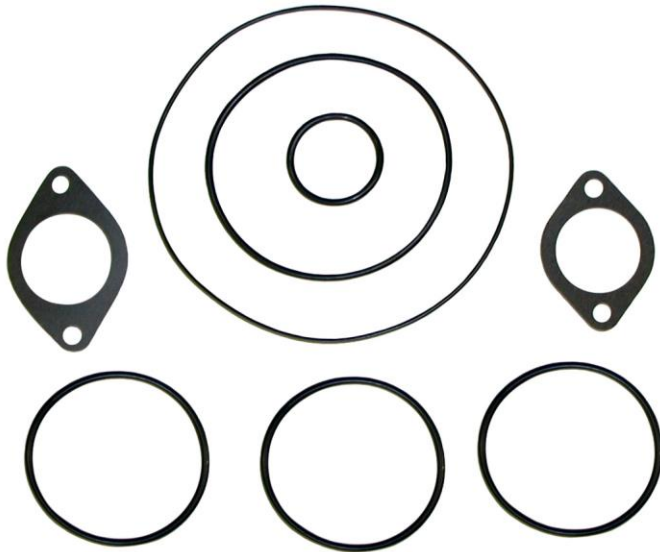

**GASKET KIT FOR Cat 3406**

**COMPLETE GASKET KIT  
FOR 3406 B, C, E**

**2006CG**

**Contains:  
2006G  
Plus**

**1) Gasket  
Aftercooler to Block**

**1) Gasket**

**1) Gasket  
Thermostat Housing Cover**

**1)Gasket  
Thermostat**

**1)Gasket  
Regulator**

**1) Gasket  
Thermostat Housing Cover**

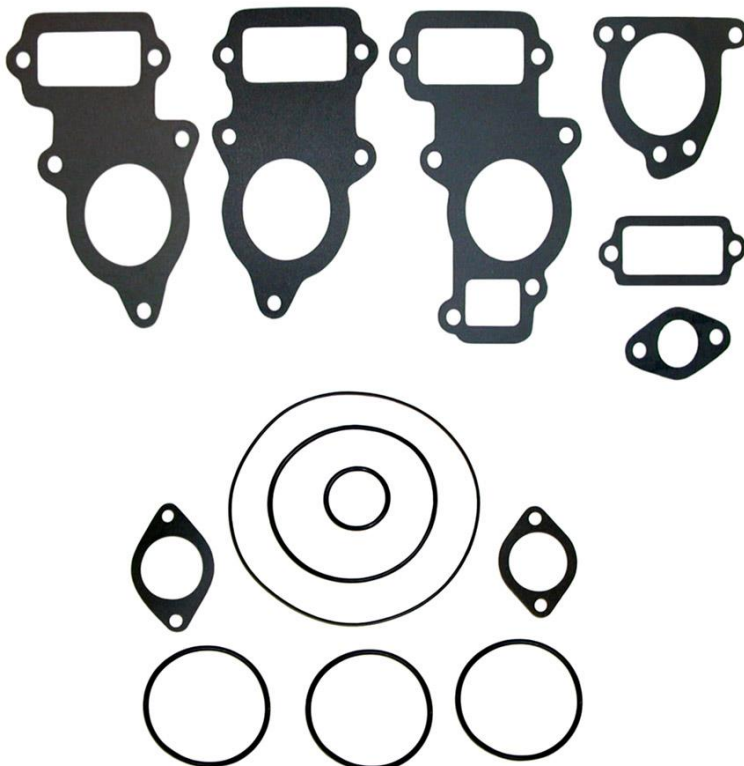

# CATERPILLAR



**7007X**  
**3306 Angled Teeth  
w/Off Set Holes  
and 3 1/8" Bearings**



**7007GX**  
**3306 Straight Teeth  
With Off Set Holes**



**7010X**  
**3304 w Angeled Teeth  
2 11/16" Bearings**

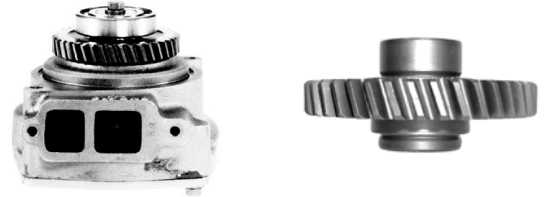

**7013X**  
**3306 Angled Teeth  
w/Off Set Holes  
and 2 3/8" Bearings**



**7014X**  
**3306 w/Solid Gear  
2 11/16" Bearings**



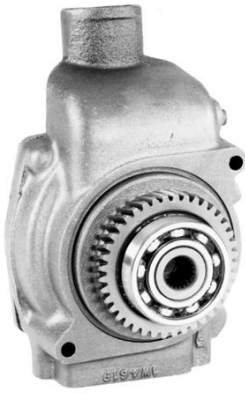

**7007X**  
**3306 ENGINE**

**OEM #**  
6N8413, OR1251

**CASTING #**  
7N196, 1W9619  
172-7829, 1543945



*Angled Teeth with offset holes  
& 3 1/8" bearing*



**7007GX**  
**3306 ENGINE**

**OEM #**  
OR8532, 4P9862  
OR9493, OR0997

**CASTING #**  
1W4619, 172-7827  
1543945, 7N196,  
1W9619, 172-7829



*Straight Teeth with offset holes*

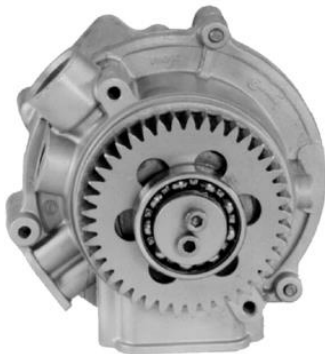

**7009X**  
**3176 ENGINE**

**OEM #**  
OR4117, 1025844,  
7E8554, 9Y4361,  
OR8766

**CASTING #**  
103-0745

*Aluminum Casting*

# CATERPILLAR

**OEM #**  
7N5909, 2P0662  
OR0797, 172776

**CASTING #**  
2P671

**7010X**  
3304, D330C, 3306  
ENGINE

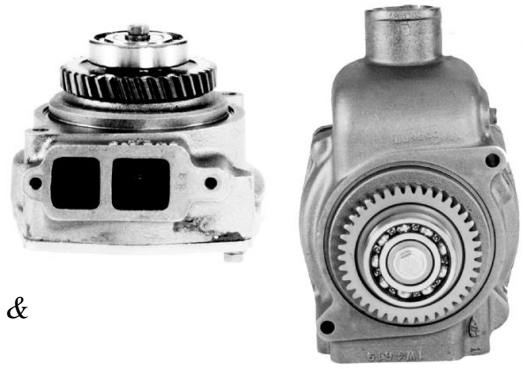

*With Straight Holes &  
2 11/16" Bearing*

**OEM #**  
1006944, OR0705, OR3007  
OR3709, OR8767, 4W0253,  
9Y4879

**CASTING #**  
105-4213, 105-4214  
176-6999

**7011X**  
3176B ENGINE



*C10, C12  
Cast Iron Housing*

**OEM #**  
OR1013, OR3007  
4W0253, 4P3683, 9Y4879

**CASTING #**  
4P3681

**7012X**  
3116 ENGINE

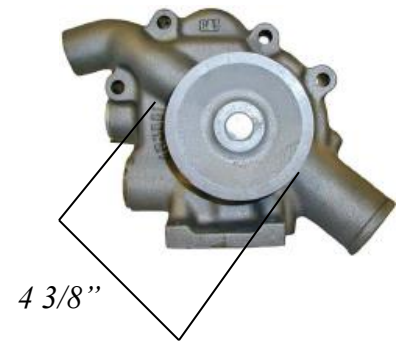

*With 4 3/8" Pulley*

**OEM #**  
OR1013, OR3007  
4W0253, 944879

**CASTING #**  
4P3681

**7012KX**  
3116/3126 ENGINE



*Same as 7012X  
with Fittings & 4 3/8" Pulley*



**7013X**  
**3306 ENGINE**

**OEM #**  
OR9497, OR1003

**CASTING #**  
7N196, 1W4619

*Similar to 7007X except  
Has 2 3/8" Bearing*



**7014X**  
**3306 ENGINE**

**OEM #**  
OR9785, OR1002

**CASTING #**  
7N196, 1W4619

*Similar to 7007X except  
Has Solid Gear &  
2 11/16" Bearing  
Angled Teeth  
(7014GX Straight Teeth)*



3 3/4"

**7015X**  
**3116/3126 ENGINE**

**OEM #**  
OR1013, 159-3141  
7W3780, 120-8402  
YP3682

**CASTING #**  
4W0249, 4P3681  
120-8402, 187-8957

*Same as 7012X but  
With 3 3/4" Pulley*

107-7701 Back Plate  
4W-0253 Back Plate  
7W3780 Pulley

**7012X**

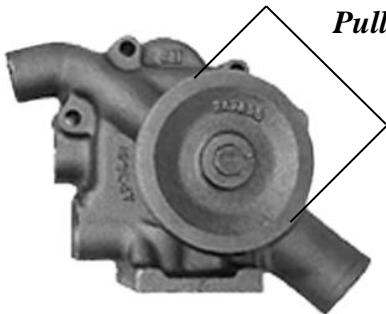

4 3/8"  
Pulley

**7015X**

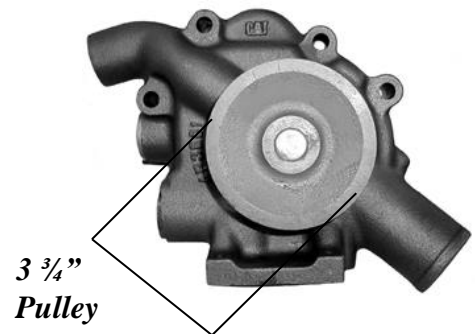

3 3/4"  
Pulley



# CATERPILLAR

**OEM #**  
10R5406

**CASTING #**  
20-6093-01  
203-6093-03

## **7016X** 3126 ENGINE

*C7, with Bolt on Pulley  
2003 & up  
Has Hub for a Multi Groove  
Pulley*



**OEM #**  
227-4299, 227-4301  
10R5407, 10R2790

**CASTING #**  
203-6093-01,  
203-6093-03  
246-3131

## **7016MX** 3126 ENGINE

*C7, with Press on Multi Groove  
Pulley  
Can use in place of 7016X*

*226-6051 Back Plate  
197-9581 Pulley*



**OEM #**  
10R2776, 10R3326,  
280-7374, 314-5155,  
10R8660

**CASTING #**  
224-3237, 246-3131,  
246-3137, 246-3132

## **7017X** 3406 ENGINE C15, C18

*Straight Teeth, Dome  
Gear, 8" Impeller  
opening  
(Looks like a  
7006EGX, but this unit  
has a larger housing)*



**OEM #**  
6N8413

**CASTING #**

## **7018X** 3306 ENGINE

*Similar to 7007X  
except  
Bottom holes are  
different*



OEM #

**7019X**  
**3116/3126**  
**ENGINE**

CASTING #  
128-5121

*3.75" Pulley, Threaded Ports*

# CATERPILLAR

OEM #  
1OR2129

CASTING #  
223-9145

**7020X**  
**C13 ACERT ENGINE**



OEM #  
OR2853, 2W8003

CASTING #  
1W6658, 6N8970

**7021X**  
**3306 ENGINE**



*40 LH Tooth Gear*

*Picture  
Not available  
At this time*

**7032X**  
**CONTINENTAL ENGINE**

OEM #  
994164

CASTING #  
F600K520

*Forklift, 4 Cyl  
F162, with 2 Groove Pulley*

**7033X**  
**CONTINENTAL ENGINE**

*Forklift, 4 Cyl  
F163, with 3 Groove Pulley*

OEM #  
874617

CASTING #  
994173

**7034X**  
**CONTINENTAL ENGINE**

*Forklift, 6 Cyl  
F226, F227, F244, F245  
With 2 Groove Pulley*

OEM #  
994173

CASTING #  
F162K500



# CHEVROLET

**OEM #**  
10074182

**CASTING #**  
14001939

## **7116X** **MEDIUM & HEAVY DUTY (8 CYL)**

**1990-1981**  
6.0L (366), 7.0L (427) School Bus, 60,  
70 Series w/Screw on Hub  
**1982-1979**  
7.4L (454), Series 60, 70

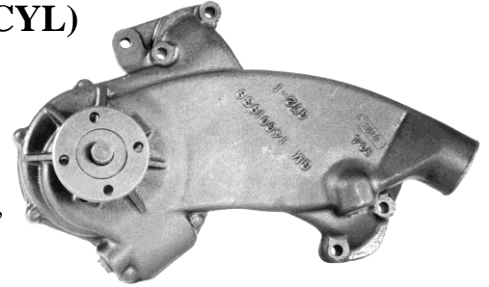

**OEM #**  
110140667, 12529192

**CASTING #**  
10241634, 14001939

## **7123X** **MEDIUM & HEAVY DUTY (8 CYL)**

**1998-1996**  
6.0L (366), 7.0L (427), B7 School Bus,  
C5, C6, C7 Series w/screw on Hub  
**1997**  
6.0L (366), F6, 7 Series w/Screw on Hub  
**1995-1990**  
6.0L (366), 7.0L (427) P6 School Bus,  
50, 60, 70 Series w/Screw on Hub



**OEM #**  
12534772, 5744662

**CASTING #**  
12557071

Gasket Kit # 2129G

## **7129X** **MEDIUM & HEAVY DUTY (8 CYL)**

**1998**  
6.5L (395), B7 School Bus  
**1997**  
6.5L (395), B7 School Bus, Exc  
Hazard Warning Switch



# CHEVROLET

## 7148X

### MEDIUM & HEAVY DUTY (6 CYL)

OEM #

10112691, 474056  
357262

*No Picture  
Available  
At this time*

CASTING #

465802,  
352199 2<sup>nd</sup> Design

1989-1988

4.8L (292, P4 Series

1987-1981

4.8L (292), Series 50, 60

1984-1983

4.8L (292), Series 50, 60, School Bus

1980-1974

4.8L (292), Series 50, 60, 2ndDesign

*R&R  
Available*

## 7144X

### MEDIUM & HEAVY DUTY (8 CYL)

OEM #

88893907, 1255863

*No Picture  
Available  
At this time*

CASTING #

12558870

2004-2003

8.1L Kodiak C4500, C5500, C6500,  
C7500, C8500

2002-2001

8.1L C6, C7, Kodiak, B7 School Bus

*R&R  
Available*

## 7145X

### MEDIUM & HEAVY DUTY (8 CYL)

OEM #

12456328

*No Picture  
Available  
At this time*

CASTING #

2000-1999

7.4L, B7 School Bus, Kodiak C6,  
C7, with Threaded Hub & Bypass  
Tube

*R&R  
Available*

# CHEVROLET

**7146X**

**MEDIUM & HEAVY DUTY (8 CYL)**

**OEM #**

10048921, 6258551

*No Picture  
Available  
At this time*

**CASTING #**

330813, 330813P

*R&R  
Available*

Repair Kit # n/a  
Gasket Kit # n/a

*1990-1973*

*5.7L (350) Series 40, 50, 60*

# CLARK

**OEM #**

865774  
F162K-3653

**7035X**  
**4 CYL ENGINE**

*No Picture  
Available  
At this time*

**CASTING #**

F400K-422

*R&R  
Available*

*Continental Series F162 Engine Pump  
w/Back Plate & 2 Groove Pulley*

**OEM #**

865707  
Y400K-3612

**7036X**  
**4 CYL ENGINE**

*No Picture  
Available  
At this time*

**CASTING #**

Y400K-410

*R&R  
Available*

*Continental Series Y400 Engine Pump  
w/Back Plate & 2 Groove Pulley*

**7035X**

**4 CYL ENGINE**

**OEM #**

F162K-3653

*Picture not  
Available  
At this time*

**CASTING #**

F400K-422

*R&R  
Available*

*Series F162 Pump Using F400K-422  
Body, w/Back Plate &  
2Groove Pulley HD206K-305*

**7036X**

**4 CYL ENGINE**

**OEM #**

F162K-3612

*Picture not  
Available  
At this time*

**CASTING #**

F400K-410

*R&R  
Available*

*Series Y400 Pump Using Y400K-410  
Body, w/Back Plate &  
2Groove Pulley Y91K-336*

OEM #  
3022920

**7040X**  
**KT/KTA 1150 ENGINE**  
**1989-1968**

CASTING #  
206964, 206864

*KT/KTA 1150*



OEM #  
3051368, AR10961

**7041X**  
**NH/NT 855 ENGINE**

CASTING #  
3004745

*4 11/16" Multi Groove Pulley  
4 1/2" Impeller*



OEM #  
3051378

**7042X**  
**BIG CAM ENGINE**

CASTING #  
219040

*4 11/16" Multi Groove Pulley &  
4 1/2" Impeller With 7 Hole Casting  
Can Use 7052X*



OEM #  
A34079-A05, AR61788

**7043X**  
**DINA 504 ENGINE**  
**6 & 8 Cylinders**  
**1989-68a**

CASTING #  
555260, 3804024

*Dina with front engine  
155 6 Cyl & 210 8Cyl  
2 Groove Pulley  
(7070X has 3 groove pulley)*



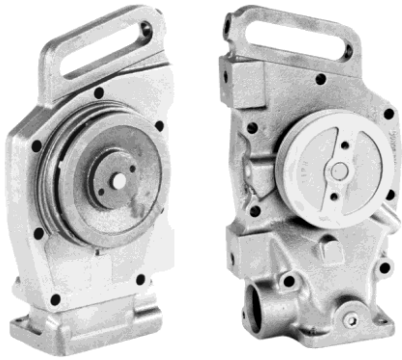

**7044X**  
**BIG CAM ENGINE**  
**1989-68**

OEM #  
3007290

CASTING #  
210238

*4 11/16" Multi Groove Pulley  
5 1/8" Impeller on Reverse Side*

*Picture not  
Available  
At this time*

**7045X**  
**DINA ENGINE**  
**1989-68**

OEM #  
AR61789, 14079-D105  
34079-B105, 377411

CASTING #  
555260

*Dina with Rear Engine  
155 6Cyl & 210 8Cyl*



**7047X**  
**220, NHT, NHRS**  
**ENGINE**

OEM #  
BM50345, BM50356

CASTING #  
165135, 115498

*With 5 1/8" Bore, 2 5/8" Shaft*

**7047SX**  
**220 ENGINE**

OEM #  
n/a

CASTING #  
n/a

*Smaller Top Bearing with  
Snap Ring in 2<sup>nd</sup> Slot*

# CUMMINS

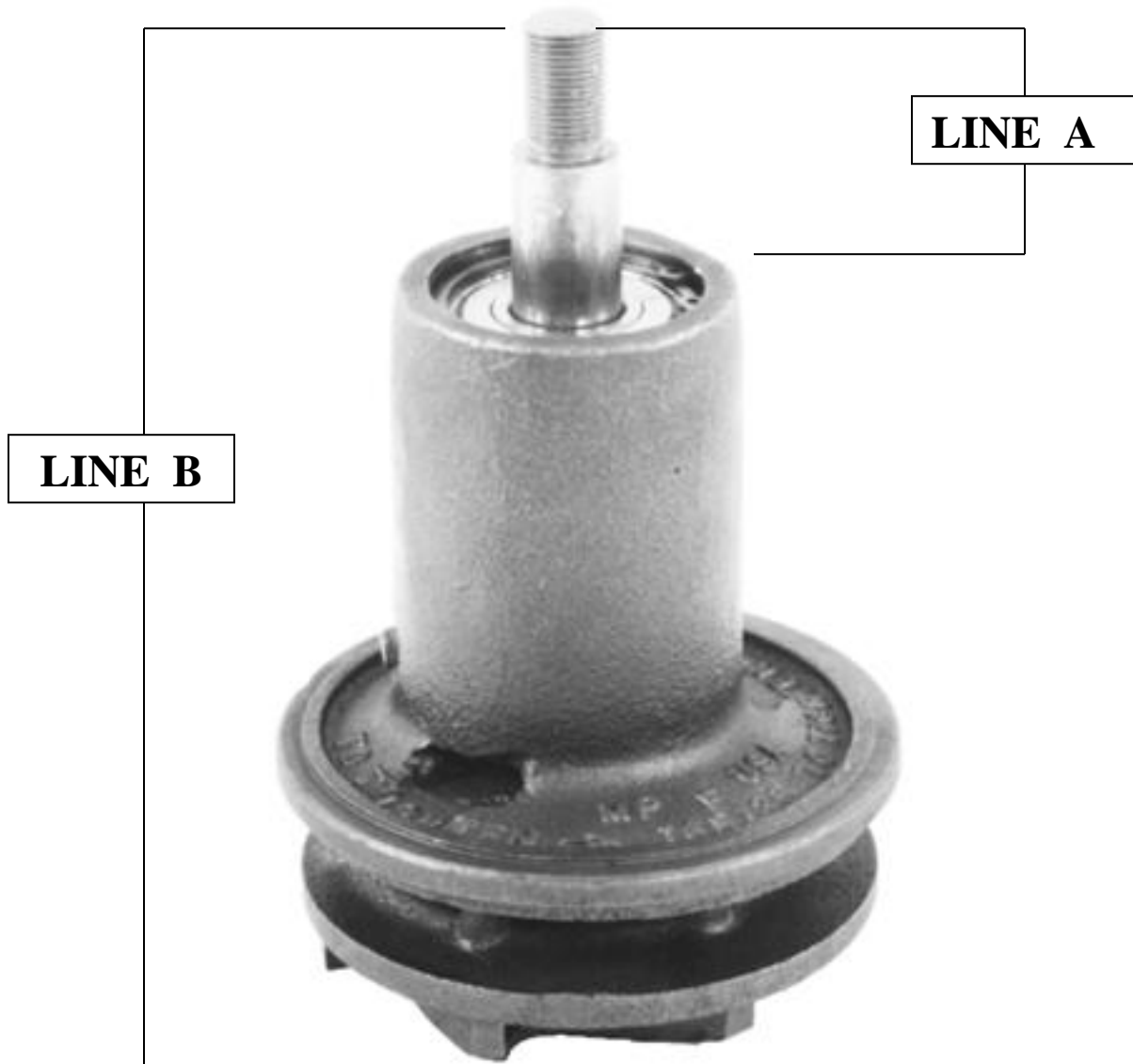

PART #	LINE A	LINE B	PULLEY SIZE
7047X	2 5/8" 220 NHT, NHRS	9 1/4" 5 1/8" Bore	5 3/8"
7047SX	2 5/8" Smaller Top Bearing	9 1/4" w/snap ring in 2 <sup>nd</sup> slot	5 3/8"
7048X	2 7/8" 220 NRT, NROT	9 7/8" 5 1/8" Bore	5 3/8"
7054X	2 5/8" NT & NTC 250	9 1/4" 5 1/2" Bore	5 3/4"
7055X	2 7/8" NT & NTC 250	9 7/8" 5 1/2" Bore	5 3/4"





**7048X**  
**220, NRT, NROT ENGINE**

**OEM #**  
BM71040

**CASTING #**  
165135

*With 5 1/8" Bore  
2 7/8" Shaft*



**7049X**  
**FFC ENGINE**

**OEM #**  
3024671

**CASTING #**  
210238

*Small Cam  
4 11/16" Multi Groove Pulley  
4" Impeller, 7 Hole Mount*

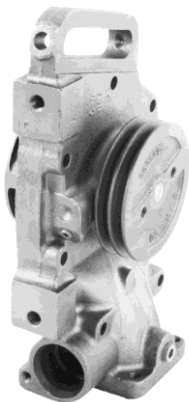

**7050X**  
**SMALL CAM ENGINE**

**OEM #**  
3045161

**CASTING #**  
218274

*Small Cam, 6 Hole Mount  
2 Groove Pulley w/ 4 1/2" Impeller*

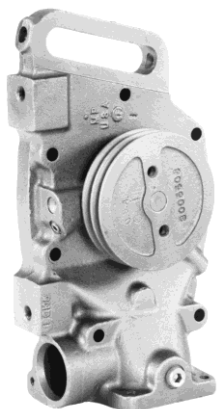

**7051X**  
**FFC ENGINE**

**OEM #**  
3000886, 3801784  
AR45090, AR8855

**CASTING #**  
210238, 219040

*NTC270-CT, NT855-C280, NTC290,  
NTC290-R, NTC855-C310, NTC350,  
NTA855-C360  
Double Groove Pulley, 5 1/8" Impeller*

# CUMMINS

**OEM #**

n/a

**7051KX**  
**FFC ENGINE**

**CASTING #**

n/a

*7051X with Idler Pulley*



**OEM #**  
3022474, 3801788  
AR45184

**7052X**  
**BIG CAM I & II ENGINE**

**CASTING #**

218274

*NTC290, NTC350, NTC400, Formula 290,  
350, Suitcase Pump w/4 11/16" Multi  
Groove Pulley & 4 1/2" Impeller, Venter*



**OEM #**

n/a

**7052KX**  
**BIG CAM I & II ENGINE**

**CASTING #**

n/a

*7052X With Multi Groove Idler Pulley*



**OEM #**  
AR4284

**7053X**  
**PANCAKE TYPE ENGINE**

**CASTING #**

196845

*5 1/2" Bore, NH, NT & NTC Non FCC,  
NH230, NH250, NHC270, NHE225 Diesel,  
NT280, NT300, NT310, NT335,  
NT380, NTA380, NTC335, NTC350  
NTC380, Non FFC, w/ 2 Belt Pulley*

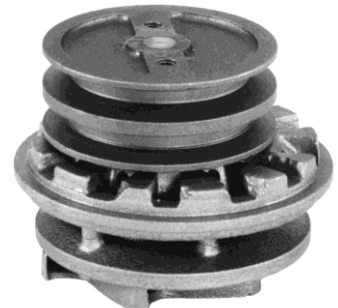



**7054X**  
**NT & NTC 250  
ENGINE**

**OEM #**  
AR4547

**CASTING #**  
196830

*5 1/2" Bore & 9 1/4" Shaft*

**OEM #**  
AR4548

**7055X**  
**NT & NTC 250 ENGINE**

**CASTING #**  
196830

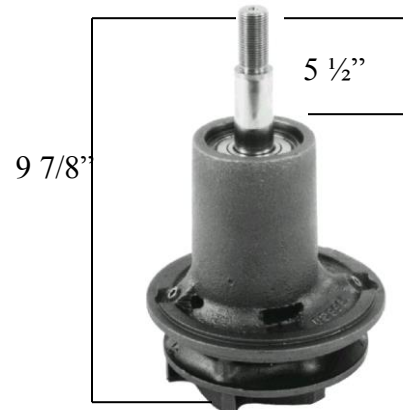

*5 1/2" Bore & 9 7/8" Shaft*



**7056X**  
**VT903 ENGINE**

**OEM #**  
AR5664

**CASTING #**  
196930

*With 3 Belt Pulley*

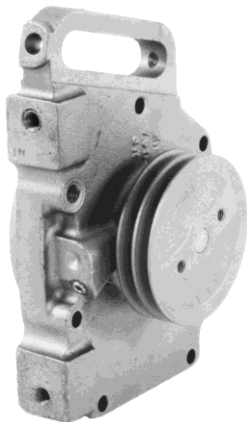

**7057X**  
**NTC FORMULA 250 ENGINE**

**OEM #**  
3022471, AR45073

**CASTING #**  
3002520

*Short Suitcase  
2 Groove Pulley w/4" Impeller*

# CUMMINS

OEM #  
AR8851, 3064920

CASTING #  
208118

**7058X**  
**FFC SMALL CAM ENGINE**

*2 Groove Idler Pulley*



OEM #  
AR45189, 3064919

CASTING #  
215397

**7059X**  
**BIG CAM I & II ENGINE**

*Multi Groove Idler Pulley*



OEM #  
3803138, 3052836  
3062928, 3803030

CASTING #  
3062899

**7060X**  
**NTC ENGINE**

*NTC300, 315, 350, 365, 400  
With Multi Groove Pulley  
Stamped Impeller*



OEM #  
3004923

CASTING #  
218274

**7061X**  
**BIG CAM III ENGINE**

*NTC300, 350, 400: Formula 300, 350, 400,  
475(Suitcase Pump)  
4 11/16" Multi Groove Pulley &  
4 " Impeller*

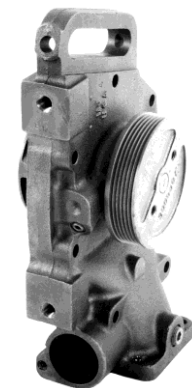



**7062X**  
**ENGINE**

**OEM #**  
3027882

**CASTING #**  
3002520

*4 11/16" Multi Groove Pulley  
4 1/2" Impeller*



**7063X**  
**B SERIES ENGINE**

**OEM #**  
3903749, 3913432  
3286287, 3802358  
3802970, 3802971

**CASTING #**  
3913132

*3.9L 4Cyl, 5.9L 6Cyl  
New Style Pulley without Lip  
Smooth Surface*

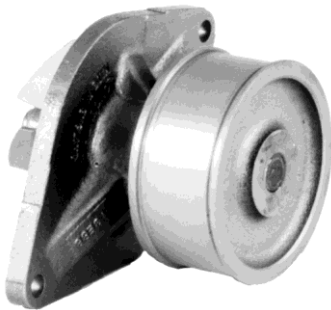

**7063AX**  
**B SERIES ENGINE**

**OEM #**  
3003731, 3802004

**CASTING #**  
3913132

*3.9L 4Cyl, 5.9L 6Cyl  
Old Style Pulley (Smooth) with  
Lip*

*Note Mounting Difference  
between 7063AX & 7063X*

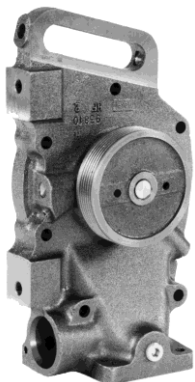

**7064X**  
**BIG CAM IV ENGINE**

**OEM #**  
3801708, 3045943RX

**CASTING #**  
3045163  
UK = 93810

*300, 350, 400, Fleet 300, NTC Formula  
300, 350, 400, 4 1/2" Impeller  
4 1/4" Multi Groove Pulley*

OEM #

**7064KX**  
**BIG CAM IV ENGINE**



CASTING #

*7064X Idler Pulley*

OEM #  
AR4283, AR4284

**7065X**  
**855 Diesel**

CASTING #  
196845

*With 5 1/2" Bore*  
*NH, NT & NTC Non FCC, NH230, NH230,*  
*NH250, NHC270, NHE225 Diesel, NT280, NT300,*  
*NT310, NT335, NT380, NTA380, NTC335,*  
*NTC350, NTC380, Mon FCC w/out pulley*



OEM #  
3801840, 3803402

**7066X**  
**L10 & M11 SERIES ENGINE**

CASTING #  
3035157, 3039182

*LTA10, 240, 270, 300*  
*4 Hole Mount up to 1991*



OEM #  
3034969, 3062602

**7067X**  
**L10 & M11 SERIES ENGINE**

CASTING #  
3060884

*Multi Groove Idler Pulley*



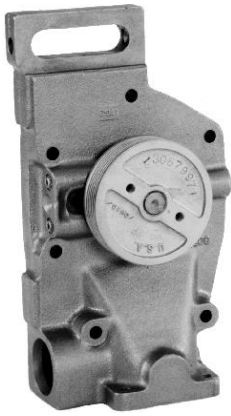

**7068X**  
**N14 ENGINE**

**OEM #**  
3803605, 3803361

**CASTING #**  
3069644, 3076523

*310, 330, 370, 410,  
With Multi Groove Pulley  
6 Hole Mount*



**7069X**  
**BIG CAM IV ENGINE**

**OEM #**  
2062931, 3801234  
3062930

**CASTING #**  
3064201R

*Multi Groove Pulley*

**OEM #**  
AR61116

**CASTING #**  
553928

**7070X**  
**V, VT555, V8 ENGINE**



**OEM #**  
3065000

**CASTING #**

**7071X**  
**ENGINE**



*Smooth Idler Pulley*



# CUMMINS

OEM #  
3803403, 4972843

CASTING #  
3882615, 4926554

## 7072X L10 & M11 ENGINE

*L-10E-MTA, 11-330E  
With 3 Hole Mount, Long Shaft  
1991 and after  
Shaft = 2 ½"*



OEM #  
3803403

CASTING #  
3882615

## 7072SKX L10 & M11 ENGINE

*7072X with Seal Kit*

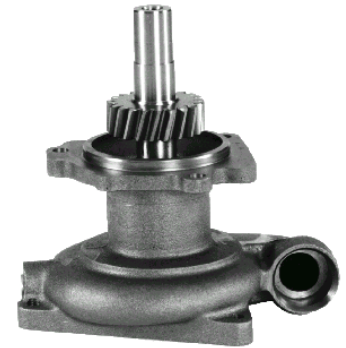

OEM #  
4955708NX

CASTING #  
3882615

## 7072SSX L10 & M11 ENGINE

*7072X with Short Shaft  
Shaft = 1"*



OEM #  
4089389, 4955708

CASTING #  
4926554, 3102501

## 7072SLX TSM & M11 ENGINE

*7072X with Short Shaft  
Housing is larger than 7072SSX  
and has extra port*





**OEM #**  
3066330

**CASTING #**  
n/a

**7073X**  
**N14 ENGINE**



*Multi Groove Idler Pulley*

**7074X**  
**88 NT ENGINE**

**OEM #**  
3062930

**CASTING #**  
n/a

*Idler Pulley with Bracket*

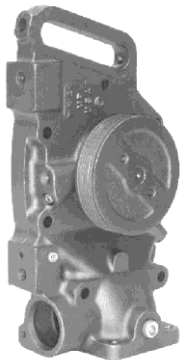

**7075X**  
**BIG CAM ENGINE**

**OEM #**  
3027174,3045943

**CASTING #**  
3045163

*4 11/16" Multi Groove Pulley  
w/Vent Hole & 4 1/2" Impeller*



**7076X**  
**C SERIES ENGINE**

**OEM #**  
3802081, 3804883RX  
F3HZ8501B, 3905357,  
3286293

**CASTING #**  
3903357

*See Attached Paperwork  
Ford Application has Flat Pulley  
Cummins App has Dome Pulley  
This Unit is a  
Ford Application Only*

# CUMMINS



## 7076LX ENGINE

OEM #  
3800976, 3800974

CASTING #  
3903357

*Same as 7076X  
Except  
It has a Dome Shaped Pulley*

## 7076X *Flat pulley*



Ford Application  
*(Old Style)*



Cummins Application

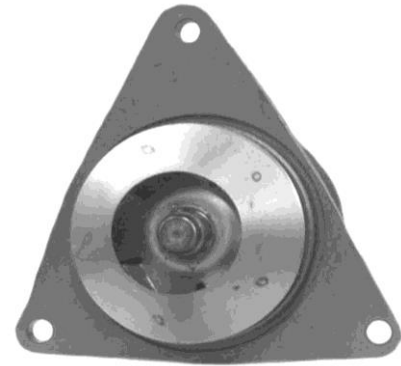

## 7076LX

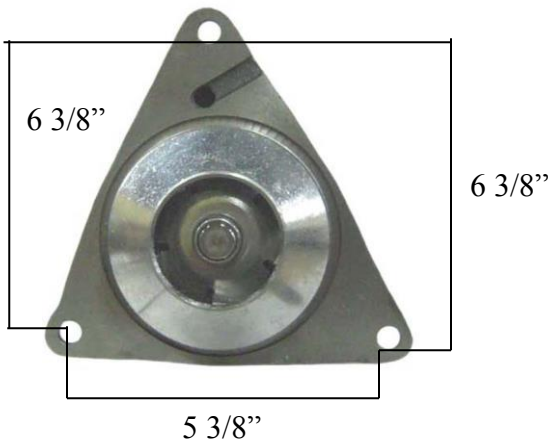

*Newer Version of 7076X*

*Groove in Casting*

*Dome shaped Pulley (shown)*

*Will not work for Ford*

*Will work for Cummins*

# CUMMINS

## 7082X

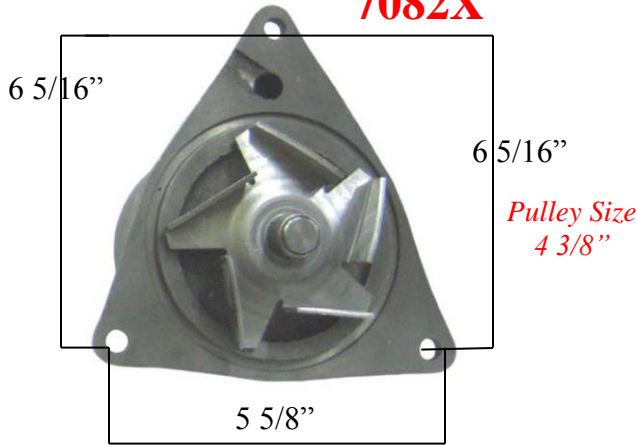

## 7082AX



Same measurements as 7082X  
***except*** pulley is smaller  
***Pulley Size = 3 13/16"***

***ISC/ISL SERIES...Larger Plate than 7076X...Longer Nose...Groove in Casting...With or W/O Dome Shaped Pulley***



## **7077X** NH 220 ENGINE

**OEM #**  
BM50446, BM76506

**CASTING #**  
132423

*H, HF, HR, HRS, NFT, NRT, NRTO,  
NH220, NHE180, NHE195, NHE220,  
NHS, NHRS (w/High Mounted Fan)  
Without pulley (Right hand mounted Pump)*



## **7077PX** NH 220 ENGINE

**OEM #**  
BM54327

**CASTING #**  
132423

*7077X Unit with Pulley added  
H, HF, HR, HRS, NFT, NRT, NRTO,  
NH220, NHE180, NHE195, NHE220,  
NHS, NHRS (w/High Mounted Fan)  
Without pulley (Right hand mounted Pump)*

# CUMMINS



**7078X**  
V, VT, VTA ENGINE  
1989-68

*1710 Engine*

OEM #  
AR-11229RX

CASTING #  
181094H



**7079X**  
KT, KTA ENGINE

*2300 Engine*

OEM #  
AR-11229RX

CASTING #  
181094H  
3030489, 3030490

OEM #  
AR51360

CASTING #  
196830, 202963

**7080X**  
855 NHC 250 ENGINE

*5 1/2" Bore  
Push on pulley  
Military Application*



OEM #  
3804826

CASTING #  
3084024

**7081X**  
N14 VOLVO ENGINE

*Volvo*



**OEM #**

3286293, 3973114  
3804927, 3940052  
4089647(NX), 4089952  
3964791

**CASTING #**

2370-10C, 2857-10C

**7082X**  
**ISC, ISL SERIES ENGINE**

*ISC & ISL Series  
Similar to 7076 except has larger  
casting at mount with a Larger  
Impeller  
Pulley 4 3/8"*



**OEM #**

**CASTING #**

2857-10C

**7082AX**  
**ISC, ISL SERIES ENGINE**

*ISC & ISL Series  
Similar to 7076 except has larger  
casting at mount with a Larger  
Impeller  
Slightly Smaller Pulley 3 13/16"*



**OEM #**

4025097, 4089158  
4089908, 4089910,  
3800495, 4026702,

**CASTING #**

2201-10MJ

Gasket Kit #2083G

**7083X**  
**ISX 600 SERIES ENGINE**

*10 Groove Pulley (4059254)*

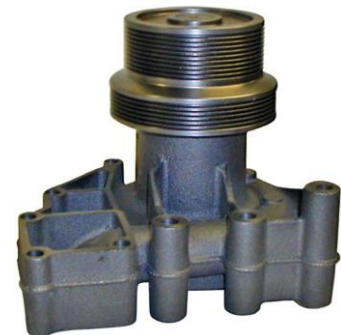

# CUMMINS

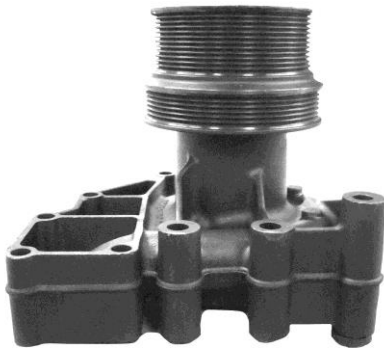

## **7084X** ENGINE

**OEM #**  
3800495

**CASTING #**  
2201-10MJ

*Same as 7083X except has  
12 Groove Pulley on Top Step*

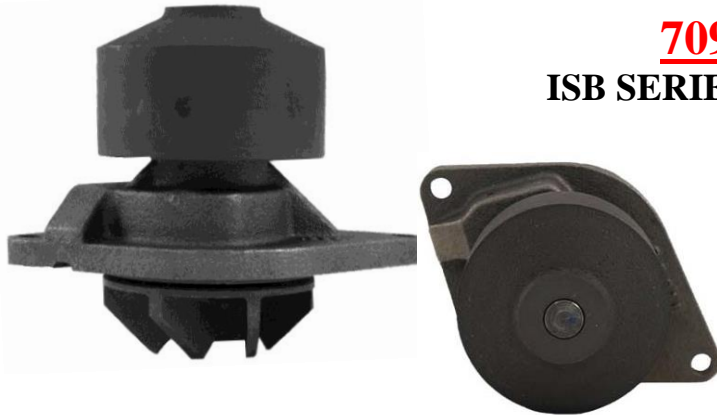

## **7098X** ISB SERIES ENGINE

**OEM #**  
2881804, 4955359,  
68003402AA,  
3959229

**CASTING #**  
451031/02

*Cummins, Dodge 6.7  
2012-2007  
Pulley is smaller than pulley on 7099X*



## **7099X** ISB SERIES ENGINE

**OEM #**

**CASTING #**  
2894-10C

*Cummins, Dodge 6.7  
2007-2004  
Pulley is bigger than pulley on 7098X*

**OEM #**

5144685,23506003  
5144687, 5178658

**CASTING #**

5144688, 5144689

**7101X**  
**53 SERIES ENGINE**

*Left Hand*

**OEM #**

23506007

**CASTING #**

5144687, 5178658,  
23506007

**7102X**  
**53 SERIES ENGINE**

*Right Hand*

**OEM #**

5135595, 5149706  
23506723

**CASTING #**

5135601, 5178317  
5135602, 5149707

**7103X**  
**3,4,6 Cyl, IN-LINE ENGINE**

*(ExcTurbo)*  
*Left Hand Pump*

**OEM #**

51355965, 5149707  
5178318, 23506735

**CASTING #**

5178318, 8920925

**7104X**  
**3, 4, 6 Cyl, IN LINE ENGINE**

*Right Hand*  
*(Exc Turbo)*





# DETROIT

OEM #  
5135595

CASTING #  
5135601

**7103X**  
**3, 4, 6 CYL IN LINE ENGINE**

*See Applications Below*



**7103X**

1979

Titan 90 Series w/54 BBC 6V-92T, 6V-92TT,  
8V-92T, Diesel Engine, Left Hand Mount

1978-1973

Series 50, 60, 65 w/6-71 Diesel Engine  
Left Hand Mount

**7104X**

1979

Titan 90 Series w/54 BBC 6-71 Diesel Engine  
Right Hand Mount

1978-1973

Series 50, 60, 65 w/6-71 Diesel Engine, Right  
Hand Mount

1977-1970

Series 90 w/6-71 Diesel Engine

OEM #  
5135596, 5178318

CASTING #  
5135602

**7104X**  
**3, 4, 6 CYL IN LINE ENGINE**

*See Applications Above*





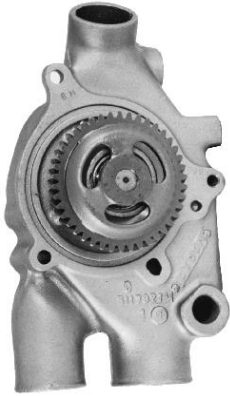

**7105X**  
**V6 & V8 ENGINE**  
**Non Turbo**

*Standing, 2 Outlets pointing  
Straight down, Standard Capacity  
w/Bolt on Back Cover*

*Use 7107X for High Capacity  
Use 7118X if Reverse Gear*

**OEM #**  
5149328, 23501938

**CASTING #**  
5106180  
5136455, 5106160,  
5117921

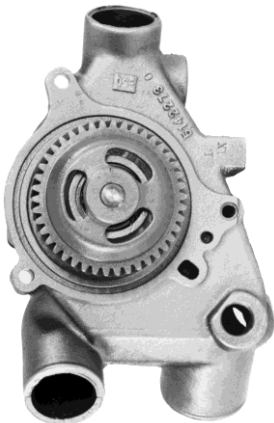

**7106X**  
**V6 & V8 ENGINE**

*Running, 2 Outlets @45 deg angles in  
opposite directions  
Standard Capacity, Non Turbo  
With bolt on back cover*

**OEM #**  
5149329, 23501939

**CASTING #**  
5142273

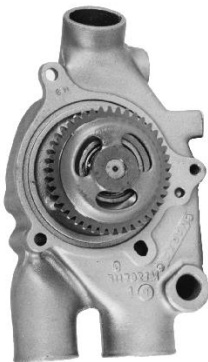

**7107X**  
**V6 & V8 ENGINE**

*Standing w/2 outlets pointing straight  
down, High Capacity  
With bolt on back cover  
(Standard Gear)*

*Use 7118X if Reverse Gear*

**OEM #**  
5149326, 23506790

**CASTING #**  
5135455, 5106180  
5106160

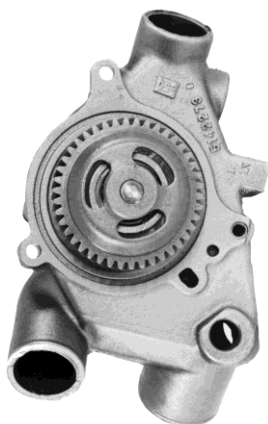

**7108X**  
**V8 ENGINE**

*Running, 2 Outlets @45 deg  
angles in opposite directions  
High Capacity,  
Bolt on Back Cover*

*Use 7115X if Reverse Gear*

**OEM #**  
5149327, 23506791

**CASTING #**  
5142273

# DETROIT

**OEM #**

8922336, 8921105  
23506602

**CASTING #**

8921100, 8922325

**7109X**  
**92 SERIES**  
**V6 & V8 ENGINE**

*Walking, w/1 Outlet pointing down  
And 1)outlet @ a 45 deg angle  
With Snap Ring Back Cover,*

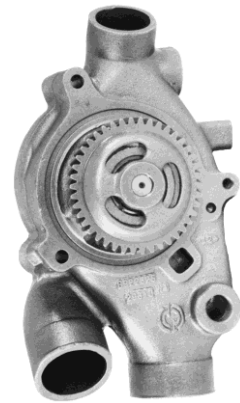

**OEM #**

8922335, 8921104  
23506623

**CASTING #**

8921099, 5101162

**7110X**  
**92 SERIES**  
**V6 & V8 ENGINE**

*Running, 2 Outlets @ 45 deg angle  
In opposite directions,  
with Snap ring back cove*



**OEM #**

5149320, 23506778

**CASTING #**

5101802

**7111X**  
**71 SERIES**  
**V6 & V8 ENGINE**

*Walking, w/1 Outlet pointing down &  
1)outlet @45 deg angle  
With Bolt on Back Cover  
92 Series*

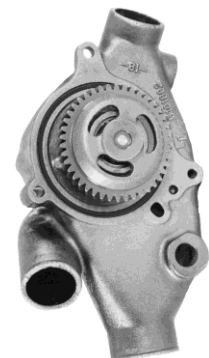

**OEM #**

5149321, 23506763

**CASTING #**

5145089

**7112X**  
**71 SERIES**  
**V12 ENGINE**

*Standing, w/Bolt on Back Cover  
And Heater Provision. High Capacity*

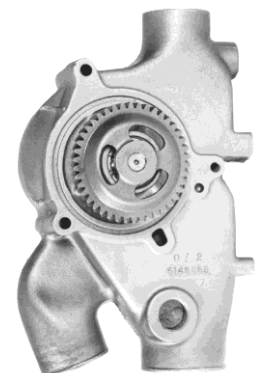



**7113X**  
**71 SERIES IN LINE**

**OEM #**  
5149710, 23506204,  
23506704

**CASTING #**  
5182069

*High Capacity, Left Hand*

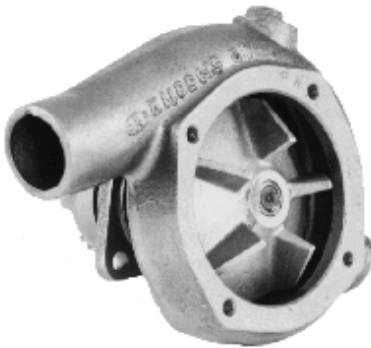

**7114X**  
**71 SERIES IN LINE**

**OEM #**  
5149708, 23506711

**CASTING #**  
5182070

*High Capacity,  
Right Hand*

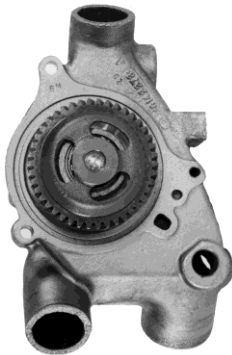

**7115X**  
**71 SERIES V8**

**OEM #**  
5149381, 23506698

**CASTING #**  
5142273

*Running, w/2Outlets @45 deg angles  
in opposite directions, High Capacity  
Reverse Gear, Bolt on Back Cover*

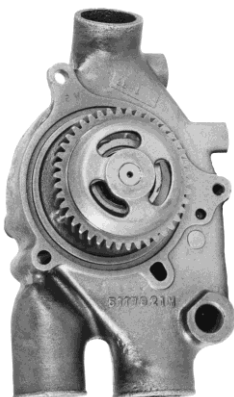

**7118X**  
**71 SERIES V8**

**OEM #**  
5149382, 23506670

**CASTING #**  
5135455

*Standing, 2 Outlets pointing straight  
down, High Capacity, Turbo  
RH Gear & Bolt on Back Cover (Use  
7107X for Standard Gear)*



# DETROIT

**OEM #**  
8922302

**7119X**  
**8.2 L ENGINE**

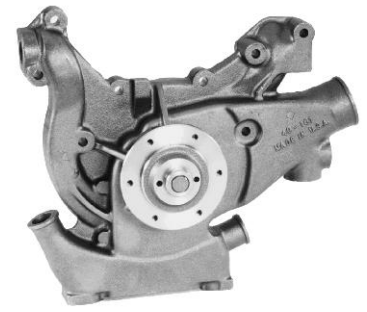

**CASTING #**  
8920383, 8924657

*8 Cylinder Diesel  
Without Heater Outlet*

**OEM #**  
8928672X

**7120X**  
**8.2 L ENGINE**

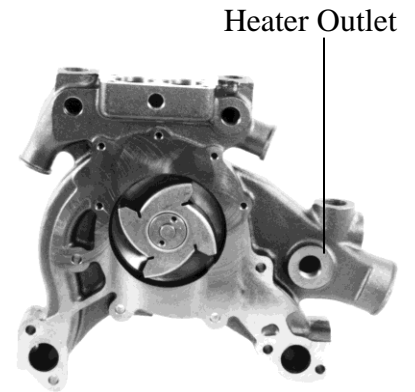

**CASTING #**  
8828804

*8 Cylinder Diesel  
With Heater Outlet which goes  
To Oil Cooler*

**OEM #**  
23509067, R23514989  
23505019

**7121X**  
**60 SERIES ENGINES**

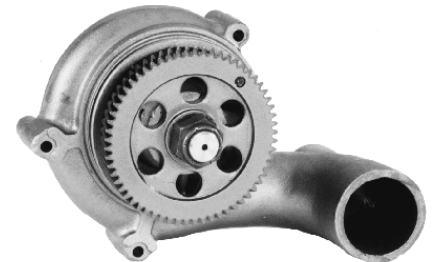

**CASTING #**  
23505018, 8929511

*Front Mount 1987-1990*

**OEM #**  
23505895, R3520136  
R3505895

**7122X**  
**60 SERIES ENGINES**

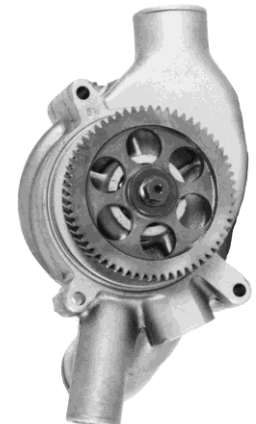

**CASTING #**  
23505894, 23516416

*1/4" Pipe Port  
Rear Mount, after 12/90  
7 Vane Impeller*

**DETROIT**



**7124X**  
**V6 & V8 ENGINES**

*Walking, w/1 outlet pointing down &  
1)outlet @ 45deg angle  
Snap Ring Back Cover  
Reverse Gear, High Capacity*

**OEM #**  
23506604

**CASTING #**  
8921100, 8922325



**7125X**  
**V16 ENGINE**

**OEM #**  
23501947

**CASTING #**  
89227237, 5140009



**7126X**  
**50 & 60 SERIES ENGINES**

*w/6 Vane Impeller  
High Capacity  
3/8" Pipe Port  
Aluminum Back Plate*

**OEM #**  
23522707

**CASTING #**  
23517027



**7126SX**  
**50 & 60 SERIES ENGINE**

*7126X with Steel Back Plate*

**OEM #**  
23522707X

**CASTING #**  
23517027



# DETROIT

OEM #  
23526039

CASTING #  
23522721

## 7127X 50 & 60 SERIES ENGINE

*6 Vane Impeller,  
High Capacity  
Has Kangaroo Pouch  
See Following Page for more Info*



*View of Kangaroo Pouch  
Shown Without Gear*

7127X

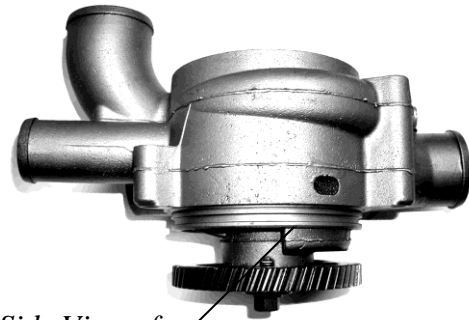

*Side View of  
Kangaroo Pouch*

OEM #  
23531245, 23531257

CASTING #  
23530427

## 7141X 50 & 60 SERIES ENGINE

*Front Mount, EGR, 14L  
Application prior to 12/90*



**7122X**



*1/4" Pipe Port*

*Rear Mount  
After 12/90  
1/4" Pipe Port*



**7126X**  
*Supercedes 7122X*



*3/8" Pipe Port*

*6 Vane Impeller  
High Capacity  
3/8" Pipe Port*



**7127X**  
*Supercedes 7126X  
Has "Kangaroo Pouch"*



*Viewed Without Gear  
So that Kangaroo Pouch  
Is visible*

*6 Vane Impeller  
High Capacity  
Kangaroo Pouch*



**DETROIT**



**7142X**  
**50 & 60 SERIES ENGINE**

**OEM #**  
23531258

*EGR, 14L*

**CASTING #**  
23530429

*Same as above  
except  
smaller pulley*

**7143X**  
**6 CYL ENGINE**





**OEM #**  
23509200

**9160X**  
**60 SERIES ENGINE**

**CASTING #**  
23523972

*Accessory Drive with  
2 Groove V Belt Pulley (4 3/4")*



**OEM #**  
23509201

**9161X**  
**60 SERIES ENGINE**

**CASTING #**  
23523972

*Accessory Drive with  
5" Multi-Groove Pulley  
(6 Grooves)*



**OEM #**  
23509200

**9162X**  
**60 SERIES ENGINE**

**CASTING #**  
23509201

*Accessory Drive  
Without Pulley  
Can be used to Replace 9160X  
and/or 9161X if pulley is retained*

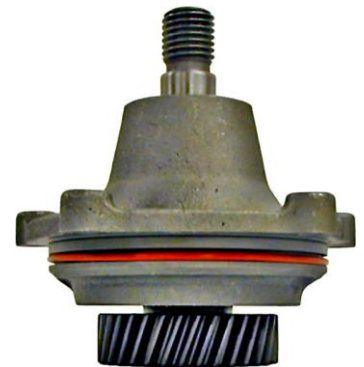

**OEM #**  
23524001, 23523998

**9163X**  
**60 SERIES ENGINE**

**CASTING #**  
23523972M

*Accessory Drive with  
8 Multi Groove Pulley  
This Housing is longer  
than the 9162X*

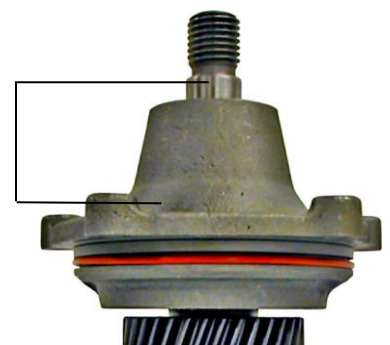

Shown without Pulley

# DETROIT

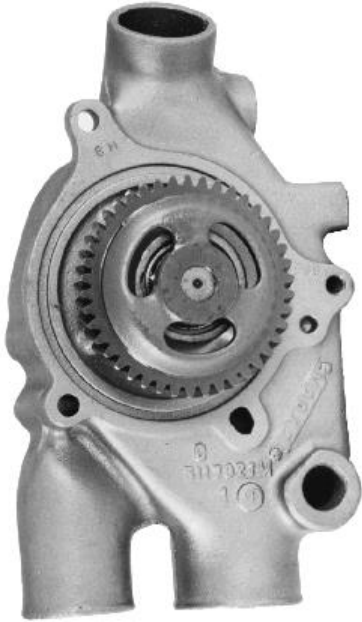

**STANDING**

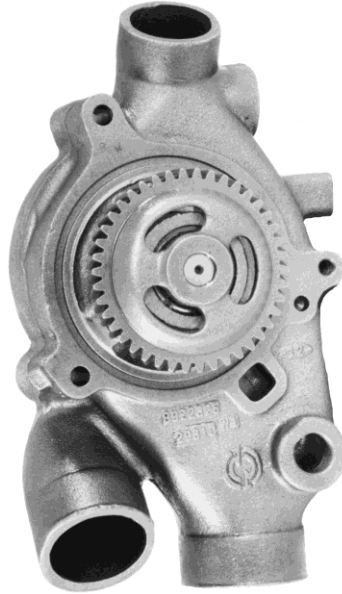

**WALKING**

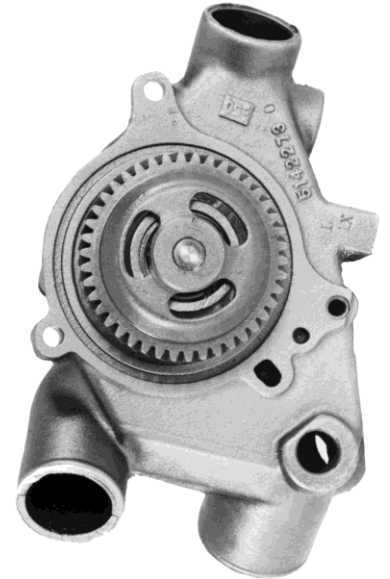

**RUNNING**

7105X	STANDING Non Turbo	STANDARD CAPACITY
7107X	STANDING Turbo	HIGHCAPACITY
7112X	STANDING	Bolt on Cover Plate on Back
7118X	STANDING Turbo	HIGH CAPACITY Reverse Gear from 7107X
7109X	Walking	Snap Ring Cover Plate on Back
7111X	Walking	Bolt on Cover Plate on Back
7108X	RUNNING Turbo	HIGH CAPACITY
7106X	RUNNING Non Turbo	STANDARD CAPACITY
7110X	Running	Snap Ring Cover Plate on Back
7115X	Running Turbo	HIGH CAPACITY Reverse Gear from 7108X

**OEM #**  
4723690, 5010964AA

**CASTING #**  
1927-10

**7063X**  
**RAM 2500, 3500 TRUCK (L6)**

*5.9L (360) Cummins Diesel  
2007-1994*

Notice Mount Differenece



**OEM #**  
4429404

**CASTING #**  
1927-10, 4104553  
0910416 4095700

**7063X**  
**D SERIES TRUCK (L6)**

*5.9L (360) Cummins Turbo Diesel  
1993-1989*



**OEM #**  
4429404, 4723690

**CASTING #**  
3903357

**7063X**  
**W SERIES TRUCK (L6)**

*5.9L (360) Cummins Turbo Diesel  
1993-1989*



**OEM #**  
5138057AA

**CASTING #**  
n/a

**7085X**  
**SPRINTER (L5))**

*2.7 L 2500, 3500  
2006-2004*



**7086X**

**OEM #2808679**  
**CASTING #2883663, 2128284**

*A100 VAN L(6)*  
*1970-1969*  
*2.8L (170), 3.2L (198), 3.7L (225)*

**OEM #3420050, 2808679, 2196910**  
**CASTING #2863063, 2883663,**  
**2128284**

*P100, 200, 300 SERIES VAN (L6)*  
*1974-1967*  
*3.7L (225)*

**OEM #2196910, 3420050**  
**CASTING #2863063**

*A100 VAN (L6)*  
*1968-1964*  
*2.8L (170), 3.7L (225)*

**OEM #4131243, 4106034, 3420050,**  
**2808679**  
**CASTING #4104553, 4095700,**  
**0910416, 2863063, 2883663**

*RAMCHARGER*  
*1980-1974*  
*3.7L (225)*

**OEM #4131243, 4106034, 3420050,**  
**2808679**  
**CASTING #4104553, 4095700,**  
**0910416, 2863063**

*SERIES 400-1000*  
*1977-1967*  
*3.7L (225)*

*B SERIES VAN (L6)*  
*1987-1971*  
*3.2L (198), 3.7L (225)*

*W SERIES TRUCK (L6)*  
*1977-1969*  
*3.2L (198), 3.7L (225) Series 400-1000*

**OEM #4131243, 4106034, 3420050,**  
**2808679, 2196910**  
**CASTING #2863063, 2883663,**  
**2128284**

*W SERIES TRUCK (L6)*  
*1968-1967*  
*2.8L (170), 3.7L (225), D400, 500,*  
*P400; S400,500; L600*

*D SERIES TRUCKS (L6)*  
*1987-1961*  
*2.8L (170), 3.2L (198), 3.7L (225)*

**7087X****OEM #53021018AB, 53021018,  
53020280  
CASTING #53020135**

*DAKOTA (V6)  
2003-1993  
3.9L (239)*

*DAKOTA (V8)  
2003-1993  
5.2L (318), 5.9L (360)*

*DURANGO  
2000-1998  
5.2L (318), 5.9L (360)*

**OEM #53021018AB, 53021018AC,  
53021018, 53020280  
CASTING #53020135**

*DURANGO (V6)  
1999-1998  
3.9L (239)*

**OEM #53021018AB, 53020280  
CASTING #53020135**

*RAM 1500, 2500, 3500 TRUCK (V6)  
2001-1994  
3.9L (239)*

*RAM 1500, 2500, 3500 TRUCK (V8)  
2001-1994  
5.2L (318), 5.9L (360)*

*RAM 1500, 2500, 3500 VAN (V6)  
2003-1999  
3.9L (239)*

*RAM 1500, 2500, 3500 VAN (V8)  
2003-1998  
5.2L (318), 5.9L (360)*

*RAMCHARGER (V8)  
1993  
5.2L (318), 5.9L (360)*

*W SERIES TRUCK (V6)  
1993  
3.9L (239)*

*W SERIES TRUCK (V8)  
1993  
5.2L (318), 5.9L (360)*

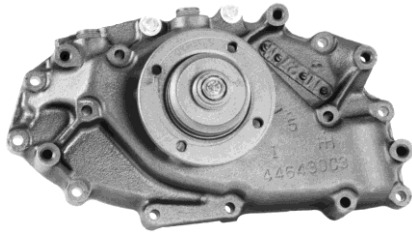

**7304X**  
**SERIES E100/350 VAN (V-8)**

*6.9 & 7.3 Liter  
E100-350 Van (V-8)  
F250/350 Pick Up (V-8)  
F59 Stripped Chassis*

**OEM #**  
E4TZ-8501B  
E9TZ-8501C

**CASTING #**  
446430C1

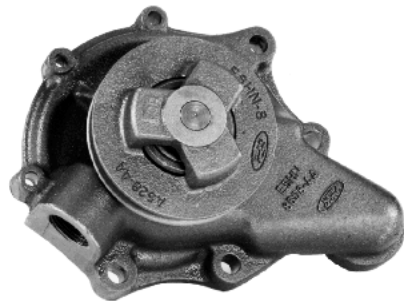

**7306X**  
**SERIES 400-1100 (V-6)**

*7.8 Liter  
No Auxiliary Mount  
1" Outlet Port*

**OEM #**  
E7HZ-8501A  
E8HZ-8501CRM

**CASTING #**  
E7HN-8508AB

**OEM #**  
E8HZ-8501B  
E8HZ-8501C, CRM

**CASTING #**  
E7HN-8508AA

**7307X**  
**SERIES 400-1100 (V-6)**

*7.8 Liter  
Has Auxiliary Mount  
3/4 " Outlet*

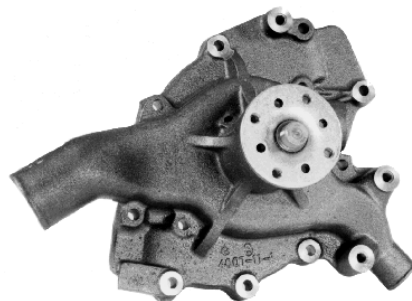
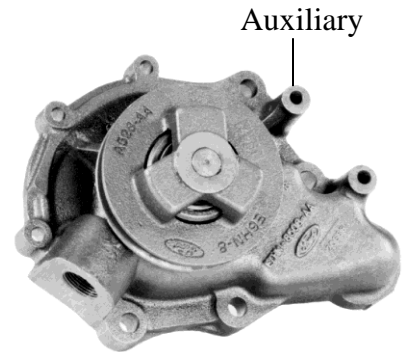

**7309X**  
**SERIES 400-1100 (V-8)**

*Series 400-1100 (V-8)*

**OEM #**  
D9HZ-8501A,F5HZ-8501AA  
E2HZ-8501B,F1HZ-8501E  
E5HZ-8501A

**CASTING #**  
E2TE-8505AA,F1HE-8505CA  
F5HE-8505AA, E4TE-AA

**OEM #**  
F1HZ-8501CRM  
F1HZ-8501C

**CASTING #**  
FOHN-8508AA

**7311X**  
**SERIES 400-1100 (V-6)**

*6.6 – 7.8 Liter  
Single Pulley 1991- 1993  
(7319X has double pulley)*



**OEM #**  
F5TZ-8501ARM, BRM,  
CRM

**CASTING #**  
1822823C1

**7314X**  
**VAN OR PICK UP**

*7.3 Direct Injection (445)  
E100/350 Van (V-8)  
F250/350 Pick Up (V-8)  
F53 Stripped Chassis*

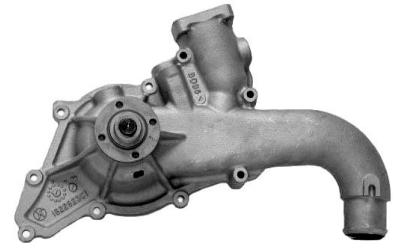

**OEM #**  
F4TZ8501ARM

**CASTING #**  
1818182C3

**7316X**  
**7.3 LITER ENGINE**

*Direct Engine (445)*

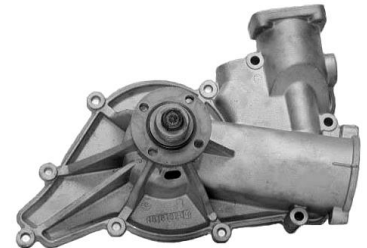

**OEM #**  
E7TZ8501ARM

**CASTING #**  
1823423C2

**7317X**  
**7.3 LITER ENGINE**

*Direct Engine (445)  
1997 Application*

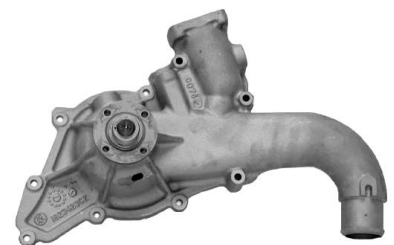



# FORD



## **7314X**

**7.3L DIRECT INJECTION**  
**F5TZ-8501A, B, CRM**  
**1994-1996 Applications**

Casting #  
**1822823C1**

## **7317X**

**7.3L DIRECT INJECTION**  
**E7TZ-8501ARM**  
**1997 Application**

Casting #  
**1823423C2**

## **2- PIECE DESIGN ALUMINUM HOUSING**

### **7320X**

**E150/350**  
**2000-2001**  
**F6TZ-8501AA**

### **7320X**

**EXCURSION**  
**2000-2001**  
**F7TZ-8501BRM**

### **7320X**

**F250/350/450/550**  
**SUPER DUTY**  
**1996-2001**  
**F81Z-8501ARM**

### **7320X**

**F53/59**  
**STRIPPED**  
**CHASSIS**  
**1996-1997**  
**F81Z-8501CRM**



**OEM #**  
E6TZ8501A, BRM

**CASTING #**  
1823611C1

**7318X**  
**7.3 LITER ENGINE**

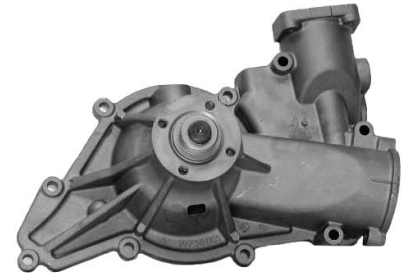

*Direct Engine (445)  
1998 & Up Application*

**OEM #**  
F1HZ-8501DRM  
F1HZ-8501D

**CASTING #**  
E8HN-8508AB

**7319X**  
**SERIES 400-1100 (V-6)**



*6.6 Engine (401)  
(Similar to 7311X)*

**OEM #**  
F7TZ-8501BRM, CRM  
F8IZ-8501ARM

**CASTING #**  
1831005C2, 1823611C1

**7320X**  
**FORD TRUCK 7.3 L**

*E Super Duty Vans (V-8)  
E100/350 Van (V-8)  
Excursion (V-8)  
F250/350 Pick Up (V-8)  
F59 Stripped Chassis*

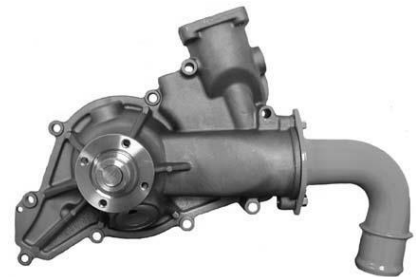

**OEM #**  
YC3Z-8501A

**CASTING #**  
1831576C1

**7322X**  
**FORD SUPER DUTY**

*F650-750  
2000 - 2003*



# FORD

## 7323X

**6.0 DIESEL ENGINE**

**OEM #**

3C3Z-8501A  
4C47-8501AARM

**CASTING #**



*Ford Super Duty Pick-Up  
2003-9/2005  
Hub Height 3.09"*



## 7324X

**6.0 DIESEL ENGINE**

**OEM #**

4C3Z-8501ABRM

**CASTING #**



*Ford Super Duty Pick Up  
9/2005 and up  
Hub Height 3.11"*

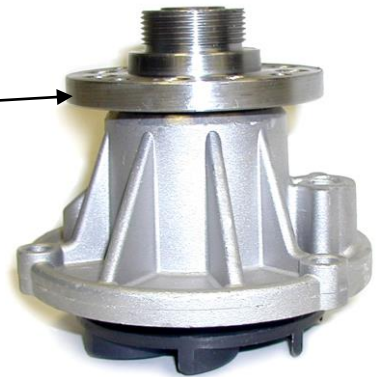

## 7327X

**F650, F750**

**OEM #**

1845002C91  
5C4Z-8501-AA

**CASTING #**

9349



# FORD TRACTOR & INDUSTRIAL

No Picture  
Available  
At this time

## **7330X** 3 CYL ENGINE

**OEM #**  
D5NN-8501E

**CASTING #**  
D4NN-8508A,  
D5NN-8505A

2000 thru 7000 Series Gas or  
Diesel with Single Groove Pulley  
& 4.100" Impeller 74-71

No Picture  
Available  
At this time

## **7331X** 3 CYLINDER ENGINE

**OEM #**  
C5NN-8501A  
D5NE-8501A

**CASTING #**  
C5NE-8508A

See Sheet to follow for Applications

No Picture  
Available  
At this time

## **7332X** 4 CYLINDER ENGINE

**OEM #**  
D1JJ-8501C

**CASTING #**  
N/A

See Sheet to Follow for Applications

No Picture  
Available  
At this time

## **7333X** 4 CYL ENGINE

**OEM #**  
FAPN-8A513AA

**CASTING #**  
E8NN-8505

Models ( 5110, 5610, 6610, 6810,  
7410, 7610, 7710, All 11/88 & Up)  
7010 4/96 & Up (All w/threaded 2  
Belt Pulley) 1996-81

# FORD TRACTOR & INDUSTRIAL

**OEM #**  
CDPN-8501C  
EAF-8501C

**CASTING #**  
EAF-8505

**7334X**  
**4 CYLINDER ENGINE**

*No Picture  
Available  
At this time*

*See Sheet for Multiple Applications*

**OEM #**  
2N-8501, 8N-8501  
9N-8501

**CASTING #**  
N/A

**7335X**  
**6 CYLINDER ENGINE**

*No Picture  
Available  
At this time*

*Model 2N, 8N, 9N  
1952-39*

**OEM #**  
F6JE-8501BA

**CASTING #**  
F6TE-8505LA

**7336X**  
**6 CYL ENGINE**

*No Picture  
Available  
At this time*

*4.9L (300) Industrial Engine*

**OEM #**  
C9NN-8501B  
DHPN-8A513B

**CASTING #**  
C5NE-8505A

**7337X**  
**6 CYLINDER ENGINE**

*No Picture  
Available  
At this time*

*7/1976-1968 8000, 8200, 8400  
1/1976-1974 9000, 9200*

# FORD TRACTOR & INDUSTRIAL

<p>No Picture Available At this time</p>	<p><b><u>7338X</u></b> <b>4 CYLINDER ENGINE</b></p>	<p><b><u>OEM #</u></b> CDPN-8501B  <b><u>CASTING #</u></b> n/a</p>
<p>No Picture Available At this time</p>	<p><b><u>7339X</u></b> <b>4 CYLINDER ENGINE</b></p> <p>4310, 4610, 4810, 39 Series (Larger Mounting Holes than 7331X) Has larger bearing</p>	<p><b><u>OEM #</u></b>  <b><u>CASTING #</u></b></p>
<p>No Picture Available At this time</p>	<p><b><u>7340X</u></b> <b>4 CYLINDER ENGINE</b></p> <p>2000, 3000, 4000, 5000, 7000, 2600, 3600, 4100, 4600, 5600, 5700, 6600, 6700, 7600, 7700, (2310, 2610, 2810, 2910, 3610, 3910, 4110, 4610 All 2/90) with 5/16 " &amp; 7/16 " Mounting Holes, 2 Groove Pulley Large Bearing</p>	<p><b><u>OEM #</u></b> EAPN-8A513A EGPN-8A513CA  <b><u>CASTING #</u></b> D8NN-8508EB EAP-8A513-E</p>
<p>No Picture Available At this time</p>	<p><b><u>7341X</u></b> <b>4 CYLINDER ENGINE</b></p> <p>6700 thru 7700 w/ 5/16" &amp; 3/8" Mounting Holes, Same as 7340 Except has Smaller Mounting Holes</p>	<p><b><u>OEM #</u></b> FAPN-8A513AD3  <b><u>CASTING #</u></b> D8NN-8508EB EAP-8A513-E</p>

**OEM #**  
3C3Z-8501ABRM  
4C47-8501AARM

**2323**  
**6.0 DIESEL ENGINE**

*Turbo Powerstroke  
F Series 2004-2003  
Excursion 2005-2003  
2003-9/2005*



**OEM #**  
4C3Z-8501ABRM

**2324**  
**6.0 DIESEL ENGINE**

*Turbo  
F250, 350, 450, 550 Super Duty  
F Series , King Ranch, Lariat, T, XL, XLT  
9/2005 & up*



**2323**  
**TOP VIEW**



**2324**  
**TOP VIEW**



# FORD TRACTOR & INDUSTRIAL

## 7330X

### 3 CYLINDER

#### 1974-1971

All 2000 thru 7000 Series  
Gas or Diesel  
with Single Groove Pulley  
\$ 4.1" Impeller

#### 1975-1971

All 2000 thru 7000 Series  
Gas or Diesel  
With Single Groove  
Pulley & 4.1" Impeller

## 7331X

### 3 CYLINDER

#### 1970-1965

2000, 3000, 4000 Series Gas  
or Diesel with Single  
Groove Pulley & 3.5" Dia  
Impeller

#### 1970-1965

5000 Gas or Diesel;  
(w/Single Groove Pulley &  
3.5 "Dis Impeller (can you a  
7330X)

## 7332X

### 4 CYLINDER

134, 172, 192 Gas or  
Diesel  
2000, 3000, 4000, 5000,  
7000, (2600, 3600, 4100,  
4600, 5600, 5700), 6600,  
6700, 7600, 7700, 2310,  
2610, 2810, 2910, 3610,  
3910, 4110, 4610 All 2/90  
w 5/16" & 7/16"  
Mounting Holes  
Large Bearing

## 7334X

### 4 CYLINDER

#### 1969-1965

134, 172 Tractor & Industrial Gas Models 600, 700, 800, 900, 2000, 4000 Series Diesel Models

#### 1964-1959

Series 500D, 501D, After Serial #153775; 600D, 601D, 700D, 701D, 2030D, 2031D, 2110D, 2111D, 2120D, 2130D. 2131D with 144 Diesel

#### 1964-1958

Series 800D, 801D, 900D, 901D 1800, 4030D, 4031D, 4040D, 4110D, 4120D, 4121D, 4121D, 4130D, 4131D, 4140D w/ D172 Diesel

#### 1964-1955

Series 800, 801, 900, 901, 1800, 1801, 4030, 4031, 4040, 4110, 4121, 4130, 4131, 4140  
w/ 172 Gas or L.P.G.

#### 1964-1955

Series NAA, 501, 541, 600, 601, 611, 620, 621, 630, 631, 640, 641, 650, 651, 660, 661, 671, 700, 701, 740, 741, 771, 2030, 2031, 2110, 2111, 2120, 2130, 2131 w/ 134 Gas or L.P.G.

#### 1957-1955

Series NAA 600, 620, 621, 630, 631, 640, 641, 650, 651, 6650, 661, 700, 740, 741 with 134 Kerosene Engine

#### 1957-1955

800K, 900K with 172 Kerosene Engine

# FORD TRACTOR & INDUSTRIAL

## 7333X

### 4 CYLINDER

1996-1981

Models (5110, 5610,  
6610, 6810, 7410, 7610,  
7710 all 1/88 & Up)  
All with threaded 2 Belt  
Pulley

## 7335X

### 4 CYLINDER

1952-1939

Model 2N, 8N, 9N

## 7336X

### 6 CYLINDER

4.9L (300) Industrial  
Engine

## 7339X

4310, 4610, 4810,  
39 Series  
Larger Mounting Holes  
than 7331X, Has a larger  
Bearing



**E SUPER DUTY VANS (V-8)****7320X***2002-1996*

7.3l (446) (F) Direct Injection Turbo Diesel

**7304X***1994-1989*7.3l (446) (m) E250/350,  
Diesel Non-Turbo*1988-1983*6.9 L (420) (1) 7.3L  
(466) (M) E250/350  
Diesel**E 100/350 VAN (V-8)****7314X***1995-1995*7.3L (466) (F) E250/350  
Direct Injection Turbo  
Diesel**7320X***1999-1996*7.3L (466) (F) E250/350  
Direct Injection Turbo  
Diesel*2003-2000*7.3L (466) (F) E350  
Direct Injection Turbo  
Diesel**EXCURSION (V-8)****7320X***2003-2000*

7.3L (466) (F) Diesel

# FORD TRUCK

## 7304X

1994

7.3L (466) (K) F250/350 Indirect Injection Turbo Diesel

1994-1988

7.3L (466) (M) F250/350 Diesel Non Turbo

1993

7.3 L (466) (C) F250/350 Turbo Diesel

1987-1983

6.9L (420) (1) 7.3L (466) Diesel F250-350

## F250/350 PICKUP (V-8)

## 7314X

1995-1994

7.3L (466) (F) F350/350  
Direct Injection Turbo  
Diesel

## 7320X

1997-1996

7.3L (466) (F) F250/350  
Direct Injection Turbo  
Diesel

## FORD SUPER DUTY

### 7322X

2000 & UP  
F650/750

## F53 STRIPPED CHASSIS

### 7314X

1996-1995  
7.3l (466) Direct Injection Turbo  
Diesel

**7304X**

1994  
7.3L (466) (K) Indirect  
Injection Turbo Diesel

1994-1989  
7.3L ( ) (M) Diesel Non  
Turbo

**F59 STRIPPED CHASSIS****7314X**

1995-1994  
7.3L (466) (F) Direct  
Injection Turbo Diesel

**7320X**

1997-1996  
7.3L (466) (F) Direct  
Injection Turbo Diesel

**SERIES 400-1100 (V-6)****7306X**

**7.8L**

**7307X**

1991  
6.6L (401) 7.8L (476) Diesel B-F L160/L900

1990-1988  
6.6L (401) 7.8L (476) FNH Diesel

1987  
6.6L (401) F600

1987  
1987 7.8L (476) CF600/800

**7311X**

1995-1994  
6.6L (401) B-C-CF-F800 without Water  
Pump Mounted Fan

1993-1991  
6.6L (401) C600-F800 Diesel with Water  
Pump Mounted Fan Exc 210 H.P.

1993-1991  
6.6L (401) 7.8L (476) Diesel B-F-FT-  
L600/L900 (From 10/1/90) without Water  
Pump Mounted Fan

**7319X**

1995-1994  
6.6L (401) B-C-CF-F800 With Water Pump  
Mounted Fan

1993-1991  
6.6L (401) C600/F800 Diesel With Water  
Pump Mounted Fan Exc 210 HP

1993-1991  
6.6L (401) 7.8L (476) Diesel B-F-FT-  
L600/L900 (From 10/1/90) With Water Pump  
Mounted Fan Exc 210 HP

**SERIES 400-1100 (V-8)**

**7309X**

1997-1991

7.0L 370, 429

1995-1991

7.0L (429) CF800, CFt800 (LPG Gas Only)

1990-1982

7.0L 370, 429

1981-1979

370, 429B, F600-800

1981-1979

370, 429C, CT600/800

1981-1979

370, 429L, LN, LNT, LT, LTS800

**NOTES:**

**OEM #**  
5135595,5149706  
23506723

**CASTING #**  
5135601,5178317,  
5135602, 5149707

**7103X**  
**MEDIUM &  
HEAVY DUTY 6 CYL**

*Medium & Heavy Duty  
Series 50, 60, w/6-71 Diesel Engine  
Left Hand Mount 1978-1973*



**OEM #**  
51355965, 5149707,  
5178318, 23506735

**CASTING #**  
5135602, 5178318,  
8920925

**7104X**  
**MEDIUM &  
HEAVY DUTY 6 CYL**

*1978-1973  
Series 50, 60, 65 w/ 6-71 Diesel Engine  
Right Hand Mount*



**OEM #**  
5135596

**CASTING #**  
5135602

**7104X**  
**MEDIUM & HEAVY DUTY 6 CYL**

*1974-1939  
450-900 Series 3-71, 4-71, 6-71,  
Diesel Eng Exc 6-71T  
Right Hand Mount*



**OEM #**  
10074182

**CASTING #**  
14001939

**7116X**  
**MEDIUM & HEAVY DUTY V-8**

*6.0L (366), 7.0L (427), 7.4L (454)  
60 & 70 Series 1990-76*

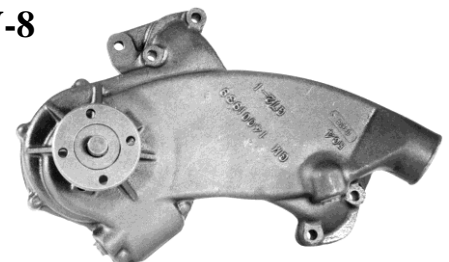

**OEM #**

12514269, 15633465

**CASTING #**

14024206

**7117X**

**MEDIUM & HEAVY DUTY V-8**

6.2L (379), C,J Diesel  
1992-81

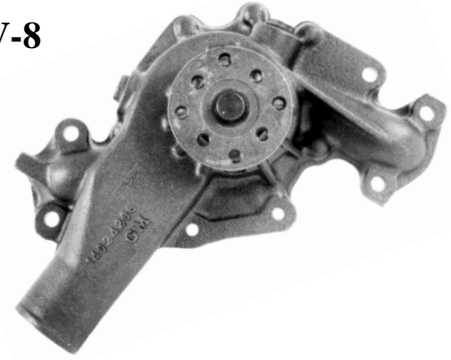

**OEM #**

12529192, 12551474  
12512740, 10140677

**CASTING #**

10241634, 14001939

**7123X**

**MEDIUM & HEAVY DUTY (V-8)**

*See page for Different Applications*



**OEM #**

**CASTING #**

**7128X**

**ENGINE**



**OEM #**

12534772,

**CASTING #**

**7129X**

**ENGINE**

6.5L (395) (F) Diesel  
B7 School Bus  
(See next page for more details)



**7148X**

**MEDIUM & HEAVY DUTY 6 CYL**

**OEM #**

10112691, 474056  
357262

**CASTING #**

465802, 352199

*4.8L (292, P4 Series  
4.8L (292), Series 50, 60,  
School Bus*

**7144X**

**MEDIUM & HEAVY DUTY V-8**

**OEM #**

88893907

**CASTING #**

N/A

*8.1L (496) (G) C4500 thru C8500  
B7 School Bus,  
C6, C7 Topkick*

**7145X**

**MEDIUM & HEAVY DUTY V-8**

**OEM #**

12456231

**CASTING #**

N/A

*7.4L (454) (B&D), B7 School Bus  
C6, C7 Topkick*

**7146X**

**MEDIUM & HEAVY DUTY V-8**

**OEM #**

6258551

**CASTING #**

330813

*5.7L (350), Series 40, 50, 60*



**7123X (V-8)**

1998-1996

6.0L (366) (P) 7.0L (427) (M) B7 School Bus (C5, C6, C7 Series)

1997

6.0L (366) (P) F6, 7 Series

1996-1990

6.0L (366) (P) 7.0L (427) (M) B7 & P6 School Bus (50, 60, 70 Series w/Screw on Hub)

1998-1990

6.0L (366) 7.1L (427) 50, 60, 70 Series School Bus

**7129X (V-8)**

1998

6.5L (395) (F) B7 School Bus, Diesel

1997

6.5L (395) (F) Diesel B7 School Bus, Exc Hazard Warning Switch (C6, C7 Series)

**7143X (6 CYL)**

1989-1988

4.8L (292), P4 Series

1987-1978

4.8L (292), Series 50, 60

1984-1983

4.8L (292) Series 50, 60, School Bus

1980-1974

4.8L (292) Series 50, 60 2<sup>nd</sup> Design

**OEM #**  
673162C92,  
673162C94

**7303X**  
**COMBINE 6 CYL ENGINE**



**CASTING #**  
675806C2, 675806C3

*815, 915 w/D414 Diesel  
All w/D436, DT436 Diesel  
All w/ D466, DT466*

**OEM #**  
673162C92,  
673162C94

**7303X**  
**TRACTOR/LOADER/CRAWLER**



**CASTING #**  
675806C2, 675806C3

*966, 1066, 1086, D414, DT414,  
D436, DT466, DT466 Diesel*



**7325X**  
**COMBINE 6 CYL ENGINE**

**OEM #**  
303395R91, 601816C91

**CASTING #**  
303394R1

Repair Kit #  
Gasket Kit #2325G

*See Applications Below*

**7325X**  
**Combine 6 Cyl Applications**

1970-1968  
SP-375 Windrower w/C175

1970-1968  
SP-315 w/D236

1970-1968  
SP-616, 622 Cotton Picker w/C301

**7325X**  
**Combine 6 Cyl Applications**

1970-1968  
SP-205, 315 w/C221

1970-1966  
SP-403 w/C263, C282, D282 (To serial #2195)

1970-1966  
SP-303 w/C221 (From serial #7278)

1970-1962  
SP-503 w/D301

**7325X**  
**TRACTOR/LOADER/CRAWLER**

**OEM #**  
303395R91, 601816C91

**CASTING #**  
303394R1

*See Below Applications*

Repair Kit #  
Gasket Kit #2325G

**7325X**  
**TRACTOR/LOADER/CRAWLER APPLICATIONS**

1980-1969

100C, LDR

1977-1971

3600A, E/c263

1977-1962

D50, W/C301, H-50, A, B, C, W/D188, UD236, UD282, D301

1977-1959

H-50, A, B, C, W/D188, UD236, UD282, D301

1975-1972

9000 W/C291, C301

1975-1967

3800, 3850 W/C263

1974-1968

H-60B, W/C301

1974-1962

TD-9B & 150 LDR

1973-1971

2500 CONSALL

1973-1969

T & TD7

1971-1965

2656 W/C263 & 3616 W/C221

1970-1961

4 Cyl Gas 504, 2504 Models

1970-1958

6 Cyl Gas 856, 2856 Models & 6Cyl Power Units UC221, 263, 291, ud188, 236, 282

**7325X**

**TRACTOR/LOADER/CRAWLER APPLICATIONS**

**1969-1958**

2706 w/C263, 291, 2756 w/C291, 2856, w/C301, H-25 PL w/D188, H-30 w/236,  
282, H-40 w/V264-6A, TD62 w/263

**1964-1958**

Farmall Diesel

**1961-1958**

Farmall 460, 560, 660 Gas Models

**ALL**

Models: H70, H86, 2606, 2706, 2756, 403, 460, 560, 606, 660, 706, 766, 806, 826, 856

***NOTES:***

# INTERNATIONAL/NAVISTAR

**OEM #**

685155C92, 685155C94  
685155C95

**CASTING #**

677856C1, 677856C2

**7301X**  
**6 CYLINDER ENGINE**

*Medium & Heavy Duty Series  
Conventional Cab  
Similar to 7310X except this  
Unit has Right Hand Threads*



**7301X**

7.6L (466) Conventional Models, DT466 (B)

1992-1990

7.6L (466) Navistar Diesel to 10/4/91, 2554, 2574, 2654, 8100, 8200, 8300

1990

6.9L (360) FD1060 Cummins Diesel, 1452, 1624, 1654, 1723, 1724, 1753, 1754, 1824, 1853, 1854, 1924, 1925, 1954, 1955, 2125, 2155 Forward Control Series

**OEM #**

680899C92

**CASTING #**

677137C91

**7302X**  
**MEDIUM & HEAVY  
DUTY 6 CYL**

*All DT466 7.6L (466) Cab Over*



**OEM #**

1805952C91,1809374C92  
1809374C91,1809374C92  
1809374C93

**CASTING #**

44643C91

**7305X**  
**MEDIUM & HEAVY DUTY 8 CYL**

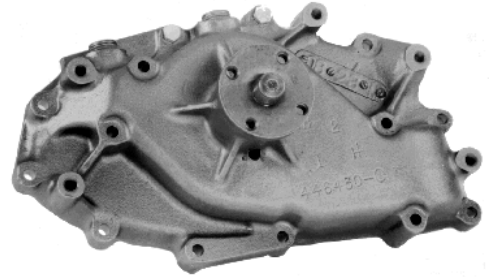

*See Applications Below*

**7305X**

**1993-1991**

7.3L (445) Navistar Diesel 1400 Metro, 1452, 1600, 1652 Forward Control Series

**1993-1991**

7.3L (445) Navistar Diesel 3600, 3700, 3800, 3900FC Bus Chassis Series 4500, 4600

**1990-1971**

6.6L (404), 6.9L (420), 7.3 (446), Cargostar, S Medium Series Gas & Diesel

**OEM #**

1700594C91,  
1700594C92

**CASTING #**

489173C1

**7308X**  
**MEDIUM & HEAVY  
DUTY 8 CYL**



**1990-1979**

9.0L (552) Diesel S Series

**1990-1976**

9.1L (552) Diesel Cargostar

***NOTES:***

# INTERNATIONAL/NAVISTAR

**OEM #**

1815538C91,735445C91  
ZGA735327

**CASTING #**

677856C1, 677856C3

**7310X**  
**MEDIUM & HEAVY  
DUTY 6 CYL**

*Left Hand, Threaded on Shaft,  
Reverse Threads  
See Below Applications*



**7310X**

**1997-1993**

5.9L (366) DT/DTA Diesel, 7.6L (466) DT/DTA Diesel 1600, 1652, 4500, 4700, 4800, 4900, 7100;  
Bus Chassis Series 3600, 3700, 3800, 3900CF

**1995**

7.6L(466) Navistar Diesel 2554, 2574, 2654, 2674, 8100, 8200, 8300 Forward Control Series  
w/o Electronically Controlled Emissions

**1994-1992**

7.6L (466) Navistar Diesel (From 10/4/91) 2554, 2574, 2654, 2674, 8100, 8200, 8300

**7301X**

*Right Hand Threads  
Tall Hub w/Small Hex Nut*

**vs**

**7310X**

*Left Hand Threads  
Short Hub w/ Large Hex Nut*

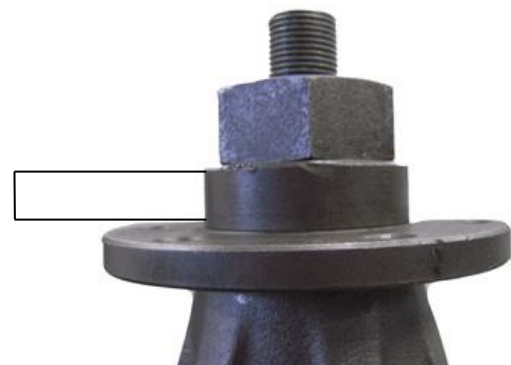
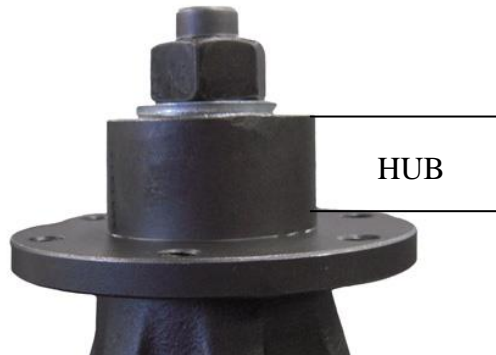



**7312X**  
**ENGINE**

**OEM #**  
463365C91

**CASTING #**  
151203R1

*Model 800, IHC Scout,  
Mail Truck  
Model CO/1600, IHC  
Scout, Mail Truck*

Repair Kit #2312RK  
Gasket Kit #2312G

**7312X**

**1984-1978**

**MEDIUM & HEAVY DUTY SERIES (8 CYL)**

5.6l v345) Gas 1452, 1624, 1652, 1654, 1723, 1724, 1753, 1754, 1823, 1824, 1853, 1924, 1925, 1954, 1955, 2125 Models

**1971**

**METRO M SERIES VANS M1100, M1200, MA1200, MS1210 (4 CYL)**

3.2L (196) Models without Fan Clutch

**1965-1963**

**METRO MITE CM SERIES VANS CM80, CM110 (4 CYL)**

2.5L (152) with Auto Fan

**1975-1974**

**PICKUP 100, 150, 200 SERIES (8 CYL)**

5.0L (304) 5.6L (345), 6.4L (392), Models without Fan Clutch

**1970-1966**

**PICKUP 1000A,B,C,D 110A, B,C,D; 1200A,B,C,D; 1300A,B,C,D Series (8 CYL)**

4.4L(266), 5.1L (304), Models without Fan Clutch

**1973-1971**

**PICKUP 1010, 1110, 1210, 1310 SERIES (8 CYL)**

4.4L (266), 5.0L (304) Models without Fan Clutch

**19968-1966**

**PICKUP 900A, 908B, 908C, SERIES (8 CYL)**

4.4L (266), 5.0L (304) Models without Fan Clutch

**1960-1959**

**PICKUP B SERIES (8 CYL)**

4.4L (266)



**7312X**

1964-1961

**PICKUP C SERIES (8 CYL)**

4.4L (266), 5.0L (304), Models without Fan Clutch

1965

**PICKUP D1000, D1100, D1200, D1300 SERIES (8 CYL)**

4.4L (266), 5.0L (304) Models without Fan Clutch



1980-1971

**SCOUT, SCOUT II TERRA, SCOUT II TRAVELER (4 CYL)**

3.2L (196), Models without Fan Clutch

1977-1966

**SCOUT, SCOUT II TERRA, SCOUT II TRAVELER (4 CYL)**

3.2L (196) with Auto Fan

1964-1961

**SCOUT, SCOUT II TERRA, SCOUT II TRAVELER (4 CYL)**

2.5L (152) with Auto Fan

1980-1971

**SCOUT, SCOUT II TERRA, SCOUT II TRAVELER (8 CYL)**

5.0L (304), 5.6L (345) Models without Fan Clutch

1975-1961

**TRAVELALL (8 CYL)**

4.4L (266), 5.5L (304), 5.6L (345), 6.4L (392), Models without Fan Clutch

1960-1959

**TRAVELALL (8 CYL)**

4.4L (266)

**OEM #**

1817687C92, 1817687C96  
1830606C94, 1830687C94,  
1817687C95

**CASTING #**

1821935C91, 1821935C3

**7313X**

**MEDIUM & HEAVY  
DUTY (6 CYL)**

*7.6l (466) Navistar Diesel 2554, 2574, 2654, 2674,  
8100, 8200, 8300 Forward Control Series; 3600,  
3700, 3800, 3900FC Bus Chassis Series  
Stamped Steel Impeller*



**OEM #**

1823669C92

**CASTING #**

1822851C1,  
1831676C91

**7315X**

**MEDIUM & HEAVY DUTY (8 CYL)**

*7.3 T444E Bus/Truck Diesel  
Right Hand*



**7321X**

**MEDIUM & HEAVY DUTY (6 CYL)  
DT466**



*2004-2005  
DT466 & 530E New  
Generation (7.6L)*

**OEM #**

1842664C92, 1841764C2  
1830607C4, 184664C92

**CASTING #**

1841765C1

**7322X**

**MEDIUM & HEAVY DUTY (8 CYL)  
T444E**

**OEM #**

YC3Z-8501A

**CASTING #**

1831576C1

*7.3 T444E Bus/Truck Diesel  
International Truck w/ Ford Engine*

# INTERNATIONAL/NAVISTAR

**OEM #**

318119R92, 303395R92

\*\*see more in Notes at  
bottom of next page

**CASTING #**

169304R1, 303394R1

**7325X**  
**MEDIUM &  
HEAVY DUTY (6 CYL)**



*BC160 To 180 Series, D301 Diesel B*

**OEM #**

357621C92

**CASTING #**

151203R1M

**7326X**

*See Below Applications*

**7326X**

**1971**

**METRO M SERIES VANS M1100, M1200, MA1200, MS1210 (4 CYL)**

3.2 L (196), Models with Fan Clutch

**1975-1974**

**PICKUP 100, 150, 200 SERIES (8 CYL)**

5.0L (304), 5.6L (345), 6.4L (392), Models with Fan Clutch

**1970-1966**

**PICKUP 1000A,B,C,D; 1100A,B,C,D; 1200A,B,C,D; 1300A,B,C,D; SERIES (8 CYL)**

4.4L (266), 5.0L (304) Models with Fan Clutch

**1973-1971**

**PICKUP 1010, 1110, 1210, 1310, SERIES (8 CYL)**

4.4L (266), 5.0L (304) Models with Fan Clutch

**1968-1966**

**PICKUP 900A, 908B, 908C, SERIES (8 CYL)**

4.4L (266), 5.0L (304) Models with Fan Clutch

**7326X**

1964-1991

**PICKUP C SERIES (8 CYL)**

4.4L (266), 5.0L (304), Models with Fan Clutch

1965

**PICKUP D1000, D1100, D1200, D1300 SERIES (8 CYL)**

4.4L (266), 5.0L (304) Models with Fan Clutch

1980-1971

**SCOUT, SCOUT II TERRA, SCOUT II TRAVELER (4 CYL)**

3.2L (196) Models with Fan Clutch

1980-1971

**SCOUT, SCOUT II TERRA, SCOUT II TRAVELER (8 CYL)**

5.0l (304), 5.6l (345) Models with Fan Clutch

1975-1961

**TRAVELALL (8 CYL)**

4.4L (266), 5.5L (304), 5.6L (345), 6.4L (392), Models with Fan Clutch

**OEM #**

2930-983-4192

**7086X**

**GOVERNMENT POSTAL VEHICLE**

**CASTING #**

n/a

*1 Ton Dodge Mail Truck S6-P200  
W170, 225*

**NOTES:**

**7325**

**OEM Numbers**

**749170C91, 601816C92,  
395813R91, 368496R91,  
323877R11, 308383R91,  
303396R91, 303395R91,  
601816C91, 318119R92,  
318119R91, 318118R21,**

# INTERNATIONAL

**7097X**

**Cummins ISX Engine**

**OEM #**

n/a

**CASTING #**

3683652

*9200 International  
2013-2007*



OEM #  
11-4576

**7350X**  
**MEDIUM DUTY (4 CYL)**

CASTING #  
PH374

*C201PT (2.2) Diesel,  
Refrigeration Unit*

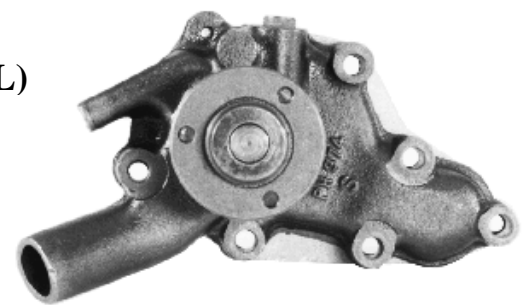

OEM #  
11-5858

**7351X**  
**ENGINE**

CASTING #  
M1 or M2

*2.2L Direct Injection*

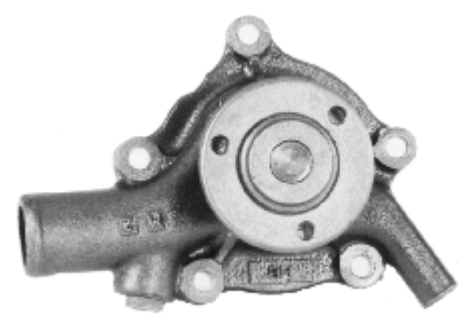

OEM #  
11-5858

**7352X**  
**ENGINE**

CASTING #  
n/a

*2.2L  
Same as 7351, but does not have  
extra port*

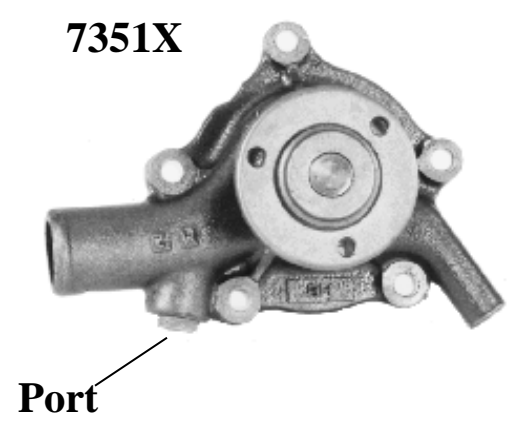

**OEM #**  
8-94391-670-5

**7353X**  
**MEDIUM DUTY (4 CYL)**

*Picture not  
Available  
At this time*

**CASTING #**  
n/a

*R&R  
Available*

2002-2000

**OEM #**  
8-12524-498-0

**7354X**  
**NPR TRUCK (V-8)**

*Picture not  
Available  
At this time*

**CASTING #**  
10108457

*R&R  
Available*

5.7L (350)

## **WATER PUMP GASKETS**

**Are Included in Each box for Mounting Purposes  
But can Also be purchased individually**



**Application**

KUBOTA TRACTOR  
L235, L235DT, L235F,  
L275, L275DT, L355,  
L3350DT, L355SS,  
L4350

Cross Reference  
15521-73033,  
15521-73035,  
15521-73039



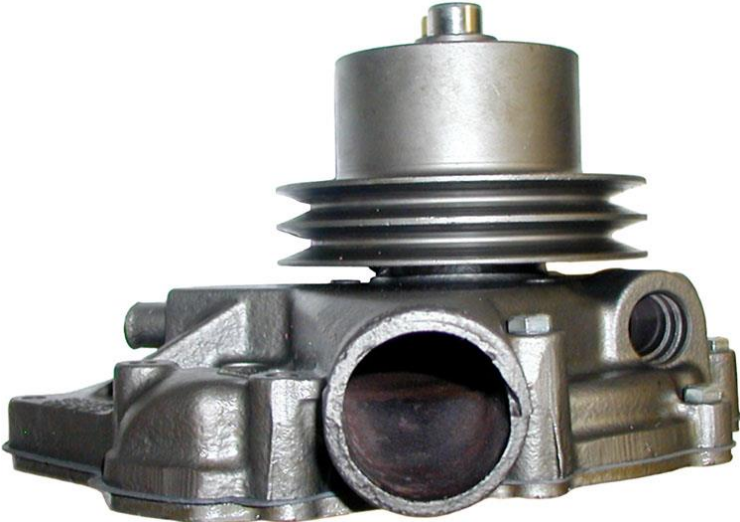

*John Deere Units  
Available for R & R*

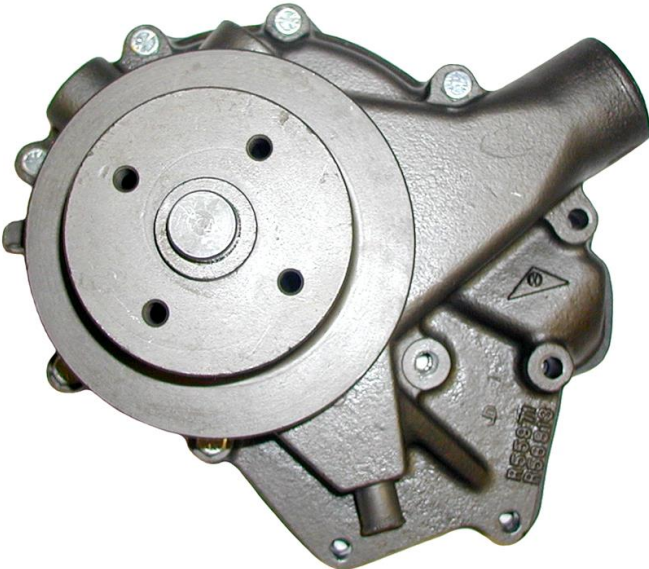



## MACK PUMPS

PART #	SHAFT	HOUSING			
7201X	1 ½"	3.6"	END 673,675,676	No Pulley	Cast Iron Impeller
7202X	1 ½"	4"	Maxidyne ESI, ENDT, 675, 676	No Pulley	Cast Iron Impeller
7203X					
7204X	1 ½"	3.6"	Thermodyne 673, 675, 711	No Pulley	Stamped Steel Impeller
7205X	1/ ½"	4"	Maxidyne ESI, ENDT, 675, 676	No Pulley	Stamped Steel Impeller
7206X		3.6"	END 673,675,676 With Hub		Stamped Steel Impeller
7208X	1"	4"	Econodyne Charged Air E6, EM6, EMS 6	No Pulley	Stamped Steel Impeller
7209X			Econodyne Charged Air E6, EM6, EMS 6	3 Belt Pulley <i>Pulley 6 5/8"</i>	Stamped Steel Impeller
7210X			E6 Charged Air	3 Groove Pulley <i>Pulley 5 ½"</i>	Stamped Steel Impeller
7211X			Maxidyne ESI, ENDT, 675, 676	3 Groove Pulley	Stamped Steel Impeller
7212X			Maxidyne ESI, ENDT, 675, 676	4 Groove Pulley	Stamped Steel Impeller
7214X			Maxidyne ENDT 675, 676		
7215X			ESI, ENDT, 675	Notched Pulley for Fan Cluch Applications	
7216X			Econodyne E7	No Pulley	Flat Bottom Impeller
7217X			E7	3 Belt <i>Pulley (7 ¼")</i> 7 ¼" OD Metric Hous	Stamped Impeller
7218X			E7	3 Belt <i>Pulley (5 1/2:")</i> Metric Housing	Stamped Impeller
7219X			E6	3 Belt <i>Pulley (7 ¼")</i> 7 ¼" OD B Housing	Stamped Impeller
7220X			E7	No Pulley Metric Housing	Stamped Impeller
7221X			E6	<i>5 1/8" Pulley</i> 3 Belts B Housing	Flat Impeller
7222X			E7	3 Belt, Long Pulley Metric Housing	
7223X			E7	3 Belt <i>Pulley (6 5/8")</i> Metric	
7224X			E7	3 Belt Long Pulley Metric Housing	
7225X			E7	No Pulley Metric Housing	
7226X			E7	<i>5 ½" Multi Groove</i> Pulley & 1V Belt Pulley	
7227X			E7	<i>6 5/8" Multi Groove</i> Pulley & 1V Belt Pulley	
7228X			E7	<i>6 ¼" Multi Groove</i> Pulley & 1V Belt Pulley	
7229X			E7	Long Multi Groove Pulley	
7230X			AESP	5 ¼" Pulley	
7230LX			Granite CV13 ENG 460	Same as 7230X except has Larger Pulley	
7231X			E7	Same as 7220X except Has Heavy Duty Bearing	

**OEM #**  
316GC184

**7201X**  
END 673, 675, 676

**CASTING #**  
360GB334

*Short Shaft, No Pulley,  
Cast Iron Impeller*

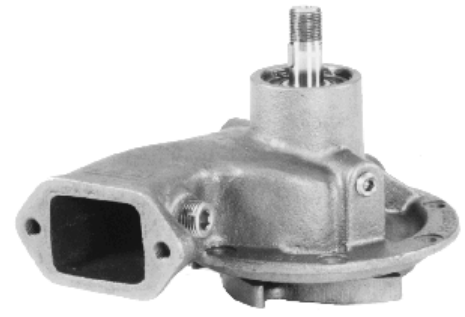

**OEM #**  
316GC1184  
316GC1211A,B

**7202X**  
MACK E6, EM6, EMS6  
Maxidyne ESI, ENDT 675, 676

**CASTING #**  
360GB443A

*Long Shaft, (.94") No Pulley  
With Cast Iron Impeller  
Can replace with 7205X*

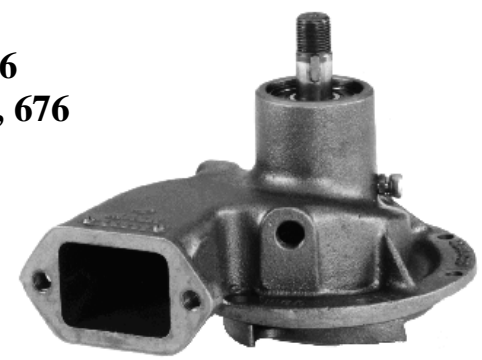

**OEM #**  
316GC1184  
316GC1211A

**7204X**  
THERMODYNE 673,675,711

**CASTING #**  
306GB334

*Short Shaft, No Pulley  
With Stamped Steel Impeller*



**OEM #**  
316GC1211B

**7205X**  
MAXIDYNE ESI, ENDT 675,676

**CASTING #**  
360GB443A

*Long Shaft, (1.57") W/O Pulley  
With Stamped Steel Impeller  
Cannot replace with 7202X*

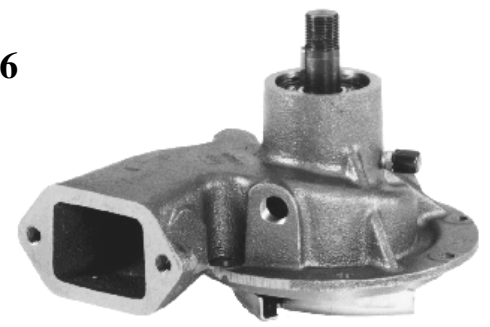

**OEM #**  
316GC184N

**CASTING #**  
360GB334

**7206X**  
END 673, 675, 676

*With Hub, Short Shaft, No Pulley  
Stamped Steel Impeller,*

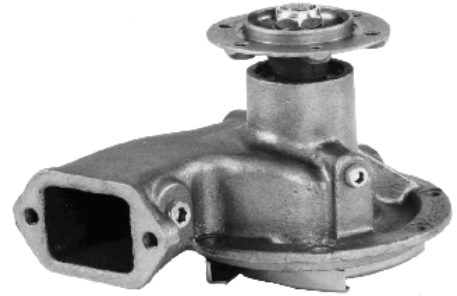

**OEM #**  
316GC1210A,  
316GC4541A,  
316GC1219

**CASTING #**  
360GB443A

**7208X**  
E7, E6, EMS6  
Econodyne, Charged Air

*E6, EM6, EMS 6  
No Pulley,  
Stamped Steel Impeller*

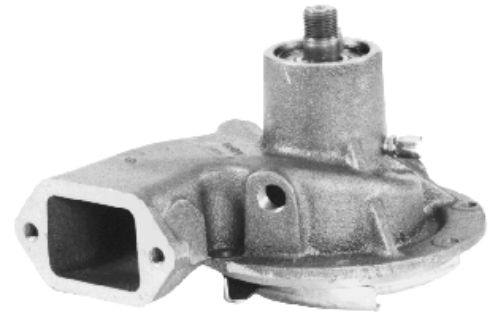

**OEM #**  
316GC1210AX

**CASTING #**  
360GB443A

**7209X**  
E6, EM6, EMS6  
ECONODYNE CHARGED AIR

*3 Groove 6 5/8" Pulley  
Stamped Steel Impeller  
Short Shaft  
Same as 7208X but with Pulley*

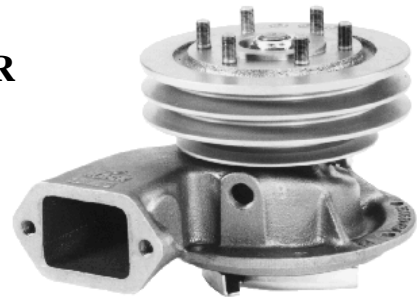

**OEM #**  
316GC528CX

**CASTING #**  
360GB443A

**7210X**  
E-6 CHARGED AIR

*3 Groove 5 1/2" Pulley  
Stamped Steel Impeller  
1973-1982*

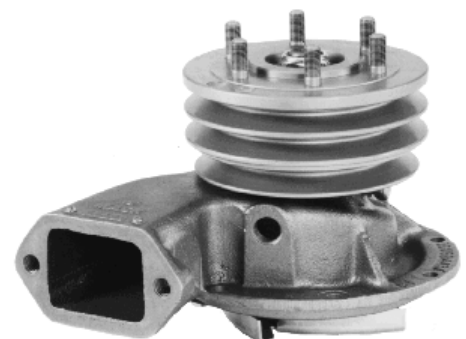

**OEM #**  
316GC523BX

**7211X**  
**MAXIDYNE ESI, ENDT 675, 676**

**CASTING #**  
360GB443A

*Long Shaft, 3 Groove Pulley  
Stamped Steel Impeller  
(Same as 7205X but w/3 groove pulley)*



**OEM #**  
316GC1184BP2X

**7212X**  
**MAXIDYNE ESI, ENDT 675, 676**

**CASTING #**  
360GB443A

*Long Shaft, 4 Groove Pulley  
Stamped Steel Impeller  
(7205X with 4 Groove Pulley)*

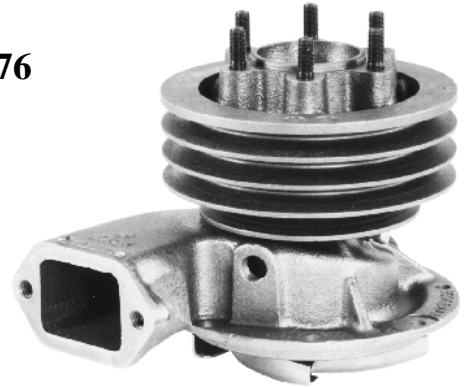

**OEM #**  
316GC1184BX

**7214X**  
**MAXIDYNE ENDT 675, 676**

**CASTING #**  
360GB443A

*Long Shaft with Pulley  
Stamped Impeller*

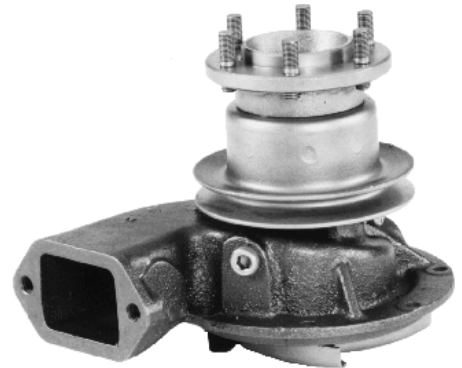

**OEM #**  
316GC1211AX

**7215X**  
**675 ESI, ENDT**

**CASTING #**  
360GB443A

*Long Shaft with Notched Hub Pulley  
For Fan Clutch Applications (Viscous)  
Stamped Impeller*



**OEM #**  
316GC1219  
316GC1219A

**CASTING #**  
360GB443A

**7216X**  
**ECONODYNE E7**

*Flat Bottom Impeller  
No Pulley*

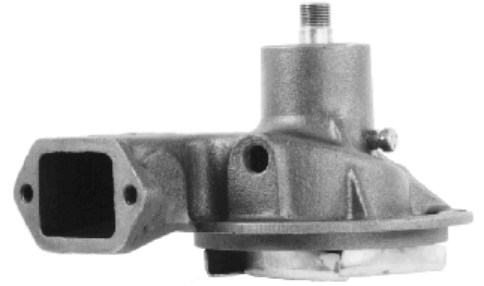

**OEM #**  
316GC548MX2

**CASTING #**  
360GB251AM

**7217X**  
**E7 ENGINE**

*3 Groove Pulley  
7 1/4" pulley. & Metric Housing  
Stamped Impeller, Short Shaft  
(7220X with pulley)*

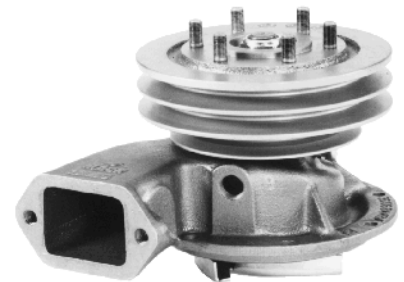

**OEM #**  
316GC548MX

**CASTING #**  
360GB251AM

**7218X**  
**E-6 ENGINE**

*Metric Housing, Stamped Impeller  
(7220X w/ 5 1/2" Pulley)*

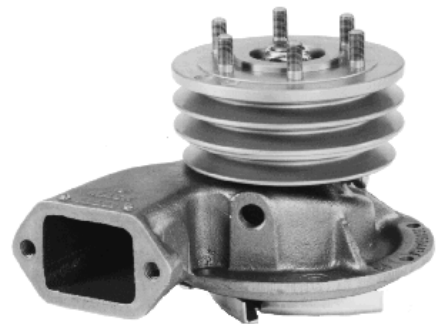

**OEM #**  
316GC549MX

**CASTING #**  
360GB443A

**7219X**  
**E-6 ENGINE**

*3 Groove 7 1/4" Pulley,  
Short Shaft w/Stamped Impeller  
B Housing, Flat Bottom*

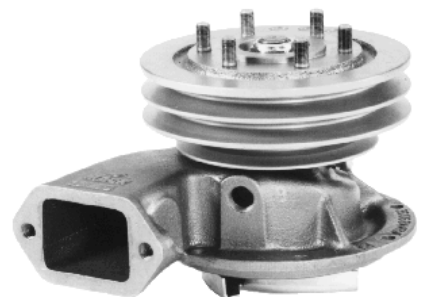

**OEM #**  
316GC284

**7220X**  
**E-7 ENGINE**

**CASTING #**  
360GB251AM

*Metric Housing & No Pulley  
Short Shaft w/ Stamped Impeller  
(7226X, 7227X, 7228X same  
units, except different pulleys)*

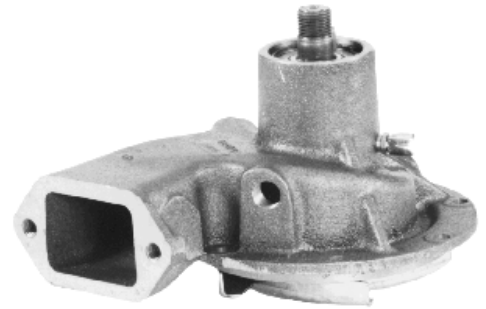

**7221X**  
**E-6 ENGINE**

**OEM #**  
316GC549M2X

**CASTING #**  
360GB443B

*Smooth(Flat) Impeller  
6 5/8" Pulley  
B Housing*

**OEM #**  
316GC4107MX

**7222X**  
**E-7 ENGINE**

**CASTING #**  
360GB251AM

*3 Belt Pulley  
Metric Housing  
Long Shaft*



**OEM #**  
316GC548M4X

**7223X**  
**E-7 ENGINE**

**CASTING #**  
360GB251AM

*3 Belt Pulley (6 5/8")  
Metric Housing  
Short Shaft*

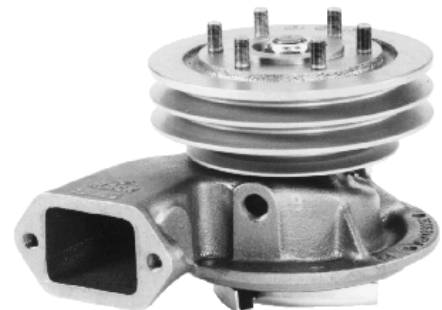



**OEM #**  
316GC4108MX

**CASTING #**  
360GB251AM

**7224X**  
**E-7 ENGINE**

*Long Shaft  
3 Belt Long Pulley  
Metric Housing*



**OEM #**  
31663285A,B,C,AC

**CASTING #**  
360GB251AM

**7225X**  
**E-7 ENGINE**

*Midliner  
Metric Housing, No Pulley  
Long Shaft  
(Same as 7229X, except no pulley)*

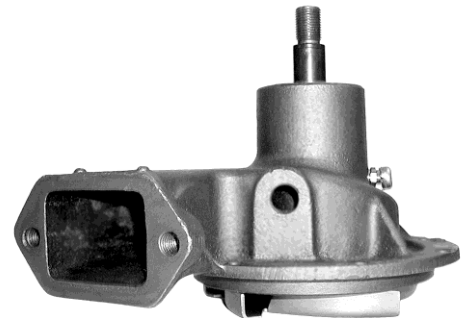

**OEM #**  
316GC551M2X

**CASTING #**  
360GB251AM

**7226X**  
**E-7 ENGINE**

*5 1/2" Multi Groove Pulley  
Short Shaft, 1 V Belt  
(Same as 7220X except  
with pulley)*

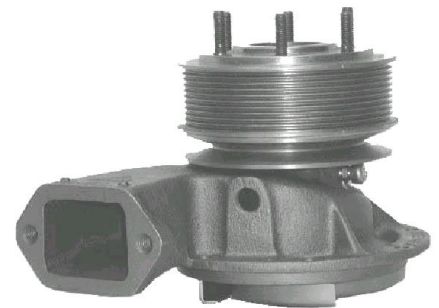

**OEM #**  
316GC551MX

**CASTING #**  
360GB251AM

**7227X**  
**E-7 ENGINE**

*6 5/8" Multi Groove Pulley  
& 1 V Belt Pulley  
Short Shaft, Metric Housing  
(Same as 7220X except with pulley)*



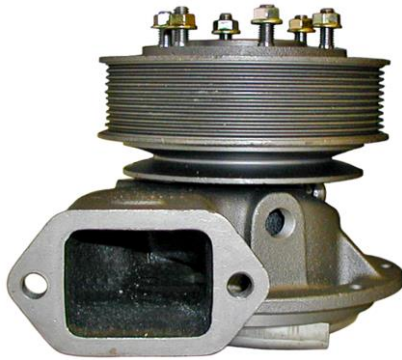

**7228X**  
**E-7 ENGINE**

**OEM #**  
316GC551M3X

**CASTING #**  
360GB52M

*6 1/4" Multi Groove Pulley  
& 1 V Belt Pulley  
Short Shaft  
(Same as 7220X except with pulley)*

**OEM #**  
316GC552M2X

**7229X**  
**E-7 ENGINE**

**CASTING #**  
360GB52M

*Long Shaft  
Multi Groove Pulley  
Metric Housing  
(Same as 7225X, except with Multi Groove*



5 1/4" pulley



**7230X**  
**MACK ACET ENGINE**

**OEM #**  
316GC3193

**CASTING #**  
2379-12

*Granite CV 13, Eng 460 E Tech*

**Pulley Casting #**  
2739-17

5 7/8" pulley

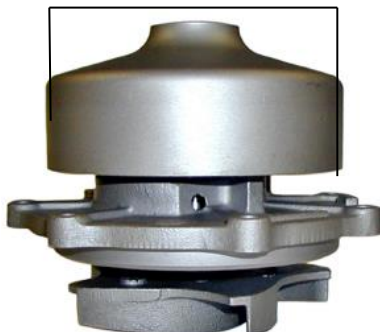

**7230LX**  
**MACK ACET ENGINE**

**OEM #**  
316GC3196

**CASTING #**  
2379-12

*Granite CV 13, Eng 460 E Tech  
(Same as 7230X except this unit  
has a Larger Pulley OD)*

**Pulley Casting #**  
2738-17



OEM #

**7231X**  
**ENGINE**

CASTING #  
360GB54M

*Same as 7220X except this unit  
Has Heavy Duty Bearing*



**NOTES:**

**7220X**

Will replace these part  
numbers with customer  
supplied pulley

**7226X**

**7227X**

**7228X**

**7225X**

Will replace this part  
number with customer  
supplied pulley

**7229X**

**OEM #**

1022115M91

1039163M91

3420050

**CASTING #**

2128284, 2863063

2883663

*Picture not  
Available  
At this tim*

*R&R  
Available*

**7086X**  
**COMBINE 6 CYL**

*205, 300 Self-Propelled Gas  
1970-62*



**7088X**  
**3 CYL TRACTOR  
LOADER, CRAWLER**

*MF-135, MF-150, MF-2135  
Using Perkins Diesel Engine  
1970-65*

**OEM #**

735036M91

**CASTING #**

37711330B

37711331,

*Picture not  
Available  
At this tim*

*R&R  
Availablee*

**7089X**  
**3 CYL TRACTOR,  
LOADER, CRAWLER**

*MF-35, MF-50, MF-203, MF-205  
Using Perkins Diesel Engines  
1964-60*

**OEM #**

734527M91

734932M91

**CASTING #**

37711330B

37711331

*Picture not  
Available  
At this time*

*R&R  
Available*

**7090X**  
**COMBINE 8 CYL**

*510 Self Propelled Gas  
1969-64*

**OEM #**

1032473M91

1035836M91,3957981

**CASTING #**

38399175, 3859326

# MASSEY-FERGUSON

**OEM #**

830691M91,  
8530514M91

**CASTING #**

Z129K-402

**7091X**

**4 CYL TRACTOR,  
LOADER, CRAWLER**

*MF135, MF150, MF2135 Gas Models 1970-65  
TO35, F40, H140, F35, MF35, MF50  
Gas Models 1964-55*

*Picture not  
Available  
At this time*

**OEM #**

835615M91

**CASTING #**

Z129K-402

**7092X**

**4 CYL TRACTOR,  
LOADER, CRAWLER**

*MF-180, Gas Models 1970-65  
MF-65 Gas Models w/o Pulley  
1964-58*

*Picture not  
Available  
At this time*

**7400X**

**OEM#**  
904 200 04 01

**MODEL**  
ATEGO OM904

*One  
Hole*

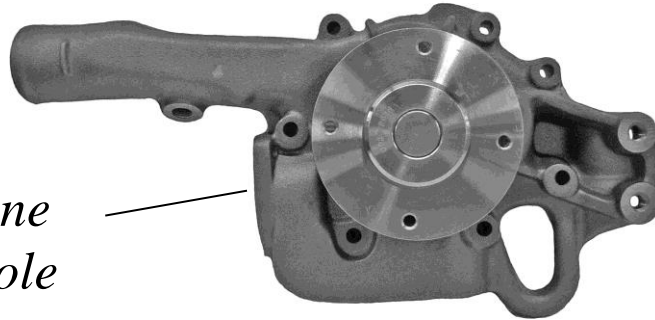

**7401X**

**OEM#**  
906 200 4801  
A906 200 1401  
A906 200 2001

**MODEL**  
U3000, U5000  
OM900, OM906

*Two  
Holes*

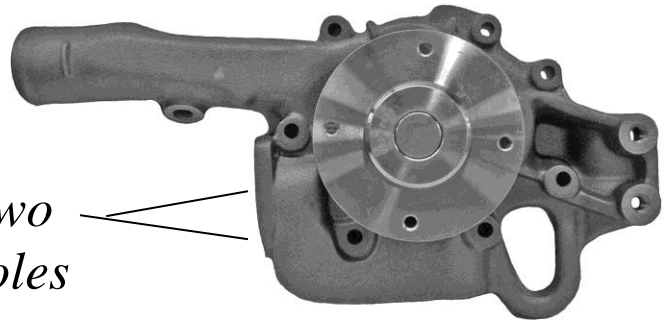

**OEM #**

41312159, 41312487

**CASTING #**

37711330B, 37711331

**7088X**  
**3 CYL ENGINE**

*1969-1965  
Engine AD3-153*



**OEM #**

n/a

**CASTING #**

n/a

**7089X**  
**3 CYL ENGINE**

*1964-1960  
Engines 3A-152*

*Picture not  
Available  
At this time*

**7350X**

**OEM #**  
11-4576

**CASTING #**  
PH374

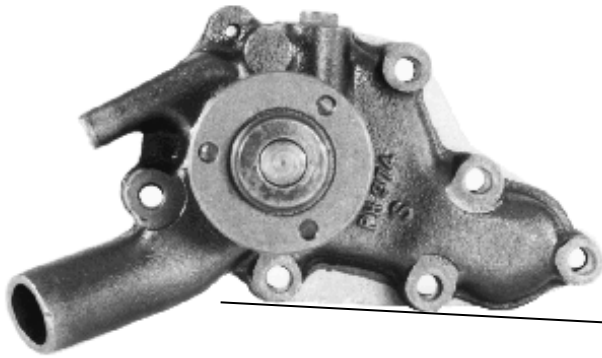

2.2L Direct Injection  
*WITHOUT* Auxiliary Port

**7351X**

**OEM #**  
T-K4576, 11-5858

**CASTING #**  
M1, M2

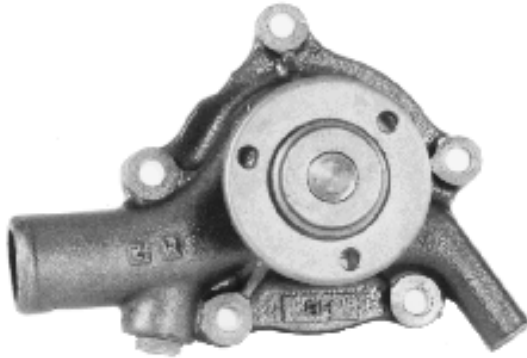

2.2L Direct Injection  
With Auxiliary Port

**7352X**

**OEM #**  
11-5858

**CASTING #**  
M1, M2

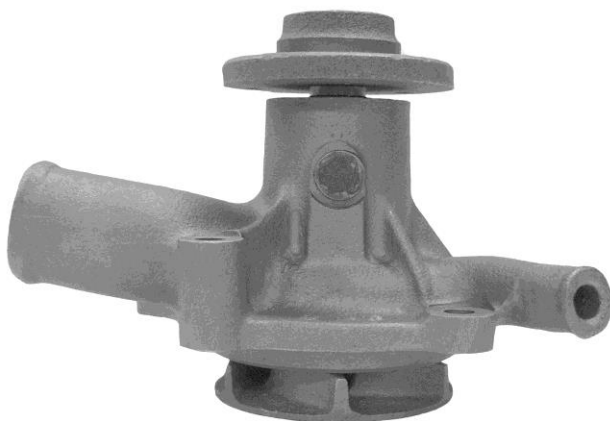

2.2L Direct Injection  
*Without* Auxiliary Port

**7500X**

**OEM #**

20431135, 20713787, 20734268

**CASTING #**

20713184, 8170307



***D12C, V12***  
***2.2L Direct Injection***  
***WITHOUT Auxiliary Port***

<b>MANUFACTURER</b>	<b>APPLICATION/ENGINE</b>	<b>OEM Number</b>	<b>BEPKO PART#</b>
Allis Chalmers	Continental Eng. F163, w/3 Groove Pulley	874617	7033X
Allis Chalmers	Continental Eng. F162, w/2 Groove Pulley	994164	7032X
Allis Chalmers	Continental Eng. F226, F227, F244, F245, w/2 Groove Pulley	994173	7034X
Allis Chalmers	HD-5 Diesel Left Hand	5135595	7103X
Allis Chalmers	HD-7 Diesel Left Hand	5135595	7103X
Allis Chalmers	HD-7 Diesel Left Hand	5135595	7103X
Allis Chalmers	HD-5 Diesel Right Hand	5135596	7104X
Allis Chalmers	HD-7 Diesel Right Hand	5135596	7104X
Case	Model 600 w/G188D Diesel Eng.	A146584	7031X
Case	430, 470, 480, 530, 570, 580B, 630 Tractors w/G188D Diesel Eng.	A146584	7031X
Case	310E, 310F, 310G, 350, 450 Crawler w/G188D Diesel Eng.	A146584	7031X
Case	480C, 580C, 1845 Tractor Loaders w/G188D Diesel Eng.	A146584	7031X
Case	1150, 1155, 1255 Windrowers w/G188D Diesel Eng.	A146584	7031X
Case	Model 150 w/400 Eng.	G-11956	7030X
Case	Model 600 w/G188B Eng.	G-11956	7030X
Case	310D, 310F Utility, 430, 440, 530, 540, 540C, 541, 541C Gas Models	G-11956	7030X
Case	200B, 210B, 300B, 310B, 400B, 500B, 600B, 610B Gas Models	G-11956	7030X
Case	200, 210, 300, 310, 400, 500, 600, 610 Gas Models	G-11956	7030X
Case	300, 320, 350, 351 Gas Models	G-11956	7030X
Case	VA, VAC Series (After No. 72-E07778	G-11956	7030X
Caterpillar	Continental Eng. F163, w/3 Groove Pulley	874617	7033X
Caterpillar	Continental Eng. F162, w/2 Groove Pulley	994164	7032X
Caterpillar	Continental Eng. F226, F227, F244, F245, w/2 Groove Pulley	994173	7034X
Caterpillar	3176B, C10, C12, C13 Acert Cast Iron Housing	1006944	7011X
Caterpillar	3176 Aluminum Casting	1025844	7009X
Caterpillar	C7, 3126 w/Multi Groove Pulley	227-4299	7016MX
Caterpillar	3208, 636 Cu. Inch Eng. w/pulley	0R0781	7002X
Caterpillar		0R0781,	7002X
Caterpillar	3406 B&C, 893 Cu. Inch. Flat Gear w/curved Teeth	1OR0482	7006X
Caterpillar	3406E w/Dome Gear & Curved Teeth	1OR0483	7006EX
Caterpillar	3406E, C15, C16 w/Straight Tooth Dome Gear	1OR0484	7006EGX
Caterpillar	C17, C18 Acert, C27, Reminds you of 7006EG except Larger Housing, w/Straight Teeth Dome Gear	1OR-3326	7017X
Caterpillar	C17, C18 Acert, C27, Reminds you of 7006EG except Larger Housing, w/Straight Teeth Dome Gear	246-3132	7017X
Caterpillar	C17, C18 Acert, C27, Reminds you of 7006EG except Larger Housing, w/Straight Teeth Dome Gear	280-7374	7017X
Caterpillar	3208, 636 Cu. Inch Eng. w/pulley	2W1225	7002X
Caterpillar	3208, 636 Cu. Inch Eng. Threaded Pulley for Fan Clutch.	2W1227	7004X
Caterpillar	C17, C18 Acert, C27, Reminds you of 7006EG except Larger Housing, w/Straight Teeth Dome Gear	314-5155	7017X
Caterpillar	3116 w/4 3/8" Pulley	4P3683	7012X
Caterpillar	3116 w/Fittings	4P3683,	7012KX
Caterpillar	3306 Straight Teeth w/Off Set Holes	4P9862,	7007GX
Caterpillar	3116 w/4 3/8" Pulley	4W0253,	7012X



Caterpillar	3116 w/Fittings	4W0253,	7012KX
Caterpillar	3406E w/Dome Gear & Curved Teeth	613890-OR4120,	7006EX
Caterpillar	3406E w/Dome Gear & Curved Teeth	613890-OR8218E	7006EX
Caterpillar	3306 Angled Teeth w/Off Set Holes & 3 1/8" Bearing	6N8413, OR1251	7007X
Caterpillar	3406 B&C, 893 Cu. Inch. Flat Gear w/curved Teeth	7C4957	7006X
Caterpillar	3406 & 3406E Back Plate Kit	7C9222	7006BPX
Caterpillar	3176 Aluminum Casting	7E8554,	7009X
Caterpillar	3304 w/Straight Holes & 2 11/16" Bearing	7N5909	7010X
Caterpillar	3406 B&C, 893 Cu. Inch. Flat Gear w/curved Teeth	7W7019	7006X
Caterpillar	1140 &1160, Models: 1500, 1800 w/3150 eng.	9L7660	7005X
Caterpillar	3208, 636 Cu. Inch Eng. With No Pulley	9N6147	7001X
Caterpillar		9N6147	7002X
Caterpillar	3208, 636 Cu. Inch Eng. w/pulley	9N6147	7002X
Caterpillar	3176 Aluminum Casting	9Y4361	7009X
Caterpillar	3116 w/4 3/8" Pulley	9Y4879,	7012X
Caterpillar	3116 w/Fittings	9Y4879,	7012KX
Caterpillar	3116 w/3 3/4" Pulley	N/A	7015X
Caterpillar	Similar to 7016M Except has Hub	N/A	7016X
Caterpillar	1140 &1160, Models: 1500, 1800 w/3150 eng.	OR0644	7005X
Caterpillar	3176B, C10, C12, C13 Acert Cast Iron Housing	OR0705,	7011X
Caterpillar	3208 w/press on pulley	OR0781	7008X
Caterpillar	3306 w/Solid Gear & 2 11/16" Bearing Similar to 7007 <b>Straight Teeth</b>	OR1002 <b>OR1002</b>	7014X <b>7014GX</b>
Caterpillar	3306 Reminds you of 7007 Except has 2 3/8" Bearing	OR1003	7013X
Caterpillar	3116 w/Fittings	OR1013	7012KX
Caterpillar	3116 w/4 3/8" Pulley	OR1013	7012X
Caterpillar	3116 w/Fittings	OR3007	7012KX
Caterpillar	3116 w/4 3/8" Pulley	OR3007	7012X
Caterpillar	3176B, C10, C12, C13 Acert Cast Iron Housing	OR3709	7011X
Caterpillar	3176 Aluminum Casting	OR4117	7009X
Caterpillar	3406 B&C, 893 Cu. Inch. Flat Gear w/curved Teeth	OR8217	7006X
Caterpillar	3306 Straight Teeth w/Off Set Holes	OR8532	7007GX
Caterpillar	3176 Aluminum Casting	OR8766,	7009X
Caterpillar	3176B, C10, C12, C13 Acert Cast Iron Housing	OR8767	7011X
Caterpillar	3306 Straight Teeth w/Off Set Holes	OR9493	7007GX
Caterpillar	3306 Reminds you of 7007 Except has 2 3/8" Bearing	OR9497	7013X
Caterpillar	3306 w/Solid Gear & 2 11/16" Bearing Similar to 7007	OR9785	7014X
Caterpillar	3406E, C15, C16 w/Straight Tooth Dome Gear	OR9869	7006EGX
Caterpillar	3306, 40LH Tooth Gear	OR2853, 2W8003	7021X
Caterpillar	3116/3126 Engine		<a href="#">7019X</a>
Chevrolet Truck	4.8L (292), Series 50, 60, 2nd Design	357262	<a href="#">7143X</a>
Chevrolet Truck	4.8L (292), Series 50, 60	474056	<a href="#">7143X</a>
Chevrolet Truck	4.8L (292), Series 50, 60, School Bus	474056	<a href="#">7143X</a>
Chevrolet Truck	8.1L, C6, C7, Kodiak, B7 School Bus	1255863	<a href="#">7144X</a>
Chevrolet Truck	Titan 90 Series w/54 BBC 6V-92T, 6V-92TT, 8V-92T Diesel Eng. Left Hand Mount	5135595	7103X
Chevrolet Truck	Series 50, 60, 65 w/6-71 Diesel Eng. Left Hand Mount	5135595	7103X
Chevrolet Truck	Titan 90 Series w/54 BBC 6-71 Diesel Eng. Right Hand Mount	5135596	7104X
Chevrolet Truck	Series 50, 60, 65 w/6-71 Diesel Eng. Right Hand Mount	5135596	7104X

Chevrolet Truck	Series 90 w/6-71 Diesel Eng.	5135596	7104X
Chevrolet Truck	6.5L (395), B7 School Bus	5744662	7129X
Chevrolet Truck	5.7L (350), Series 40, 50, 60	6258551	7146X
Chevrolet Truck	5.7L (350), Series 40, 50, 60	10048921	7146X
Chevrolet Truck	6.0L (366), 7.0L (427) School Bus, 60, 70 Series w/Screw on Hub	10074182	7116X
Chevrolet Truck	7.4L (454), Series 60, 70	10074182	7116X
Chevrolet Truck	4.8L (292), P4 Series	10112691	7143X
Chevrolet Truck	6.0L (366), 7.0L (427) B7 School Bus, C5, C6, C7 Series w/Screw on Hub	10140667	7123X
Chevrolet Truck	6.0L (366), F6, 7 Series w/Screw on Hub	10140667	7123X
Chevrolet Truck	6.0L (366), 7.0L (427) P6 School Bus, 50, 60, 70 Series w/Screw on Hub	10140667	7123X
Chevrolet Truck	7.4L, B7 School Bus, Kodiak C6, C7, (w/Threaded Hub & Bypass Tube)	12456328	7145X
Chevrolet Truck	6.0L (366), 7.0L (427) B7 School Bus, C5, C6, C7 Series w/Screw on Hub	12529192	7123X
Chevrolet Truck	6.5L (395), B7 School Bus	12534772	7129X
Chevrolet Truck	6.5L (395), B7 School Bus, Exc. Hazard Warning Switch	12534772	7129X
Chevrolet Truck	8.1L, Kodiak C4500, C5500, C6500, C7500, C8500	88893907	7144X
Chevrolet Truck	8.1L, C6, C7, Kodiak, B7 School Bus	88893907	7144X
Clark Truck & Tractor, (4Cyl.)	Continental Series Y400 Engine Pump w/Back Plate and 2 Groove Pulley	865707	7036X
Clark Truck & Tractor, (4Cyl.)	Continental Series F162 Engine Pump w/Back Plate and 2 Groove Pulley	865774	7035X
Clark Truck & Tractor, (4Cyl.)	Continental Series Y400 Engine Pump w/Back Plate and 2 Groove Pulley	Y400K-3612	7036X
Clark Truck & Tractor, (4Cyl.)	Continental Series F162 Engine Pump w/Back Plate and 2 Groove Pulley	F162K-3653	7035X
Continental Motors, (4Cyl.)	Series F162 Pump Using F400K-422 Body, w/Back Plate and 2 Groove Pulley HD206K-305	F162K-3653	7035X
Continental Motors, (4Cyl.)	Series Y400 Pump Using Y400K-410 Body, w/Back Plate and 2 Groove Pulley Y91K-336	Y400K-3612	7036X
Cummins Diesel	NTC Formula 230 (Short Suitcase w/2 Groove Pulley & 4" Impeller)	302247	7057X
Cummins Diesel	Dina w/Rear engine 155 6cyl & 210 8cyl	377411	7045X
Cummins Diesel	NTC270-CT, NT855-C280, NTC290, NTC290-R, NTC855-C310, NT310, NTC350, NTA855-C360	3000886	7051X
Cummins Diesel	B Series, 3.9L 4cyl, 5.9L 6cyl. Old Style Pulley w/lip	3003731	7063AX
Cummins Diesel	NTC300, 350, 400: Formula 300, 350, 400, 475 (Suitcase Pump) w/4 11/16" Multi Groove Pulley & 4" Impeller	3004923	7061X
Cummins Diesel	Big Cam	3007290	7044X
Cummins Diesel	Cummins 4000 (14.0)	3007290	7044X
Cummins Diesel	NTC290, NTC350, NTC400, Formula 290, 350 (Suitcase Pump) w/4 11/16" Multi Groove Pulley & 4 1/2" Impeller, Vented	3022474	7052X
Cummins Diesel	KT/KTA 1150	3022920	7040X
Cummins Diesel	Small Cam FFC, w/4 11/16" Multi Groove Pulley & 4" Impeller	3024671	7049X
Cummins Diesel	Ford LTL9000, GMC Brigadier (Suitcase Pump) (5 1/2 Bore) (Not Suitable for Horizontal Eng.) w/4 11/16" Multi Groove Pulley & 4 1/2" Impeller, Vented	3027174	7075X
Cummins Diesel	NTC Formula 230, (Short Suitcase w/4 11/16" Multi Groove Pulley & 4 1/2" Impeller)	3027882	7062X

Cummins Diesel	Multi Groove Idler Pulley	3034969	7067X
Cummins Diesel	Small Cam w/2 Groove Pulley & 4 1/2" Impeller	3045161	7050X
Cummins Diesel	4 11/16" Multi Groove Pulley & 4 1/2" Impeller	3051368	7041X
Cummins Diesel	Big Cam, 4 11/16" Pulley & 4 1/2" Impeller, w/7 Hole Casting, Can use 7052	3051378	7042X
Cummins Diesel	NTC-300, 315, 350, 365, 400, w/Multi Groove Pulley	3052836	7060X
Cummins Diesel	Multi Groove Idler Pulley	3062602	7067X
Cummins Diesel	NTC-300, 315, 350, 365, 400, Idler w/Multi Groove Pulley	3062930	7069X
Cummins Diesel	NTC-300, 315, 350, 365, 400, Idler w/Multi Groove Pulley & Bracket	3062930	7074X
Cummins Diesel	NTC-300, 315, 350, 365, 400, Idler w/Multi Groove Pulley	3062931	7069X
Cummins Diesel	Big Cam, Multi Groove Idler Pulley	3064919	7059X
Cummins Diesel	2 Groove Idler Pulley	3064920	7058X
Cummins Diesel	NTC-300, 315, 350, 365, 400, Idler w/Stamped Pulley	3065000	7071X
Cummins Diesel	N14 Idler Pulley	3066330	7073X
Cummins Diesel	B Series, ISB, 3.9L 4cyl, 5.9L 6cyl. New Style Pulley w/out lip	3286278	7063X
Cummins Diesel	In-Line 6 Cyl.	3286293	7076X
Cummins Diesel	ISC & ISL series, Similar to 7076 except has Larger Casting at Mount w/Larger Impeller.	3286293	7082X
Cummins Diesel	ISX eng. Has 10 Groove Pulley at Top Step	3800495	7083X
Cummins Diesel	ISX eng. Has 12 Groove Pulley at Top Step	3800495	7084X
Cummins Diesel	ISM, M11 w/3 Hole Mount, Short Shaft	3800745	7072SSX
Cummins Diesel	8.3L, Long Noise	3800974	7076LX
Cummins Diesel	8.3L, Long Noise	3800976	7076LX
Cummins Diesel	NTC-300, 315, 350, 365, 400, Idler w/Multi Groove Pulley	3801234	7069X
Cummins Diesel	300, 350, 400, Fleet 300, NTC-Formula 300, 350 400 (w/4 1/2" Multi Groove Pulley & 4 1/2" Impeller) Vented	3801708	7064X
Cummins Diesel	NTC270-CT, NT855-C280, NTC290, NTC290-R, NTC855-C310, NT310, NTC350, NTA855-C360	3801784	7051X
Cummins Diesel	NTC290, NTC350, NTC400, Formula 290, 350 (Suitcase Pump) w/4 11/16" Multi Groove Pulley & 4 1/2" Impeller, Vented	3801788	7052X
Cummins Diesel	LTA10, 240, 270, 300, w/4 hole Mount up to 1991	3801840	7066X
Cummins Diesel	B Series, 3.9L 4cyl, 5.9L 6cyl. Old Style Pulley w/lip	3802004	7063AX
Cummins Diesel	In-Line 6 Cyl.	3802081	7076X
Cummins Diesel	B Series, ISB, 3.9L 4cyl, 5.9L 6cyl. New Style Pulley w/out lip	3802358	7063X
Cummins Diesel	B Series, ISB, 3.9L 4cyl, 5.9L 6cyl. New Style Pulley w/out lip	3802970	7063X
Cummins Diesel	B Series, ISB, 3.9L 4cyl, 5.9L 6cyl. New Style Pulley w/out lip	3802971	7063X
Cummins Diesel	NTC-300, 315, 350, 365, 400, w/Multi Groove Pulley	3803030	7060X
Cummins Diesel	NTC-300, 315, 350, 365, 400, w/Multi Groove Pulley	3803138	7060X
Cummins Diesel	310, 330, 350, 370, 410 w/Multi Groove Pulley	3803361	7068X
Cummins Diesel	LTA10, 240, 270, 300, w/4 hole Mount up to 1991	3803402	7066X
Cummins Diesel	L-10E-MTA 11-330E w/3 Hole Mount, Long Shaft	3803403	7072X
Cummins Diesel	310, 330, 350, 370, 410 w/Multi Groove Pulley	3803605	7068X
Cummins Diesel	N14 - Volvo	3804826	7081X
Cummins Diesel	ISC & ISL series, Similar to 7076 except has Larger Casting at Mount w/Larger Impeller.	3804927	7082X

Cummins Diesel	B Series, ISB, 3.9L 4cyl, 5.9L 6cyl. New Style Pulley w/out lip	3903749	7063X
Cummins Diesel	B Series, ISB, 3.9L 4cyl, 5.9L 6cyl. New Style Pulley w/out lip	3913432	7063X
Cummins Diesel	ISC & ISL series, Similar to 7076 except has Larger Casting at Mount w/Larger Impeller.	3940052	7082X
Cummins Diesel	ISC & ISL series, Similar to 7076 except has Larger Casting at Mount w/Larger Impeller.	3973114	7082X
Cummins Diesel	ISX eng. Has 10 Groove Pulley at Top Step	4089908	7083X
Cummins Diesel	300, 350, 400, Fleet 300, NTC-Formula 300, 350 400 (w/4 1/2" Multi Groove Pulley & 4 1/2" Impeller) Vented	3045943RX	7064X
Cummins Diesel	NTC270-CT, NT855-C280, NTC290, NTC290-R, NTC855-C310, NT310, NTC350, NTA855-C360	AR8855	7051X
Cummins Diesel	Dina w/Rear engine 155 6cyl & 210 8cyl	14079-D105	7045X
Cummins Diesel	NTC-300, 315, 350, 365, 400, w/Multi Groove Pulley	3062928,	7060X
Cummins Diesel	Dina w/Rear engine 155 6cyl & 210 8cyl	34079-B105	7045X
Cummins Diesel	ISM, M11 w/3 Hole Mount, Short Shaft	3800745-RX,	7072SSX
Cummins Diesel	In-Line 6 Cyl.	3804883RX	7076X
Cummins Diesel	ISX eng. Has 10 Groove Pulley at Top Step	4089158RX	7083X
Cummins Diesel	ISC & ISL series, Similar to 7076 except has Larger Casting at Mount w/Larger Impeller.	4089647NX	7082X
Cummins Diesel	ISM, M11 w/3 Hole Mount, Short Shaft	4955708NX	7072SSX
Cummins Diesel	Dina w/front engine 155 6cyl & 210 8cyl	A-34079-A05	7043X
Cummins Diesel	4 11/16" Multi Groove Pulley & 4 1/2" Impeller	AR10961	7041X
Cummins Diesel	V/VT/VTA 1710	AR-11229RX	7078X
Cummins Diesel	NH, NT & NTC Non FCC, NH230, NH250, NHC270, NHE225 Diesel, NT280, NT300 , NT310, NT335, NT380, NTA380, NTC335, NTC350, NTC380, (Non FCC) w/out Pulley	AR4283	7065X
Cummins Diesel	NH, NT & NTC Non FCC, NH230, NH250, NHC270, NHE225 Diesel, NT280, NT300 , NT310, NT335, NT380, NTA380, NTC335, NTC350, NTC380, (Non FCC) w/2 belt Pulley	AR4284	7053X
Cummins Diesel	NTC Formula 230 (Short Suitcase w/2 Groove Pulley & 4" Impeller)	AR45073	7057X
Cummins Diesel	NTC270-CT, NT855-C280, NTC290, NTC290-R, NTC855-C310, NT310, NTC350, NTA855-C360	AR45090	7051X
Cummins Diesel	NTC290, NTC350, NTC400, Formula 290, 350 (Suitcase Pump) w/4 11/16" Multi Groove Pulley & 4 1/2" Impeller, Vented	AR45184	7052X
Cummins Diesel	Big Cam, Multi Groove Idler Pulley	AR45189	7059X
Cummins Diesel	NT & NTC 250 5 1/2" Bore & 9 1/4" Shaft	AR4547	7054X
Cummins Diesel	NT & NTC 250 5 1/2" Bore & 9 7/8" Shaft	AR4548	7055X
Cummins Diesel	NH 250 Military (5 1/2" Bore Shaft) w/pulley	AR51360	7080X
Cummins Diesel	w/3 Belt Pulley	AR5664	7056X
Cummins Diesel	V, VT 555, V8	AR61116	7070X
Cummins Diesel	Dina w/front engine 155 6cyl & 210 8cyl	AR61788	7043X
Cummins Diesel	Dina w/Rear engine 155 6cyl & 210 8cyl	AR-61789	7045X
Cummins Diesel	2 Groove Idler Pulley	AR8851	7058X
Cummins Diesel	w/3 Belt Pulley	AR9931	7056X
Cummins Diesel	220, NHT, NHR5, w/5 1/8" Bore	BM50345, BM50356	7047X
Cummins Diesel	H, HF, HR, HRS, NFT, NRT, NRTO, NH220, NHE180, NHE195, NHE220, NHS, NHR5 (w/High Mounted Fan) (w/out Pulley) ( Right Hand Mounted Pump)	BM50466	7077X

Cummins Diesel	H, HF, HR, HRS, NFT, NRT, NRTO, NH220, NHE180, NHE195, NHE220, NHS, NHRS (w/Pulley) ( Right Hand Mounted Pump)	BM54327	7077PX
Cummins Diesel	220, NRT, NROT, w/5 1/8" Bore	BM71040	7048X
Cummins Diesel	H, HF, HR, HRS, NFT, NRT, NRTO, NH220, NHE180, NHE195, NHE220, NHS, NHRS (w/High Mounted Fan) (w/out Pulley) ( Right Hand Mounted Pump)	BM76506	7077X
Cummins Diesel	In-Line 6 Cyl.	F3HZ8501B,	7076X
Cummins Diesel	220, Smaller top Bearing w/Snap Ring in Second Slot	N/A	7047SX
Cummins Diesel	KT/KTA 1710, 2300	N/A	7079X
Detroit Diesel	3, 4, 6 Cyl. In Line Eng. (Exc. Turbo) (Left Hand Pump)	5135595	7103X
Detroit Diesel	3, 4, 6 Cyl. In Line Eng. (Exc. Turbo) (Right Hand Pump)	5135596	7104X
Detroit Diesel	Left Hand	5144685	7101X
Detroit Diesel	Right Hand	5144687	7102X
Detroit Diesel	V-6 & V-8 Engines, Walking Pump w/1 Outlet pointing straight down & 1 Outlet at 45 Degree Angle, w/Bolt on Back Cover	5149320	7111X
Detroit Diesel	Standing, w/bolt on Back Cover & w/Heater Provision	5149321	7112X
Detroit Diesel	V-6 & V-8 Engines, Turbo, Standing Pump w/2 Outlets pointing straight Down, High Capacity (w/Bolt on Back Cover)	5149326	7107X
Detroit Diesel	V-8 Engines, Turbo, Running Pump w/2 Outlets at 45 Degree Angles in Opposite Directions, High Capacity (w/Bolt on Back Cover)	5149327	7108X
Detroit Diesel	V-6 & V-8 Engines, Non Turbo, Standing Pump w/2 Outlets pointing straight Down, Standard Capacity (w/Bolt on Back Cover)	5149328	7105X
Detroit Diesel	V-6 & V-8 Engines, Non Turbo, Running Pump w/2 Outlets at 45 Degree Angles in Opposite Directions, Standard Capacity (w/ Bolt on Back Cover)	5149329	7106X
Detroit Diesel	V-8 Engines, Turbo, Running Pump w/2 Outlets at 45 Degree Angles in Opposite Directions, High Capacity (w/Reverse Gear & Bolt on Back Cover)	5149381	7115X
Detroit Diesel	V-8 Engines, Turbo, Standing Pump w/2 Outlets pointing straight Down, High Capacity (w/Reverse Gear & Bolt on Back Cover)	5149382	7118X
Detroit Diesel	3, 4, 6 Cyl. In Line Eng. (Exc. Turbo) (Left Hand Pump)	5149706	7103X
Detroit Diesel	3, 4, 6 Cyl. In Line Eng. (Exc. Turbo) (Right Hand Pump)	5149707	7104X
Detroit Diesel	In-Line A & B Eng. Turbo (Right Hand) High Capacity	5149708	7114X
Detroit Diesel	In-Line A & B Eng. Turbo (Left Hand) High Capacity	5149710	7113X
Detroit Diesel	3, 4, 6 Cyl. In Line Eng. (Exc. Turbo) (Right Hand Pump)	5178318	7104X
Detroit Diesel	Right Hand	5178658	7102X
Detroit Diesel	V-6 & V-8 Engines, Running Pump w/2 Outlets at 45 Degree Angles in Opposite Directions, w/Snap Ring Back Cover	8921104	7110X
Detroit Diesel	V-6 & V-8 Engines, Walking Pump w/1 Outlet pointing straight down & 1 Outlet at 45 Degree Angle, w/Snap Ring Back Cover	8921105	7109X
Detroit Diesel	8 Cyl. Diesel, w/Out Heater Outlet Provision	8922302	7119X

Detroit Diesel	V-6 & V-8 Engines, Running Pump w/2 Outlets at 45 Degree Angles in Opposite Directions, w/Snap Ring Back Cover	8922335	7110X
Detroit Diesel	V-6 & V-8 Engines, Walking Pump w/1 Outlet pointing straight down & 1 Outlet at 45 Degree Angle, w/Snap Ring Back Cover	8922336	7109X
Detroit Diesel	8 Cyl. Diesel, w/Heater Outlet Provision	8928672	7120X
Detroit Diesel	V-6 & V-8 Engines, Non Turbo, Standing Pump w/2 Outlets pointing straight Down, Standard Capacity (w/Bolt on Back Cover)	23501938	7105X
Detroit Diesel	V-6 & V-8 Engines, Non Turbo, Running Pump w/2 Outlets at 45 Degree Angles in Opposite Directions, Standard Capacity (w/ Bolt on Back Cover)	23501939	7106X
Detroit Diesel		23501947	7125X
Detroit Diesel	Front Mount, Before 12/90	23505019	7121X
Detroit Diesel	Rear Mount, After 12/90 (w/ 1/4" Pipe Port)	23505895	7122X
Detroit Diesel	Left Hand	23506003	7101X
Detroit Diesel	Right Hand	23506007	7102X
Detroit Diesel	In-Line A & B Engs. Turbo (Left Hand) High Capacity	23506204	7113X
Detroit Diesel	V-6 & V-8 Engines, Walking Pump w/1 Outlet pointing straight down & 1 Outlet at 45 Degree Angle, w/Snap Ring Back Cover	23506602	7109X
Detroit Diesel	V-6 & V-8 Engines, Walking Pump w/1 Outlet pointing straight down & 1 Outlet at 45 Degree Angle, w/Snap Ring Back Cover & Reverse Gear	23506604	7124X
Detroit Diesel	V-6 & V-8 Engines, Running Pump w/2 Outlets at 45 Degree Angles in Opposite Directions, w/Snap Ring Back Cover	23506623	7110X
Detroit Diesel	V-8 Engines, Turbo, Standing Pump w/2 Outlets pointing straight Down, High Capacity (w/Reverse Gear & Bolt on Back Cover)	23506670	7118X
Detroit Diesel	V-8 Engines, Turbo, Running Pump w/2 Outlets at 45 Degree Angles in Opposite Directions, High Capacity (w/Reverse Gear & Bolt on Back Cover)	23506698	7115X
Detroit Diesel	In-Line A & B Engs. Turbo (Right Hand) High Capacity	23506711	7114X
Detroit Diesel	3, 4, 6 Cyl. In Line Engs. (Exc. Turbo) (Left Hand Pump)	23506723	7103X
Detroit Diesel	3, 4, 6 Cyl. In Line Engs. (Exc. Turbo) (Right Hand Pump)	23506735	7104X
Detroit Diesel	Standing, w/bolt on Back Cover & w/Heater Provision	23506763	7112X
Detroit Diesel	V-6 & V-8 Engines, Turbo, Standing Pump w/2 Outlets pointing straight Down, High Capacity (w/Bolt on Back Cover)	23506790	7107X
Detroit Diesel	V-8 Engines, Turbo, Running Pump w/2 Outlets at 45 Degree Angles in Opposite Directions, High Capacity (w/Bolt on Back Cover)	23506791	7108X
Detroit Diesel	Front Mount, Before 12/90	23509067	7121X
Detroit Diesel	w/6 Vane Impeller, High Capacity (3/8" Pipe Port) w/Steel Back Plate	23522707	7126SX
Detroit Diesel	w/6 Vane Impeller, High Capacity (3/8" Pipe Port)	23522707	7126X
Detroit Diesel	w/6 Vane Impeller, High Capacity, Kangaroo Pouch.	23526039	7127X
Detroit Diesel	EGR, 14L	23531258	7142X
Detroit Diesel	EGR, 14L	R23531245	7141X
Detroit Diesel	Rear Mount, After 12/90 (w/ 1/4" Pipe Port)	R3505895	7122X
Detroit Diesel	Front Mount, Before 12/90	R23514989	7121X
Detroit Diesel	Rear Mount, After 12/90 (w/ 1/4" Pipe Port)	R3520136	7122X

Detroit Diesel Accessory Drives	60 Series, Accessory Drive, w/2 Belt Pulley	23509200	9160X
Detroit Diesel Accessory Drives	60 Series, Accessory Drive, w/out Pulley	23509200	9162X
Detroit Diesel Accessory Drives	60 Series, Accessory Drive, w/Multi Groove Pulley	23509201	9161X
Dodge Trucks	2.8L (170), 3.7L (225)	2196910	7086X
Dodge Trucks	2.8L (170), 3.2L (198) 3.7L (225)	2196910	7086X
Dodge Trucks	3.7L (225)	2196910	7086X
Dodge Trucks	2.8L (170), 3.2L (198) 3.7L (225)	2808679	7086X
Dodge Trucks	3.2L (198) 3.7L (225)	2808679	7086X
Dodge Trucks	2.8L (170), 3.2L (198) 3.7L (225)	2808679	7086X
Dodge Trucks	3.7L (225)	2808679	7086X
Dodge Trucks	3.7L (225)	2808679	7086X
Dodge Trucks	2.8L (170), 3.7L (225)	3420050	7086X
Dodge Trucks	2.8L (170), 3.2L (198) 3.7L (225)	3420050	7086X
Dodge Trucks	3.7L (225)	3420050	7086X
Dodge Trucks	3.7L (225)	3420050	7086X
Dodge Trucks	3.2L (198) 3.7L (225)	4106034	7086X
Dodge Trucks	2.8L (170), 3.2L (198) 3.7L (225)	4106034	7086X
Dodge Trucks	3.7L (225)	4106034	7086X
Dodge Trucks	3.2L (198) 3.7L (225)	4131243	7086X
Dodge Trucks	2.8L (170), 3.2L (198) 3.7L (225)	4131243	7086X
Dodge Trucks	3.7L (225)	4131243	7086X
Dodge Trucks	5.9L (360) Cummins Turbo Diesel	4429404	7063X
Dodge Trucks	5.9L (360) Cummins Turbo Diesel	4429404	7063X
Dodge Trucks	5.9L (360) Cummins Turbo Diesel	4723690	7063X
Dodge Trucks	5.9L (360) Cummins Turbo Diesel	4723690	7063X
Dodge Trucks	3.9L (239)	53020280	7087X
Dodge Trucks	5.2L (318), 5.9L (360)	53020280	7087X
Dodge Trucks	3.9L (239)	53020280	7087X
Dodge Trucks	5.2L (318), 5.9L (360)	53020280	7087X
Dodge Trucks	5.2L (318), 5.9L (360)	53021018	7087X
Dodge Trucks	3.9L (239)	53021018	7087X
Dodge Trucks	5.2L (318), 5.9L (360)	53021018	7087X
Dodge Trucks	5.9L (360) Cummins Turbo Diesel	3286278RX	7063X
Dodge Trucks	3.2L (198) 3.7L (225)	3420050,	7086X
Dodge Trucks	5.9L (360) Cummins Turbo Diesel	5010964AA	7063X
Dodge Trucks	5.9L (360) Cummins Turbo Diesel	5010964AB	7063X
Dodge Trucks	2.7L 2500, 3500	5138057AA	7085X
Dodge Trucks	3.9L (239)	53021018,	7087X
Dodge Trucks	3.9L (239)	53021018AB	7087X
Dodge Trucks	3.9L (239)	53021018AB	7087X
Dodge Trucks	3.9L (239)	53021018AB	7087X
Dodge Trucks	5.2L (318), 5.9L (360)	53021018AB,	7087X
Dodge Trucks	5.2L (318), 5.9L (360)	53021018AB,	7087X
Dodge Trucks	3.9L (239)	53021018AC	7087X
Ford Tractor & Industrial	Model 2N, 8N, 9N	8N-8501	7335X
Ford Tractor & Industrial	All 2000 thru 7000 Series Gas or Diesel (w/Single Groove Pulley & 4.100" Impeller)	D5NN-8501E	7330X
Ford Tractor & Industrial	9000, 9200	DHPN-8A513B	7337X
Ford Tractor & Industrial	Series 800D, 801D, 900D, 901D, 1800, 4030D, 4031D, 4040D, 4110D, 4120D, 4121D, 4130D, 4131D, 4140D w/D172 Diesel	EAF-8501C	7334X
Ford Tractor & Industrial	Series 800, 801, 900, 901, 1800, 1801, 4030, 4031, 4040, 4110, 4121, 4130, 4131, 4140 w/172 Gas or L.P.G	EAF-8501C	7334X



Ford Tractor & Industrial	Model 2N, 8N, 9N	2N-8501	7335X
Ford Tractor & Industrial	Model 2N, 8N, 9N	9N-8501	7335X
Ford Tractor & Industrial	2000, 3000, 4000 Series Gas or Diesel (w/Single Groove Pulley & 3.500 Dia. Impeller)	C5NN-8501A	7331X
Ford Tractor & Industrial	5000 Gas or Diesel (w/Single Groove Pulley & 3.500 Dia. Impeller) (Can Use 7330X)	C5NN-8501A	7331X
Ford Tractor & Industrial	All 2000 thru 7000 Series Gas or Diesel (w/Single Groove Pulley & 4.100" Impeller)	C5NN-8501E	7330X
Ford Tractor & Industrial	8000, 8200, 8400	C9NN-8501B	7337X
Ford Tractor & Industrial	9000, 9200	C9NN-8501B	7337X
Ford Tractor & Industrial	NAA, Major	CDPN-8501B	7338X
Ford Tractor & Industrial	134, 172 Tractor & Industrial gas Models 600, 700, 800, 900, 2000, 4000 Series Diesel Models	CDPN-8501C	7334X
Ford Tractor & Industrial	Series 500D, 501D, After Serial #153775; 600D, 601D, 700D, 701D, 2030D, 2031D, 2110D, 2111D, 2120D, 2130D, 2131D w/144 Diesel	CDPN-8501C	7334X
Ford Tractor & Industrial	Series 800D, 801D, 900D, 901D, 1800, 4030D, 4031D, 4040D, 4110D, 4120D, 4121D, 4130D, 4131D, 4140D w/D172 Diesel	CDPN-8501C	7334X
Ford Tractor & Industrial	Series 800, 801, 900, 901, 1800, 1801, 4030, 4031, 4040, 4110, 4121, 4130, 4131, 4140 w/172 Gas or L.P.G	CDPN-8501C	7334X
Ford Tractor & Industrial	Series NAA, 501, 541, 600, 601, 611, 620, 621, 630, 631, 640, 641, 650, 651, 660, 661, 671, 700, 701, 740, 741, 771, 2030, 2031, 2110, 2111, 2120, 2130, 2131 w/134 Gas or L.P.G.	CDPN-8501C	7334X
Ford Tractor & Industrial	Series NAA, 600, 620, 621, 630, 631, 640, 641, 650, 651, 660, 661, 700, 740, 741 w/134 Kerosene Eng.	CDPN-8501C	7334X
Ford Tractor & Industrial	800K, 900K w/172 Kerosene Eng.	CDPN-8501C	7334X
Ford Tractor & Industrial	134, 172, 192 Gas or Diesel	D1JJ-8501C	7332X
Ford Tractor & Industrial	2000, 3000, 4000 Series Gas or Diesel (w/Single Groove Pulley & 3.500 Dia. Impeller)	D5NE-8501A	7331X
Ford Tractor & Industrial	5000 Gas or Diesel (w/Single Groove Pulley & 3.500 Dia. Impeller) (Can Use 7330X)	D5NE-8501A	7331X
Ford Tractor & Industrial	All 2000 thru 7000 Series Gas or Diesel (w/Single Groove Pulley & 4.100" Impeller)	D5NN-8501E	7330X
Ford Tractor & Industrial	8000, 8200, 8400	DHPN-8A513B	7337X
Ford Tractor & Industrial	134, 172 Tractor & Industrial gas Models 600, 700, 800, 900, 2000, 4000 Series Diesel Models	EAF-8501C	7334X
Ford Tractor & Industrial	Series 500D, 501D, After Serial #153775; 600D, 601D, 700D, 701D, 2030D, 2031D, 2110D, 2111D, 2120D, 2130D, 2131D w/144 Diesel	EAF-8501C	7334X
Ford Tractor & Industrial	Series NAA, 501, 541, 600, 601, 611, 620, 621, 630, 631, 640, 641, 650, 651, 660, 661, 671, 700, 701, 740, 741, 771, 2030, 2031, 2110, 2111, 2120, 2130, 2131 w/134 Gas or L.P.G.	EAF-8501C	7334X
Ford Tractor & Industrial	Series NAA, 600, 620, 621, 630, 631, 640, 641, 650, 651, 660, 661, 700, 740, 741 w/134 Kerosene Eng.	EAF-8501C	7334X
Ford Tractor & Industrial	800K, 900K w/172 Kerosene Eng.	EAF-8501C	7334X
Ford Tractor & Industrial	2000, 3000, 4000, 5000, 7000 (2600, 3600, 4100, 4600, 5600, 5700, 6600, 6700, 7600, 7700 (2310, 2610, 2810, 2910, 3610, 3910, 4110, 4610 All 2/90) w/5/16" & 7/16" Mounting Holes (2 Groove Pulley) (Large Bearing)	EAPN-8A513A	7340X



Ford Tractor & Industrial	2000, 3000, 4000, 5000, 7000 (2600, 3600, 4100, 4600, 5600, 5700, 6600, 6700, 7600, 7700 (2310, 2610, 2810, 2910, 3610, 3910, 4110, 4610 All 2/90) w/5/16" & 7/16" Mounting Holes (2 Groove Pulley) (Large Bearing)	EGPN-8A513CA	7340X
Ford Tractor & Industrial	4.9L (300) Industrial Eng.	F6JE-8501BA	7336X
Ford Tractor & Industrial	Models (5110, 5610, 6610, 6810, 7410, 7610, 7710 All 11/88 & Up) 7010 4/96 & UP (All w/Threaded 2 Belt Pulley)	FAPN-8A513AA	7333X
Ford Tractor & Industrial	6700 Thru 7700 w/5/16" & 3/8" Mounting Holes, Same as 7340 Except has Smaller Mounting Holes	FAPN-8A513AD3	7341X
Ford Tractor & Industrial	4310, 4610, 4810, 39 Series (Larger Mounting Holes Than 7331X) (Has Larger Bearing)	N/A	7339X
Ford Truck	6.9L (420) (1) 7.3L (446) (M) E250/350 Diesel	E4T2-8501B	7304X
Ford Truck	7.3L (466) (K) F250/350 Indirect Injection Turbo Diesel	E9TZ-8501B	7304X
Ford Truck	7.3L (466) (F) F250/350 Direct Injection Turbo Diesel	F7TZ-8501CRM	7320X
Ford Truck	7.3L (446) (F) Direct Injection Turbo Diesel	F7TZ-8501CRM	7320X
Ford Truck	7.3L (446) (F) Direct Injection Turbo Diesel	F8IZ-8501ARM	7320X
Ford Truck	7.3L (466) (F) E350 Direct Injection Turbo Diesel	F8IZ-8501ARM	7320X
Ford Truck	7.3L (466) (F) F250/350 Direct Injection Turbo Diesel	F8IZ-8501ARM	7320X
Ford Truck	6.0L Powerstroke, Turbo Diesel	3C3Z-8501ABRM	7323X
Ford Truck	6.0L Diesel, E Series, F Series	4C3Z-8501ABRM	7324X
Ford Truck	6.0L (V8) Diesel, F650, F750	4C4Z-8501AARM	7323X
Ford Truck	370, 429 B, F600/800	D9HZ-8501A	7309X
Ford Truck	370, 429 C, CT600/800	D9HZ-8501A	7309X
Ford Truck	370, 429 L, LN, LNT, LT, LTS800	D9HZ-8501A	7309X
Ford Truck	370, 429 B, F600/800	E2HZ-8501B	7309X
Ford Truck	370, 429 C, CT600/800	E2HZ-8501B	7309X
Ford Truck	370, 429 L, LN, LNT, LT, LTS800	E2HZ-8501B	7309X
Ford Truck	7.3L (446) (M) E250/350, Diesel Non-Turbo	E4T2-8501B	7304X
Ford Truck	7.3L (466) (K) F250/350 Indirect Injection Turbo Diesel	E4TZ-8501C	7304X
Ford Truck	6.9L (420) (1) 7.3L (446) (Diesel) F250/350	E4TZ-8501C	7304X
Ford Truck	7.3L (466) (M) F250/350 Diesel Non-Turbo	E4TZ-8501C	7304X
Ford Truck	7.3L (466) (C) F250/350 Turbo Diesel	E4TZ-8501C	7304X
Ford Truck	7.3L (466) (K) Indirect Injection Turbo Diesel	E4TZ-8501C	7304X
Ford Truck	7.3L (466) (M) Diesel Non Turbo	E4TZ-8501C	7304X
Ford Truck	7.0L 370, 429	E5HZ-8501A	7309X
Ford Truck	7.8L	E7HZ-8501A	7306X
Ford Truck	7.8L (476) CF600/800	E7HZ-8501B	7307X
Ford Truck	6.6L (401) 7.8L (476) Diesel B-F-L600/L900	E8HZ-8501B	7307X
Ford Truck	6.6L (401) 7.8L (476) FNH Diesel	E8HZ-8501B, C	7307X
Ford Truck	7.8L	E8HZ-8501CRM	7306X
Ford Truck	6.6L (401) F600	E8HZ-8501CRM	7307X
Ford Truck	7.3L (466) (M) F250/350 Diesel Non-Turbo	E9TZ-8501B	7304X
Ford Truck	7.3L (466) (C) F250/350 Turbo Diesel	E9TZ-8501B	7304X
Ford Truck	6.9L (420) (1) 7.3L (446) (Diesel) F250/350	E9TZ-8501B	7304X
Ford Truck	7.3L (466) (K) Indirect Injection Turbo Diesel	E9TZ-8501B	7304X
Ford Truck	7.3L (466) (M) Diesel Non Turbo	E9TZ-8501B	7304X
Ford Truck	7.3L (446) (M) E250/350, Diesel Non-Turbo	E9TZ-8501C	7304X
Ford Truck	6.9L (420) (1) 7.3L (446) (M) E250/350 Diesel	E9TZ-8501C	7304X
Ford Truck	6.6L (401) C600/F800 Diesel (w/out Water Pump Mounted Fan, Exc. 210 H.P)	F1HZ-8501C	7311X

Ford Truck	6.6L (401) 7.8L (476) Diesel B-F-FT-L600/L900 (From 10/1/90) (w/out Water Pump Mounted Fan)	F1HZ-8501C	7311X
Ford Truck	6.6L (401) B-C-CF-F800 (w/out Water Pump Mounted Fan)	F1HZ-8501CRM	7311X
Ford Truck	6.6L (401) C600/F800 Diesel (With Water Pump Mounted Fan, Exc. 210 H.P)	F1HZ-8501D	7319X
Ford Truck	6.6L (401) 7.8L (476) Diesel B-F-FT-L600/L900 (From 10/1/90) (With Water Pump Mounted Fan) (Exc. 210 H.P)	F1HZ-8501D	7319X
Ford Truck	6.6L (401) B-C-CF-F800 (With Water Pump Mounted Fan)	F1HZ-8501DRM	7319X
Ford Truck	7.0L 370, 429	F1HZ-8501E	7309X
Ford Truck	7.0L (429) CF800, CFT800 (LPG Gas Only)	F5HZ-8501AA	7309X
Ford Truck	7.3L (466) (F) F250/350 Direct Injection Turbo Diesel	F5TZ-8501A, B, CRM	7314X
Ford Truck	7.3L (466) (F) E250/350 Direct Injection Turbo Diesel	F5TZ-8501BRM	7314X
Ford Truck	7.3L (446) Direct Injection Turbo Diesel	F5TZ-8501BRM	7314X
Ford Truck	7.3L (446) (F) Direct Injection Turbo Diesel	F5TZ-8501BRM	7314X
Ford Truck	7.3L (466) (F) E250/350 Direct Injection Turbo Diesel	F5TZ-8501CRM	7314X
Ford Truck	7.3L (446) Direct Injection Turbo Diesel	F5TZ-8501CRM	7314X
Ford Truck	7.3L (446) (F) Direct Injection Turbo Diesel	F5TZ-8501CRM	7314X
Ford Truck	7.3L (446) (F) Direct Injection Turbo Diesel	F7TZ-8501BRM	7320X
Ford Truck	7.3L (466) (F) E350 Direct Injection Turbo Diesel	F7TZ-8501BRM	7320X
Ford Truck	7.3L (466) (F) E250/350 Direct Injection Turbo Diesel	F7TZ-8501BRM	7320X
Ford Truck	7.3 (446) (F) Diesel	F7TZ-8501BRM	7320X
Ford Truck	7.3L (466) (F) F250/350 Direct Injection Turbo Diesel	F7TZ-8501BRM	7320X
Ford Truck	7.3L (446) (F) Direct Injection Turbo Diesel	F7TZ-8501BRM	7320X
Ford Truck	7.3L (466) (F) E350 Direct Injection Turbo Diesel	F7TZ-8501CRM	7320X
Ford Truck	7.3L (466) (F) E250/350 Direct Injection Turbo Diesel	F7TZ-8501CRM	7320X
Ford Truck	7.3 (446) (F) Diesel	F7TZ-8501CRM,	7320X
Ford Truck	7.3L (446) (F) Direct Injection Turbo Diesel	F7TZ-8501CRM,	7320X
Ford Truck	7.3L (466) (F) E250/350 Direct Injection Turbo Diesel	F8IZ-8501ARM	7320X
Ford Truck	7.3 (446) (F) Diesel	F8IZ-8501ARM	7320X
Ford Truck	7.3L (446) (F) Direct Injection Turbo Diesel	F8IZ-8501ARM	7320X
Ford Truck	F650/750	YC3Z-8501A	7322X
GMC Truck	4.8L (292), Series 50, 60, 2nd Design	357262	7143X
GMC Truck	4.8L (292), Series 50, 60	474056	7143X
GMC Truck	4.8L (292), Series 50, 60, School Bus	474056	7143X
GMC Truck	Series 50, 60, 65 w/6-71 Diesel Eng. Left Hand Mount	5135595	7103X
GMC Truck	Series 50, 60, 65 w/6-71 Diesel Eng. Right Hand Mount	5135596	7104X
GMC Truck	450-900 Series, 3-71, 4-71, 6-71, Diesel Eng. Exc. 6-71T, Right Hand Pump.	5135596	7104X
GMC Truck	5.7L (350), Series 40, 50, 60	6258551	7146X
GMC Truck	6.0L (366), 7.0L (427), 7.4L (454), 60 & 70 Series	10074182	7116X
GMC Truck	4.8L (292), P4 Series	10112691	7143X
GMC Truck	6.0L (366), 7.0L (427) 50, 60, 70 Series, School Bus	10140667	7123X
GMC Truck	6.0L (366) (P) , 7.0L (427) (M) B7& P6 School Bus (50, 60, 70 Series w/Screw on Hub)	10140677	7123X
GMC Truck	7.4L (454) (B&D), B7 School Bus, C6, C7 Topkick	12456231	7145X
GMC Truck	6.0L (366) (P) , 7.0L (427) (M) B7& P6 School Bus (50, 60, 70 Series w/Screw on Hub)	12512740	7123X
GMC Truck	6.2L (379) C, J Diesel,	12514269	7117X
GMC Truck	6.0L (366) (P) , 7.0L (427) (M) B7 School Bus (C5, C6 C7 Series)	12529192	7123X

GMC Truck	6.0L (366) (P) F6, 7 Series	12529192	7123X
GMC Truck	6.0L (366) (P) , 7.0L (427) (M) B7& P6 School Bus (50, 60, 70 Series w/Screw on Hub)	12529192	7123X
GMC Truck	6.5L (395) (F) B7 School Bus, Diesel	12534772	7129X
GMC Truck	6.5L (395) (F) Diesel B7 School Bus, Exc. Hazard Warning Switch (C6, C7 Series)	12534772	7129X
GMC Truck	6.0L (366) (P) , 7.0L (427) (M) B7& P6 School Bus (50, 60, 70 Series w/Screw on Hub)	12551474	7123X
GMC Truck	6.2L (379) C, J Diesel,	15633465	7117X
GMC Truck	8.1L (496) (G) C4500 Thru C8500, B7 School Bus, C6, C7 Topkick	88893907	7144X
Government Postal Vehicles	Model 800, IHC Scout, Mail Truck	2930-073-3473	7312X
Government Postal Vehicles	Model CO/1600, IHC Scout, Mail Truck	2930-073-3473	7312X
Government Postal Vehicles	1 Ton Dodge Mail Truck S6-P200 W170, 225	2930-983-4192	7086X
Hino Truck	Tall Housing	N/A	7901X
International/Harvester	SP-403 w/C263, C282, D282 (To Serial # 2195)	303395R9	7325X
International/Harvester	SP-375 Windrower w/C175	303395R91	7325X
International/Harvester	SP-315 w/D236	303395R91	7325X
International/Harvester	SP-616, 622 Cotton Picker w/C301	303395R91	7325X
International/Harvester	SP-205, 315w/C221	303395R91	7325X
International/Harvester	SP-303 w/C221 (From Serial # 7278)	303395R91	7325X
International/Harvester	SP-503 w/D301	303395R91	7325X
International/Harvester	4 Cyl. Gas 504, 2504 Models	303395R91	7325X
International/Harvester	6 Cyl. Gas 856, 2856 Models & 6 Cyl. Power Units UC221, 263, 291, UD188, 236, 282	303395R91	7325X
International/Harvester	Farmall 460 Diesel	303395R91	7325X
International/Harvester	Farmall 460, 560, 660 Gas Models	303395R91	7325X
International/Harvester	SP-375 Windrower w/C175	601816C91	7325X
International/Harvester	SP-315 w/D236	601816C91	7325X
International/Harvester	SP-616, 622 Cotton Picker w/C301	601816C91	7325X
International/Harvester	SP-205, 315w/C221	601816C91	7325X
International/Harvester	SP-403 w/C263, C282, D282 (To Serial # 2195)	601816C91	7325X
International/Harvester	SP-303 w/C221 (From Serial # 7278)	601816C91	7325X
International/Harvester	SP-503 w/D301	601816C91	7325X
International/Harvester	100C LDR	601816C92	7325X
International/Harvester	3600A w/C263	601816C92	7325X
International/Harvester	D50, w/C301, H-50, A, B, C, w/D188, UD236, UD282, D301	601816C92	7325X
International/Harvester	H-50, A, B, C, w/D188, UD236, UD282, D301	601816C92	7325X
International/Harvester	9000 w/C291, C301	601816C92	7325X
International/Harvester	3800, 3850 w/C263	601816C92	7325X
International/Harvester	H-60B w/C301	601816C92	7325X
International/Harvester	TD9B & 150 LDR	601816C92	7325X
International/Harvester	2500 Consall	601816C92	7325X
International/Harvester	T & TD7	601816C92	7325X
International/Harvester	2656 w/C263 & 3616 w/C221	601816C92	7325X
International/Harvester	2706 w/C263, 291, 2756 w/C291, 2856 w/C301, H-25 PL w/D188, H-30 w/236, 282, H-40 w/V264-6A, TD62 w/263	601816C92	7325X
International/Harvester	Models: H70, H86, 2606, 2706, 2756, 403, 460, 560, 606, 660, 706, 766, 806, 826, 856	601816C92	7325X
International/Harvester	815, 915 w/D414, DT414 Diesel	673162C92	7303X
International/Harvester	All w/D436, DT436 Diesel	673162C92	7303X
International/Harvester	All w/D466, DT466	673162C92	7303X

International/Harvester	966, 1066, 1086, D414, DT414, D436, DT436, D466, DT466 Diesel	673162C92,	7303X
International/Harvester	815, 915 w/D414, DT414 Diesel	673162C94	7303X
International/Harvester	All w/D436, DT436 Diesel	673162C94	7303X
International/Harvester	All w/D466, DT466	673162C94	7303X
International/Harvester	966, 1066, 1086, D414, DT414, D436, DT436, D466, DT466 Diesel	673162C94	7303X
International/Navistar	DI-T444E Bus (7.3L)	182285102	7315X
International/Navistar	9.0L (552) Diesel S Series Medium Duty	1700594C91	7308X
International/Navistar	9.0L (552) Diesel Cargostar	1700594C91	7308X
International/Navistar	9.0L (552) Diesel S Series Medium Duty	1700594C92	7308X
International/Navistar	9.0L (552) Diesel Cargostar	1700594C92	7308X
International/Navistar	7.3L (445) Navistar Diesel 3600, 3700, 3800, 3900FC Bus Chassis Series, 4500, 4600	1800374C91	7305X
International/Navistar	7.3L (445) Navistar Diesel 3600, 3700, 3800, 3900FC Bus Chassis Series, 4500, 4600	1800374C92	7305X
International/Navistar	7.3L (445) Navistar Diesel 1400 Metro, 1452, 1600, 1652 Forward Control Series	1805952C91	7305X
International/Navistar	7.3L (445) Navistar Diesel 3600, 3700, 3800, 3900FC Bus Chassis Series, 4500, 4600	1805952C91	7305X
International/Navistar	6.6L (404), 6.9L (420), 7.3 (446) ,Cargostar, S Medium Series Gas & Diesel	1805952C91	7305X
International/Navistar	6.6L (404), 6.9L (420), 7.3 (446) ,Cargostar, S Medium Series Gas & Diesel	1808374C91	7305X
International/Navistar	7.3L (445) Navistar Diesel 1400 Metro, 1452, 1600, 1652 Forward Control Series	1809374C91	7305X
International/Navistar	7.3L (445) Navistar Diesel 1400 Metro, 1452, 1600, 1652 Forward Control Series	1809374C92	7305X
International/Navistar	6.6L (404), 6.9L (420), 7.3 (446) ,Cargostar, S Medium Series Gas & Diesel	1809374C92	7305X
International/Navistar	7.3L (445) Navistar Diesel 1400 Metro, 1452, 1600, 1652 Forward Control Series	1809374C93	7305X
International/Navistar	7.3L (445) Navistar Diesel 3600, 3700, 3800, 3900FC Bus Chassis Series, 4500, 4600	1809374C93	7305X
International/Navistar	6.6L (404), 6.9L (420), 7.3 (446) ,Cargostar, S Medium Series Gas & Diesel	1809374C93	7305X
International/Navistar	7.3L (445) Navistar Diesel 1400 Metro, 1452, 1600, 1652 Forward Control Series	1809374C94	7305X
International/Navistar	7.3L (445) Navistar Diesel 3600, 3700, 3800, 3900FC Bus Chassis Series, 4500, 4600	1809374C94	7305X
International/Navistar	6.6L (404), 6.9L (420), 7.3 (446) ,Cargostar, S Medium Series Gas & Diesel	1809374C94	7305X
International/Navistar	5.9L (366) DT/DTA Diesel, 7.6L (466) DT/DTA Diesel 1600, 1652, 4500, 4700, 4800, 4900, 7100; Bus Chassis Series 3600, 3700, 3800, 3900CF	1815538C91	7310X
International/Navistar	5.9L (366) DT/DTA Diesel, 7.6L (466) DT/DTA Diesel 1600, 1652, 4500, 4700, 4800, 4900, 7100; Bus Chassis Series 3600, 3700, 3800, 3900CF	1815538C91	7310X
International/Navistar	5.9L (366) DT/DTA Diesel, 7.6L (466) DT/DTA Diesel 1600, 1652, 4500, 4700, 4800, 4900, 7100; Bus Chassis Series 3600, 3700, 3800, 3900CF	1815538C91	7310X
International/Navistar	7.6L (466) Navistar Diesel 2554, 2574, 2654, 2674, 8100, 8200, 8300 Forward Control Series (w/o Electronically Controlled Emissions)	1815538C91	7310X
International/Navistar	7.6L (466) Navistar Diesel (From 10/4/91) 2554, 2574, 2654, 2674, 8100, 8200, 8300	1815538C91	7310X

International/Navistar	7.6L (466) Navistar Diesel 2554, 2574, 2654, 2674, 8100, 8200, 8300 Forward Control Series; 3600, 3700, 3800, 3900FC Bus Chassis Series	1817687C92	7313X
International/Navistar	8.6L (530) Navistar Diesel 1400, 1452, 1600, Metro, 1652, 2554, 2654, 4500, 4600, 8200, 8300, Forward Control Series DT	1817687C94	7313X
International/Navistar	7.6L (466) Navistar Diesel 2554, 2574, 2654, 2674, 8100, 8200, 8300 Forward Control Series; 3600, 3700, 3800, 3900FC Bus Chassis Series	1817687C96	7313X
International/Navistar	7.3, T444E Bus/Truck Diesel	1823669C92	7315X
International/Navistar	DI-T444E Bus (7.3L)	1823669C92	7315X
International/Navistar	DT466 & 530E New Generation (7.6L)	1830607C4	7321X
International/Navistar	DT466 & 530E New Generation (7.6L)	1841764C2	7321X
International/Navistar	DT466 & 530E New Generation (7.6L)	1842664C92	7321X
International/Navistar	DT466 & 530E New Generation (7.6L)	184664C92	7321X
International/Navistar	4.4L (266)	270918C92	7312X
International/Navistar	BC160 To 180 Series, D301 Diesel B	303395R92	<a href="#">7325X</a>
International/Navistar	BC160 To 180 Series, D301 Diesel B	318119R92	<a href="#">7325X</a>
International/Navistar	3.2L (196) (Models w/Fan Clutch)	357621C92	<a href="#">7326X</a>
International/Navistar	5.0L (304), 5.6L (345), 6.4L (392) (Models w/Fan Clutch)	357621C92	7326X
International/Navistar	4.4L (266), 5.0L (304) (Models w/Fan Clutch)	357621C92	<a href="#">7326X</a>
International/Navistar	4.4L (266), 5.0L (304) (Models w/Fan Clutch)	357621C92	<a href="#">7326X</a>
International/Navistar	4.4L (266), 5.0L (304) (Models w/Fan Clutch)	357621C92	<a href="#">7326X</a>
International/Navistar	4.4L (266), 5.0L (304) (Models w/Fan Clutch)	357621C92	<a href="#">7326X</a>
International/Navistar	4.4L (266), 5.0L (304) (Models w/Fan Clutch)	357621C92	<a href="#">7326X</a>
International/Navistar	4.4L (266), 5.0L (304) (Models w/Fan Clutch)	357621C92	<a href="#">7326X</a>
International/Navistar	3.2L (196) (Models w/ Fan Clutch)	357621C92	<a href="#">7326X</a>
International/Navistar	5.0L (304), 5.6L (345) (Models w/Fan Clutch)	357621C92	<a href="#">7326X</a>
International/Navistar	4.4L (266), 5.5L (304), 5.6L (345), 6.4L (392) (Models w/o Fan Clutch)	357621C92	<a href="#">7326X</a>
International/Navistar	3.2L (196) (Models w/o Fan Clutch)	463365C91	7312X
International/Navistar	5.0L (304), 5.6L (345), 6.4L (392) (Models w/o Fan Clutch)	463365C91	7312X
International/Navistar	4.4L (266), 5.0L (304) (Models w/o Fan Clutch)	463365C91	7312X
International/Navistar	4.4L (266), 5.0L (304) (Models w/o Fan Clutch)	463365C91	7312X
International/Navistar	4.4L (266), 5.0L (304) (Models w/o Fan Clutch)	463365C91	7312X
International/Navistar	4.4L (266)	463365C91	7312X
International/Navistar	4.4L (266), 5.0L (304) (Models w/o Fan Clutch)	463365C91	7312X
International/Navistar	4.4L (266), 5.0L (304) (Models w/o Fan Clutch)	463365C91	7312X
International/Navistar	3.2L (196) (Models w/o Fan Clutch)	463365C91	7312X
International/Navistar	3.2L (196) w/Auto Fan	463365C91	7312X
International/Navistar	2.5L (152) w/Auto Fan	463365C91	7312X
International/Navistar	5.0L (304), 5.6L (345) (Models w/o Fan Clutch)	463365C91	7312X
International/Navistar	4.4L (266), 5.5L (304), 5.6L (345), 6.4L (392) (Models w/o Fan Clutch)	463365C91	7312X
International/Navistar	DT466 7.6L (466) Cab over	680899C92	7302X
International/Navistar	7.6L (466) Cab Over Models	680899C93	7312X
International/Navistar	7.6L (466) Conventional Models, DT466 (B)	685155C92	7301X
International/Navistar	7.6L (466) Navistar Diesel To 10/4/91, 2554, 2574, 2654, 8100, 8200, 8300	685155C92	7301X
International/Navistar	5.9L (360) FD1060 Cummins Diesel, 1452, 1624, 1654, 1723, 1724, 1753, 1754, 1824, 1853, 1854, 1924, 1925, 1954, 1955, 2125, 2155	685155C92	7301X

International/Navistar	7.6L (466) Navistar Diesel 1452, 1624, 1654, 1723, 1724, 1753, 1754, 1823, 1824, 1853, 1854, 1924, 1925, 1954, 1955, 2125, 2155 Forward Control Series	685155C92	7301X
International/Navistar	7.6L (466) Conventional Models, DT466 (B)	685155C94	7301X
International/Navistar	7.6L (466) Navistar Diesel To 10/4/91, 2554, 2574, 2654, 8100, 8200, 8300	685155C94	7301X
International/Navistar	5.9L (360) FD1060 Cummins Diesel, 1452, 1624, 1654, 1723, 1724, 1753, 1754, 1824, 1853, 1854, 1924, 1925, 1954, 1955, 2125, 2155	685155C94	7301X
International/Navistar	7.6L (466) Navistar Diesel 1452, 1624, 1654, 1723, 1724, 1753, 1754, 1823, 1824, 1853, 1854, 1924, 1925, 1954, 1955, 2125, 2155 Forward Control Series	685155C94	7301X
International/Navistar	7.6L (466) Conventional Models, DT466 (B)	685155C95	7301X
International/Navistar	7.6L (466) Navistar Diesel To 10/4/91, 2554, 2574, 2654, 8100, 8200, 8300	685155C95	7301X
International/Navistar	5.9L (360) FD1060 Cummins Diesel, 1452, 1624, 1654, 1723, 1724, 1753, 1754, 1824, 1853, 1854, 1924, 1925, 1954, 1955, 2125, 2155	685155C95	7301X
International/Navistar	7.6L (466) Navistar Diesel 1452, 1624, 1654, 1723, 1724, 1753, 1754, 1823, 1824, 1853, 1854, 1924, 1925, 1954, 1955, 2125, 2155 Forward Control Series	685155C95	7301X
International/Navistar	7.6L (466) Navistar Diesel 2554, 2574, 2654, 2674, 8100, 8200, 8300 Forward Control Series (w/o Electronically Controlled Emissions)	735445C91	7310X
International/Navistar	7.6L (466) Navistar Diesel (From 10/4/91) 2554, 2574, 2654, 2674, 8100, 8200, 8300	735445C91	7310X
International/Navistar	4 Cyl. 2.5L (152) (w/Auto Fan)	861236R92	7312X
International/Navistar	2.5L (152) (w/Auto Fan)	861236R92	7312X
International/Navistar	7.3, T444E Bus/Truck Diesel	YC3Z-8501A	7322X
International/Navistar	7.6L (466) Navistar Diesel 2554, 2574, 2654, 2674, 8100, 8200, 8300 Forward Control Series (w/o Electronically Controlled Emissions)	ZGA735327,	7310X
International/Navistar	7.6L (466) Navistar Diesel (From 10/4/91) 2554, 2574, 2654, 2674, 8100, 8200, 8300	ZGA735327,	7310X
International/Navistar	6.6L (404), 6.9L (420), 7.3 (446) ,Cargostar, S Medium Series Gas & Diesel		7305X
International/Navistar	5.6L (V345) Gas 1452, 1624, 1652, 1654, 1723, 1724, 1753, 1754, 1823, 1824, 1853, 1924, 1925, 1954, 1955, 2125 Models		7312X
International	9200 International, Cummins ISX Engine 2013-2007	n/a	7097X
Isuzu Industrial	C201PT (2.2) Diesel, Refrigeration Unit	11 4576	7350X
Isuzu Industrial	5.7L (350)	8-12524-498-0	<a href="#">7354X</a>
Isuzu Industrial		8-94391-670-5	<a href="#">7353X</a>
John Deere	For Models: 5410, 5420, 5510, 5520	N/A	RE500737
Mack	E7, Metric Housing & No Pulley, Long Shaft	31663285A,B,C	7225X
Mack	Maxidyne ESI, ENDT 675, 676, Long Shaft, No Pulley, w/Cast Iron Impeller	316GC1184	7202X
Mack	Thermodyne 673, 675, 711, Short Shaft, No Pulley w/Stamped Steel Impeller	316GC1184	7204X
Mack	Maxidyne ESI, ENDT 675, 676, Long Shaft, w/4 Groove Pulley, w/Stamped Steel Impeller	316GC1184BP2X	7212X
Mack	Maxidyne ENDT 675, 676, Long Shaft, w/Pulley	316GC1184BX	7214X



Mack	Econodyne Charged Air E6, EM6, EMS 6, No Pulley, w/Stamped Steel Impeller	316GC1210A	7208X
Mack	Econodyne Charged Air E6, EM6, EMS 6, w/3 Belt Pulley, w/Stamped Steel Impeller	316GC1210AX	7209X
Mack	Maxidyne ESI, ENDT 675, 676, Long Shaft, No Pulley, w/Cast Iron Impeller	316GC1211A	7202X
Mack	Thermodyne 673, 675, 711, Short Shaft, No Pulley w/Stamped Steel Impeller	316GC1211A	7204X
Mack	675 ESI, ENDT, Long Shaft, w/Notched Pulley for Fan Clutch Applications	316GC1211AX	7215X
Mack	Maxidyne ESI, ENDT 675, 676, Long Shaft, No Pulley, w/Cast Iron Impeller	316GC1211B	7202X
Mack	Maxidyne ESI, ENDT 675, 676, Long Shaft, No Pulley, w/Stamped Steel Impeller	316GC1211B	7205X
Mack	Econodyne, E7, w/Flat Bottom Impeller, No Pulley	316GC1219	7216X
Mack	Econodyne, E7, w/Flat Bottom Impeller, No Pulley	316GC1219A	7216X
Mack	END 673, 675, 676, Short Shaft, No Pulley, w/Cast Iron Impeller	316GC184	7201X
Mack	END 673, 675, 676, w/Hub, Short Shaft w/Stamped Steel Impeller	316GC184N	7206X
Mack	E7 Metric Housing & No Pulley, Short Shaft w/Stamped Impeller	316GC284	7220X
Mack	Granite CV13, eng 460 E Tech. Same as 7230X Except has Larger Pulley O.D.	316GC3196	7230LX
Mack	ACET w/5 1/4" Pulley	316GC3193	7230X
Mack	E7, Long Shaft w/3 Belt Long Pulley & Metric Housing (Long Shaft)	316GC4107MX	7222X
Mack	E7, Long Shaft w/3 Belt Long Pulley & Metric Housing (Long Shaft)	316GC4108MX	7224X
Mack	Maxidyne ESI, ENDT 675, 676, Long Shaft, w/3 Groove Pulley, w/Stamped Steel Impeller	316GC523BX	7211X
Mack	E6 Charged Air, w/3 Groove Pulley & Stamped Steel Impeller	316GC528CX	7210X
Mack	E7 w/3 Belt Pulley, 7 1/4" O.D. & Metric Housing, w/Stamped Impeller (Short Shaft)	316GC548M2X	7217X
Mack	E7, 3 Belt Pulley w/6 5/8" O.D. & Metric Housing (Short Shaft)	316GC548M4X	7223X
Mack	E7 w/3 Belt Pulley, 5 1/2" O.D. & Metric Housing, w/Stamped Impeller (Short Shaft)	316GC548MX	7218X
Mack	E6, 6 5/8" Pulley w/3 Belts and Flat Impeller & B Housing	316GC549M2X	7221X
Mack	E6 w/3 Belt Pulley, 7 1/4" O.D. w/Stamped Impeller & B Housing (Short Shaft)	316GC549MX	7219X
Mack	E7 w/5 1/2" Multi Groove Pulley & 1 V Belt Pulley (Short Shaft)	316GC551M2X	7226X
Mack	E7 w/6 1/4" Multi Groove Pulley & 1 V Belt Pulley (Short Shaft)	316GC551M3X	7228X
Mack	E7 w/6 5/8" Multi Groove Pulley & 1 V Belt Pulley (Short Shaft)	316GC551MX	7227X
Mack	E7 w/Long Multi Groove Pulley (Long Shaft)	316GC552M2X	7229X
Mack	E7 Serial number DM690S28406. Same as 7220X Except has Heavy Duty Bearing	316GC565M8X	7231X
Massey-Ferguson, Massey-Harris		3420050	7086X
Massey-Ferguson, Massey-Harris		3957981	7090X
Massey-Ferguson, Massey-Harris	205, 300 Self-Propelled Gas	1022115M91,	7086X
Massey-Ferguson, Massey-Harris	510 Self-Propelled Gas	1032473M91	7090X
Massey-Ferguson, Massey-Harris		1035836M91,	7090X





<b>OEM Number</b>	<b>Application/ Engine</b>	<b>MAKE</b>	<b>BEPCO PART#</b>
302247	NTC Formula 230 (Short Suitcase w/2 Groove Pulley & 4" Impeller)	Cummins Diesel	7057X
357262	4.8L (292), Series 50, 60, 2nd Design	Chevrolet Truck	7143X
357262	4.8L (292), Series 50, 60, 2nd Design	GMC Truck	7143X
377411	Dina w/Rear engine 155 6cyl & 210 8cyl	Cummins Diesel	7045X
474056	4.8L (292), Series 50, 60	Chevrolet Truck	7143X
474056	4.8L (292), Series 50, 60, School Bus	Chevrolet Truck	7143X
474056	4.8L (292), Series 50, 60	GMC Truck	7143X
474056	4.8L (292), Series 50, 60, School Bus	GMC Truck	7143X
865707	Continental Series Y400 Engine Pump w/Back Plate and 2 Groove Pulley	Clark Truck & Tractor, (4Cyl.)	7036X
865774	Continental Series F162 Engine Pump w/Back Plate and 2 Groove Pulley	Clark Truck & Tractor, (4Cyl.)	7035X
874617	Continental Eng. F163, w/3 Groove Pulley	Allis Chalmers	7033X
874617	Continental Eng. F163, w/3 Groove Pulley	Caterpillar	7033X
11-4576	Isuzu 2.2L C201, C201PT, Refrigeration Unit	Thermo King	7350X
994164	Continental Eng. F162, w/2 Groove Pulley	Allis Chalmers	7032X
994164	Continental Eng. F162, w/2 Groove Pulley	Caterpillar	7032X
994173	Continental Eng. F226, F227, F244, F245, w/2 Groove Pulley	Allis Chalmers	7034X
994173	Continental Eng. F226, F227, F244, F245, w/2 Groove Pulley	Caterpillar	7034X
1006944	3176B, C10, C12, C13 Acert Cast Iron Housing	Caterpillar	7011X
1025844	3176 Aluminum Casting	Caterpillar	7009X
1255863	8.1L, C6, C7, Kodiak, B7 School Bus	Chevrolet Truck	7144X
11-5858	2.2L Direct Injection, w/out Auxiliary Port	Thermo King	7352X
2196910	2.8L (170), 3.7L (225)	Dodge Trucks	7086X
2196910	2.8L (170), 3.2L (198) 3.7L (225)	Dodge Trucks	7086X
2196910	3.7L (225)	Dodge Trucks	7086X
2808679	2.8L (170), 3.2L (198) 3.7L (225)	Dodge Trucks	7086X
2808679	3.2L (198) 3.7L (225)	Dodge Trucks	7086X
2808679	2.8L (170), 3.2L (198) 3.7L (225)	Dodge Trucks	7086X
2808679	3.7L (225)	Dodge Trucks	7086X
2808679	3.7L (225)	Dodge Trucks	7086X
3000886	NTC270-CT, NT855-C280, NTC290, NTC290-R, NTC855-C310, NT310, NTC350, NTA855-C360	Cummins Diesel	7051X
3003731	B Series, 3.9L 4cyl, 5.9L 6cyl. Old Style Pulley w/lip	Cummins Diesel	7063AX
3004923	NTC300, 350, 400: Formula 300, 350, 400, 475 (Suitcase Pump) w/4 11/16" Multi Groove Pulley & 4" Impeller	Cummins Diesel	7061X
3007290	Big Cam	Cummins Diesel	7044X
3007290	Cummins 4000 (14.0)	Cummins Diesel	7044X
3022474	NTC290, NTC350, NTC400, Formula 290, 350 (Suitcase Pump) w/4 11/16" Multi Groove Pulley & 4 1/2" Impeller, Vented	Cummins Diesel	7052X
3022920	KT/KTA 1150	Cummins Diesel	7040X
3024671	Small Cam FFC, w/4 11/16" Multi Groove Pulley & 4" Impeller	Cummins Diesel	7049X
3027174	Ford LTL9000, GMC Brigadier (Suitcase Pump) (5 1/2 Bore) (Not Suitable for Horizontal Eng.) w/4 11/16" Multi Groove Pulley & 4 1/2" Impeller, Vented	Cummins Diesel	7075X
3027882	NTC Formula 230, (Short Suitcase w/4 11/16" Multi Groove Pulley & 4 1/2" Impeller)	Cummins Diesel	7062X
3034969	Multi Groove Idler Pulley	Cummins Diesel	7067X
3045161	Small Cam w/2 Groove Pulley & 4 1/2" Impeller	Cummins Diesel	7050X
3051368	4 11/16" Multi Groove Pulley & 4 1/2" Impeller	Cummins Diesel	7041X
3051378	Big Cam, 4 11/16" Pulley & 4 1/2" Impeller, w/7 Hole Casting, Can use 7052	Cummins Diesel	7042X
3052836	NTC-300, 315, 350, 365, 400, w/Multi Groove Pulley	Cummins Diesel	7060X
3062602	Multi Groove Idler Pulley	Cummins Diesel	7067X

3062930	NTC-300, 315, 350, 365, 400, Idler w/Multi Groove Pulley	Cummins Diesel	7069X
3062930	NTC-300, 315, 350, 365, 400, Idler w/Multi Groove Pulley & Bracket	Cummins Diesel	7074X
3062931	NTC-300, 315, 350, 365, 400, Idler w/Multi Groove Pulley	Cummins Diesel	7069X
3064919	Big Cam, Multi Groove Idler Pulley	Cummins Diesel	7059X
3064920	2 Groove Idler Pulley	Cummins Diesel	7058X
3065000	NTC-300, 315, 350, 365, 400, Idler w/Stamped Pulley	Cummins Diesel	7071X
3066330	N14 Idler Pulley	Cummins Diesel	7073X
3286278	B Series, ISB, 3.9L 4cyl, 5.9L 6cyl. New Style Pulley w/out lip	Cummins Diesel	7063X
3286293	In-Line 6 Cyl.	Cummins Diesel	7076X
3286293	ISC & ISL series, Similar to 7076 except has Larger Casting at Mount w/Larger Impeller.	Cummins Diesel	7082X
3420050		Massey-Ferguson, Massey-Harris	<a href="#">7086X</a>
3420050	2.8L (170), 3.7L (225)	Dodge Trucks	<a href="#">7086X</a>
3420050	2.8L (170), 3.2L (198) 3.7L (225)	Dodge Trucks	<a href="#">7086X</a>
3420050	3.7L (225)	Dodge Trucks	<a href="#">7086X</a>
3420050	3.7L (225)	Dodge Trucks	<a href="#">7086X</a>
3800495	ISX eng. Has 10 Groove Pulley at Top Step	Cummins Diesel	7083X
3800495	ISX eng. Has 12 Groove Pulley at Top Step	Cummins Diesel	7084X
3800745	ISM, M11 w/3 Hole Mount, Short Shaft	Cummins Diesel	7072SSX
3800974	8.3L, Long Noise	Cummins Diesel	7076LX
3800976	8.3L, Long Noise	Cummins Diesel	7076LX
3801234	NTC-300, 315, 350, 365, 400, Idler w/Multi Groove Pulley	Cummins Diesel	7069X
3801708	300, 350, 400, Fleet 300, NTC-Formula 300, 350 400 (w/4 1/2" Multi Groove Pulley & 4 1/2" Impeller) Vented	Cummins Diesel	7064X
3801784	NTC270-CT, NT855-C280, NTC290, NTC290-R, NTC855-C310, NT310, NTC350, NTA855-C360	Cummins Diesel	7051X
3801788	NTC290, NTC350, NTC400, Formula 290, 350 (Suitcase Pump) w/4 11/16" Multi Groove Pulley & 4 1/2" Impeller, Vented	Cummins Diesel	7052X
3801840	LTA10, 240, 270, 300, w/4 hole Mount up to 1991	Cummins Diesel	7066X
3802004	B Series, 3.9L 4cyl, 5.9L 6cyl. Old Style Pulley w/lip	Cummins Diesel	7063AX
3802081	In-Line 6 Cyl.	Cummins Diesel	7076X
3802358	B Series, ISB, 3.9L 4cyl, 5.9L 6cyl. New Style Pulley w/out lip	Cummins Diesel	7063X
3802970	B Series, ISB, 3.9L 4cyl, 5.9L 6cyl. New Style Pulley w/out lip	Cummins Diesel	7063X
3802971	B Series, ISB, 3.9L 4cyl, 5.9L 6cyl. New Style Pulley w/out lip	Cummins Diesel	7063X
3803030	NTC-300, 315, 350, 365, 400, w/Multi Groove Pulley	Cummins Diesel	7060X
3803138	NTC-300, 315, 350, 365, 400, w/Multi Groove Pulley	Cummins Diesel	7060X
3803361	310, 330, 350, 370, 410 w/Multi Groove Pulley	Cummins Diesel	7068X
3803402	LTA10, 240, 270, 300, w/4 hole Mount up to 1991	Cummins Diesel	7066X
3803403	L-10E-MTA 11-330E w/3 Hole Mount, Long Shaft	Cummins Diesel	7072X
3803605	310, 330, 350, 370, 410 w/Multi Groove Pulley	Cummins Diesel	7068X
3804826	N14 - Volvo	Cummins Diesel	7081X
3804927	ISC & ISL series, Similar to 7076 except has Larger Casting at Mount w/Larger Impeller.	Cummins Diesel	7082X
3903749	B Series, ISB, 3.9L 4cyl, 5.9L 6cyl. New Style Pulley w/out lip	Cummins Diesel	7063X
3913432	B Series, ISB, 3.9L 4cyl, 5.9L 6cyl. New Style Pulley w/out lip	Cummins Diesel	7063X
3940052	ISC & ISL series, Similar to 7076 except has Larger Casting at Mount w/Larger Impeller.	Cummins Diesel	7082X

3957981		Massey-Ferguson, Massey-Harris	7090X
	9200 Cummins ISX Engine 2013-2007	International	7097X
3973114	ISC & ISL series, Similar to 7076 except has Larger Casting at Mount w/Larger Impeller.	Cummins Diesel	7082X
4089908	ISX eng. Has 10 Groove Pulley at Top Step	Cummins Diesel	7083X
4106034	3.2L (198) 3.7L (225)	Dodge Trucks	7086X
4106034	2.8L (170), 3.2L (198) 3.7L (225)	Dodge Trucks	7086X
4106034	3.7L (225)	Dodge Trucks	7086X
4131243	3.2L (198) 3.7L (225)	Dodge Trucks	7086X
4131243	2.8L (170), 3.2L (198) 3.7L (225)	Dodge Trucks	7086X
4131243	3.7L (225)	Dodge Trucks	7086X
4429404	5.9L (360) Cummins Turbo Diesel	Dodge Trucks	7063X
4429404	5.9L (360) Cummins Turbo Diesel	Dodge Trucks	7063X
4723690	5.9L (360) Cummins Turbo Diesel	Dodge Trucks	7063X
4723690	5.9L (360) Cummins Turbo Diesel	Dodge Trucks	7063X
5135595	HD-5 Diesel Left Hand	Allis Chalmers	7103X
5135595	HD-7 Diesel Left Hand	Allis Chalmers	7103X
5135595	HD-7 Diesel Left Hand	Allis Chalmers	7103X
5135595	Titan 90 Series w/54 BBC 6V-92T, 6V-92TT, 8V-92T Diesel Eng. Left Hand Mount	Chevrolet Truck	7103X
5135595	Series 50, 60, 65 w/6-71 Diesel Eng. Left Hand Mount	Chevrolet Truck	7103X
5135595	3, 4, 6 Cyl. In Line Engs. (Exc. Turbo) (Left Hand Pump)	Detroit Diesel	7103X
5135595	Series 50, 60, 65 w/6-71 Diesel Eng. Left Hand Mount	GMC Truck	7103X
5135596	HD-5 Diesel Right Hand	Allis Chalmers	7104X
5135596	HD-7 Diesel Right Hand	Allis Chalmers	7104X
5135596	Titan 90 Series w/54 BBC 6-71 Diesel Eng. Right Hand Mount	Chevrolet Truck	7104X
5135596	Series 50, 60, 65 w/6-71 Diesel Eng. Right Hand Mount	Chevrolet Truck	7104X
5135596	Series 90 w/6-71 Diesel Eng.	Chevrolet Truck	7104X
5135596	3, 4, 6 Cyl. In Line Engs. (Exc. Turbo) (Right Hand Pump)	Detroit Diesel	7104X
5135596	Series 50, 60, 65 w/6-71 Diesel Eng. Right Hand Mount	GMC Truck	7104X
5135596	450-900 Series, 3-71, 4-71, 6-71, Diesel Eng. Exc. 6-71T, Right Hand Pump.	GMC Truck	7104X
5144685	Left Hand	Detroit Diesel	7101X
5144687	Right Hand	Detroit Diesel	7102X
5149320	V-6 & V-8 Engines, Walking Pump w/1 Outlet pointing straight down & 1 Outlet at 45 Degree Angle, w/Bolt on Back Cover	Detroit Diesel	7111X
5149321	Standing, w/bolt on Back Cover & w/Heater Provision	Detroit Diesel	7112X
5149326	V-6 & V-8 Engines, Turbo, Standing Pump w/2 Outlets pointing straight Down, High Capacity (w/Bolt on Back Cover)	Detroit Diesel	7107X
5149327	V-8 Engines, Turbo, Running Pump w/2 Outlets at 45 Degree Angles in Opposite Directions, High Capacity (w/Bolt on Back Cover)	Detroit Diesel	7108X
5149328	V-6 & V-8 Engines, Non Turbo, Standing Pump w/2 Outlets pointing straight Down, Standard Capacity (w/Bolt on Back Cover)	Detroit Diesel	7105X
5149329	V-6 & V-8 Engines, Non Turbo, Running Pump w/2 Outlets at 45 Degree Angles in Opposite Directions, Standard Capacity (w/ Bolt on Back Cover)	Detroit Diesel	7106X
5149381	V-8 Engines, Turbo, Running Pump w/2 Outlets at 45 Degree Angles in Opposite Directions, High Capacity (w/Reverse Gear & Bolt on Back Cover)	Detroit Diesel	7115X
5149382	V-8 Engines, Turbo, Standing Pump w/2 Outlets pointing straight Down, High Capacity (w/Reverse	Detroit Diesel	7118X

	Gear & Bolt on Back Cover)		
5149706	3, 4, 6 Cyl. In Line Engs. (Exc. Turbo) (Left Hand Pump)	Detroit Diesel	7103X
5149707	3, 4, 6 Cyl. In Line Engs. (Exc. Turbo) (Right Hand Pump)	Detroit Diesel	7104X
5149708	In-Line A & B Engs. Turbo (Right Hand) High Capacity	Detroit Diesel	7114X
5149710	In-Line A & B Engs. Turbo (Left Hand) High Capacity	Detroit Diesel	7113X
5178318	3, 4, 6 Cyl. In Line Engs. (Exc. Turbo) (Right Hand Pump)	Detroit Diesel	7104X
5178658	Right Hand	Detroit Diesel	7102X
5744662	6.5L (395), B7 School Bus	Chevrolet Truck	<a href="#">7129X</a>
6258551	5.7L (350), Series 40, 50, 60	Chevrolet Truck	<a href="#">7146X</a>
6258551	5.7L (350), Series 40, 50, 60	GMC Truck	<a href="#">7146X</a>
8921104	V-6 & V-8 Engines, Running Pump w/2 Outlets at 45 Degree Angles in Opposite Directions, w/Snap Ring Back Cover	Detroit Diesel	7110X
8921105	V-6 & V-8 Engines, Walking Pump w/1 Outlet pointing straight down & 1 Outlet at 45 Degree Angle, w/Snap Ring Back Cover	Detroit Diesel	7109X
8922302	8 Cyl. Diesel, w/Out Heater Outlet Provision	Detroit Diesel	7119X
8922335	V-6 & V-8 Engines, Running Pump w/2 Outlets at 45 Degree Angles in Opposite Directions, w/Snap Ring Back Cover	Detroit Diesel	7110X
8922336	V-6 & V-8 Engines, Walking Pump w/1 Outlet pointing straight down & 1 Outlet at 45 Degree Angle, w/Snap Ring Back Cover	Detroit Diesel	7109X
8928672	8 Cyl. Diesel, w/Heater Outlet Provision	Detroit Diesel	7120X
10048921	5.7L (350), Series 40, 50, 60	Chevrolet Truck	<a href="#">7146X</a>
10074182	6.0L (366), 7.0L (427) School Bus, 60, 70 Series w/Screw on Hub	Chevrolet Truck	7116X
10074182	7.4L (454), Series 60, 70	Chevrolet Truck	7116X
10074182	6.0L (366), 7.0L (427), 7.4L (454), 60 & 70 Series	GMC Truck	7116X
10112691	4.8L (292), P4 Series	Chevrolet Truck	<a href="#">7143X</a>
10112691	4.8L (292), P4 Series	GMC Truck	<a href="#">7143X</a>
10140667	6.0L (366), 7.0L (427) B7 School Bus, C5, C6, C7 Series w/Screw on Hub	Chevrolet Truck	<a href="#">7123X</a>
10140667	6.0L (366), F6, 7 Series w/Screw on Hub	Chevrolet Truck	<a href="#">7123X</a>
10140667	6.0L (366), 7.0L (427) P6 School Bus, 50, 60, 70 Series w/Screw on Hub	Chevrolet Truck	<a href="#">7123X</a>
10140667	6.0L (366), 7.0L (427) 50, 60, 70 Series, School Bus	GMC Truck	7123X
10140677	6.0L (366) (P) , 7.0L (427) (M) B7& P6 School Bus (50, 60, 70 Series w/Screw on Hub)	GMC Truck	7123X
12456231	7.4L (454) (B&D), B7 School Bus, C6, C7 Topkick	GMC Truck	<a href="#">7145X</a>
12456328	7.4L, B7 School Bus, Kodiak C6, C7, (w/Threaded Hub & Bypass Tube)	Chevrolet Truck	<a href="#">7145X</a>
12512740	6.0L (366) (P) , 7.0L (427) (M) B7& P6 School Bus (50, 60, 70 Series w/Screw on Hub)	GMC Truck	7123X
12514269	6.2L (379) C, J Diesel,	GMC Truck	7117X
12529192	6.0L (366), 7.0L (427) B7 School Bus, C5, C6, C7 Series w/Screw on Hub	Chevrolet Truck	<a href="#">7123X</a>
12529192	6.0L (366) (P) , 7.0L (427) (M) B7 School Bus (C5, C6 C7 Series)	GMC Truck	7123X
12529192	6.0L (366) (P) F6, 7 Series	GMC Truck	7123X
12529192	6.0L (366) (P) , 7.0L (427) (M) B7& P6 School Bus (50, 60, 70 Series w/Screw on Hub)	GMC Truck	7123X
12534772	6.5L (395), B7 School Bus	Chevrolet Truck	<a href="#">7129X</a>
12534772	6.5L (395), B7 School Bus, Exc. Hazard Warning Switch	Chevrolet Truck	<a href="#">7129X</a>
12534772	6.5L (395) (F) B7 School Bus, Diesel	GMC Truck	7129X
12534772	6.5L (395) (F) Diesel B7 School Bus, Exc. Hazard Warning Switch (C6, C7 Series)	GMC Truck	7129X

12551474	6.0L (366) (P) , 7.0L (427) (M) B7& P6 School Bus (50, 60, 70 Series w/Screw on Hub)	GMC Truck	7123X
15633465	6.2L (379) C, J Diesel,	GMC Truck	7117X
23501938	V-6 & V-8 Engines, Non Turbo, Standing Pump w/2 Outlets pointing straight Down, Standard Capacity (w/Bolt on Back Cover)	Detroit Diesel	7105X
23501939	V-6 & V-8 Engines, Non Turbo, Running Pump w/2 Outlets at 45 Degree Angles in Opposite Directions, Standard Capacity (w/ Bolt on Back Cover)	Detroit Diesel	7106X
23501947		Detroit Diesel	7125X
23505019	Front Mount, Before 12/90	Detroit Diesel	7121X
23505895	Rear Mount, After 12/90 (w/ 1/4" Pipe Port)	Detroit Diesel	7122X
23506003	Left Hand	Detroit Diesel	7101X
23506007	Right Hand	Detroit Diesel	7102X
23506204	In-Line A & B Engs. Turbo (Left Hand) High Capacity	Detroit Diesel	7113X
23506602	V-6 & V-8 Engines, Walking Pump w/1 Outlet pointing straight down & 1 Outlet at 45 Degree Angle, w/Snap Ring Back Cover	Detroit Diesel	7109X
23506604	V-6 & V-8 Engines, Walking Pump w/1 Outlet pointing straight down & 1 Outlet at 45 Degree Angle, w/Snap Ring Back Cover & Reverse Gear	Detroit Diesel	7124X
23506623	V-6 & V-8 Engines, Running Pump w/2 Outlets at 45 Degree Angles in Opposite Directions, w/Snap Ring Back Cover	Detroit Diesel	7110X
23506670	V-8 Engines, Turbo, Standing Pump w/2 Outlets pointing straight Down, High Capacity (w/Reverse Gear & Bolt on Back Cover)	Detroit Diesel	7118X
23506698	V-8 Engines, Turbo, Running Pump w/2 Outlets at 45 Degree Angles in Opposite Directions, High Capacity (w/Reverse Gear & Bolt on Back Cover)	Detroit Diesel	7115X
23506711	In-Line A & B Engs. Turbo (Right Hand) High Capacity	Detroit Diesel	7114X
23506723	3, 4, 6 Cyl. In Line Engs. (Exc. Turbo) (Left Hand Pump)	Detroit Diesel	7103X
23506735	3, 4, 6 Cyl. In Line Engs. (Exc. Turbo) (Right Hand Pump)	Detroit Diesel	7104X
23506763	Standing, w/bolt on Back Cover & w/Heater Provision	Detroit Diesel	7112X
23506790	V-6 & V-8 Engines, Turbo, Standing Pump w/2 Outlets pointing straight Down, High Capacity (w/Bolt on Back Cover)	Detroit Diesel	7107X
23506791	V-8 Engines, Turbo, Running Pump w/2 Outlets at 45 Degree Angles in Opposite Directions, High Capacity (w/Bolt on Back Cover)	Detroit Diesel	7108X
23509067	Front Mount, Before 12/90	Detroit Diesel	7121X
23509200	60 Series, Accessory Drive, w/2 Belt Pulley	Detroit Diesel Accessory Drives	9160X
23509200	60 Series, Accessory Drive, w/out Pulley	Detroit Diesel Accessory Drives	9162X
23509201	60 Series, Accessory Drive, w/Multi Groove Pulley	Detroit Diesel Accessory Drives	9161X
23522707	w/6 Vane Impeller, High Capacity (3/8" Pipe Port) w/Steel Back Plate	Detroit Diesel	7126SX
23522707	w/6 Vane Impeller, High Capacity (3/8" Pipe Port)	Detroit Diesel	7126X
23526039	w/6 Vane Impeller, High Capacity, Kangaroo Pouch.	Detroit Diesel	7127X
41312154	Engines 3A-152	Perkins Engine Heavy Duty	<a href="#">7089X</a>
41312159	Engine AD3-153	Perkins Engine Heavy Duty	<a href="#">7088X</a>
41312487			<a href="#">7088X</a>
53020280	3.9L (239)	Dodge Trucks	<a href="#">7087X</a>
53020280	5.2L (318), 5.9L (360)	Dodge Trucks	<a href="#">7087X</a>
53020280	3.9L (239)	Dodge Trucks	<a href="#">7087X</a>
53020280	5.2L (318), 5.9L (360)	Dodge Trucks	<a href="#">7087X</a>
53021018	5.2L (318), 5.9L (360)	Dodge Trucks	<a href="#">7087X</a>
53021018	3.9L (239)	Dodge Trucks	<a href="#">7087X</a>
53021018	5.2L (318), 5.9L (360)	Dodge Trucks	<a href="#">7087X</a>



88893907	8.1L, Kodiak C4500, C5500, C6500, C7500, C8500	Chevrolet Truck	7144X
88893907	8.1L, C6, C7, Kodiak, B7 School Bus	Chevrolet Truck	7144X
88893907	8.1L (496) (G) C4500 Thru C8500, B7 School Bus, C6, C7 Topkick	GMC Truck	7144X
182285102	DI-T444E Bus (7.3L)	International/Navistar	7315X
227-4299	C7, 3126 w/Multi Groove Pulley	Caterpillar	7016MX
3045943RX	300, 350, 400, Fleet 300, NTC-Formula 300, 350 400 (w/4 1/2" Multi Groove Pulley & 4 1/2" Impeller) Vented	Cummins Diesel	7064X
8N-8501	Model 2N, 8N, 9N	Ford Tractor & Industrial	7335X
A906 200 2001	Model U3000, U5000, OM900, OM906	Mercedes-Benz	7401X
AR8855	NTC270-CT, NT855-C280, NTC290, NTC290-R, NTC855-C310, NT310, NTC350, NTA855-C360	Cummins Diesel	7051X
D5NN-8501E	All 2000 thru 7000 Series Gas or Diesel (w/Single Groove Pulley & 4.100" Impeller)	Ford Tractor & Industrial	7330X
DHPN-8A513B	9000, 9200	Ford Tractor & Industrial	7337X
E4T2-8501B	6.9L (420) (1) 7.3L (446) (M) E250/350 Diesel	Ford Truck	7304X
E9TZ-8501B	7.3L (466) (K) F250/350 Indirect Injection Turbo Diesel	Ford Truck	7304X
EAF-8501C	Series 800D, 801D, 900D, 901D, 1800, 4030D, 4031D, 4040D, 4110D, 4120D, 4121D, 4130D, 4131D, 4140D w/D172 Diesel	Ford Tractor & Industrial	7334X
EAF-8501C	Series 800, 801, 900, 901, 1800, 1801, 4030, 4031, 4040, 4110, 4121, 4130, 4131, 4140 w/172 Gas or L.P.G	Ford Tractor & Industrial	7334X
F7TZ-8501CRM	7.3L (466) (F) F250/350 Direct Injection Turbo Diesel	Ford Truck	7320X
F7TZ-8501CRM	7.3L (446) (F) Direct Injection Turbo Diesel	Ford Truck	7320X
F8IZ-8501ARM	7.3L (446) (F) Direct Injection Turbo Diesel	Ford Truck	7320X
F8IZ-8501ARM	7.3L (466) (F) E350 Direct Injection Turbo Diesel	Ford Truck	7320X
F8IZ-8501ARM	7.3L (466) (F) F250/350 Direct Injection Turbo Diesel	Ford Truck	7320X
Y400K-3612	Continental Series Y400 Engine Pump w/Back Plate and 2 Groove Pulley	Clark Truck & Tractor, (4Cyl.)	7036X
0R0781	3208, 636 Cu. Inch Eng. w/pulley	Caterpillar	7002X
0R0781,		Caterpillar	7002X
1022115M91,	205, 300 Self-Propelled Gas	Massey-Ferguson, Massey-Harris	7086X
1032473M91	510 Self-Propelled Gas	Massey-Ferguson, Massey-Harris	7090X
1035836M91,		Massey-Ferguson, Massey-Harris	7090X
1039163M91,		Massey-Ferguson, Massey-Harris	7086X
11 4576	C201PT (2.2) Diesel, Refrigeration Unit	Isuzu Industrial	7350X
11-5858, T-K4576	2.2L Direct Injection, w/Auxiliary Port	Thermo King	7351X
14079-D105	Dina w/Rear engine 155 6cyl & 210 8cyl	Cummins Diesel	7045X
1700594C91	9.0L (552) Diesel S Series Medium Duty	International/Navistar	7308X
1700594C91	9.0L (552) Diesel Cargostar	International/Navistar	7308X
1700594C92	9.0L (552) Diesel S Series Medium Duty	International/Navistar	7308X
1700594C92	9.0L (552) Diesel Cargostar	International/Navistar	7308X
1800374C91	7.3L (445) Navistar Diesel 3600, 3700, 3800, 3900FC Bus Chassis Series, 4500, 4600	International/Navistar	7305X
1800374C92	7.3L (445) Navistar Diesel 3600, 3700, 3800, 3900FC Bus Chassis Series, 4500, 4600	International/Navistar	7305X
1805952C91	7.3L (445) Navistar Diesel 1400 Metro, 1452, 1600, 1652 Forward Control Series	International/Navistar	7305X
1805952C91	7.3L (445) Navistar Diesel 3600, 3700, 3800, 3900FC Bus Chassis Series, 4500, 4600	International/Navistar	7305X
1805952C91	6.6L (404), 6.9L (420), 7.3 (446) ,Cargostar, S Medium Series Gas & Diesel	International/Navistar	7305X
1808374C91	6.6L (404), 6.9L (420), 7.3 (446) ,Cargostar, S Medium Series Gas & Diesel	International/Navistar	7305X

1809374C91	7.3L (445) Navistar Diesel 1400 Metro, 1452, 1600, 1652 Forward Control Series	International/Navistar	7305X
1809374C92	7.3L (445) Navistar Diesel 1400 Metro, 1452, 1600, 1652 Forward Control Series	International/Navistar	7305X
1809374C92	6.6L (404), 6.9L (420), 7.3 (446) ,Cargostar, S Medium Series Gas & Diesel	International/Navistar	7305X
1809374C93	7.3L (445) Navistar Diesel 1400 Metro, 1452, 1600, 1652 Forward Control Series	International/Navistar	7305X
1809374C93	7.3L (445) Navistar Diesel 3600, 3700, 3800, 3900FC Bus Chassis Series, 4500, 4600	International/Navistar	7305X
1809374C93	6.6L (404), 6.9L (420), 7.3 (446) ,Cargostar, S Medium Series Gas & Diesel	International/Navistar	7305X
1809374C94	7.3L (445) Navistar Diesel 1400 Metro, 1452, 1600, 1652 Forward Control Series	International/Navistar	7305X
1809374C94	7.3L (445) Navistar Diesel 3600, 3700, 3800, 3900FC Bus Chassis Series, 4500, 4600	International/Navistar	7305X
1809374C94	6.6L (404), 6.9L (420), 7.3 (446) ,Cargostar, S Medium Series Gas & Diesel	International/Navistar	7305X
1815538C91	5.9L (366) DT/DTA Diesel, 7.6L (466) DT/DTA Diesel 1600, 1652, 4500, 4700, 4800, 4900, 7100; Bus Chassis Series 3600, 3700, 3800, 3900CF	International/Navistar	7310X
1815538C91	5.9L (366) DT/DTA Diesel, 7.6L (466) DT/DTA Diesel 1600, 1652, 4500, 4700, 4800, 4900, 7100; Bus Chassis Series 3600, 3700, 3800, 3900CF	International/Navistar	7310X
1815538C91	5.9L (366) DT/DTA Diesel, 7.6L (466) DT/DTA Diesel 1600, 1652, 4500, 4700, 4800, 4900, 7100; Bus Chassis Series 3600, 3700, 3800, 3900CF	International/Navistar	7310X
1815538C91	7.6L (466) Navistar Diesel 2554, 2574, 2654, 2674, 8100, 8200, 8300 Forward Control Series (w/o Electronically Controlled Emissions)	International/Navistar	7310X
1815538C91	7.6L (466) Navistar Diesel (From 10/4/91) 2554, 2574, 2654, 2674, 8100, 8200, 8300	International/Navistar	7310X
1817687C92	7.6L (466) Navistar Diesel 2554, 2574, 2654, 2674, 8100, 8200, 8300 Forward Control Series; 3600, 3700, 3800, 3900FC Bus Chassis Series	International/Navistar	7313X
1817687C94	8.6L (530) Navistar Diesel 1400, 1452, 1600, Metro, 1652, 2554, 2654, 4500, 4600, 8200, 8300, Forward Control Series DT	International/Navistar	7313X
1817687C96	7.6L (466) Navistar Diesel 2554, 2574, 2654, 2674, 8100, 8200, 8300 Forward Control Series; 3600, 3700, 3800, 3900FC Bus Chassis Series	International/Navistar	7313X
1823669C92	7.3, T444E Bus/Truck Diesel	International/Navistar	7315X
1823669C92	DI-T444E Bus (7.3L)	International/Navistar	7315X
1830607C4	DT466 & 530E New Generation (7.6L)	International/Navistar	7321X
1841764C2	DT466 & 530E New Generation (7.6L)	International/Navistar	7321X
1842664C92	DT466 & 530E New Generation (7.6L)	International/Navistar	7321X
184664C92	DT466 & 530E New Generation (7.6L)	International/Navistar	7321X
1OR0482	3406 B&C, 893 Cu. Inch. Flat Gear w/curved Teeth	Caterpillar	7006X
1OR0483	3406E w/Dome Gear & Curved Teeth	Caterpillar	7006EX
1OR0484	3406E, C15, C16 w/Straight Tooth Dome Gear	Caterpillar	7006EGX
1OR-3326	C17, C18 Acert, C27, Reminds you of 7006EG except Larger Housing, w/Straight Teeth Dome Gear	Caterpillar	7017X
246-3132	C17, C18 Acert, C27, Reminds you of 7006EG except Larger Housing, w/Straight Teeth Dome Gear	Caterpillar	7017X
270918C92	4.4L (266)	International/Navistar	7312X
280-7374	C17, C18 Acert, C27, Reminds you of 7006EG except Larger Housing, w/Straight Teeth Dome Gear	Caterpillar	7017X
2930-073-3473	Model 800, IHC Scout, Mail Truck	Government Postal Vehicles	7312X
2930-073-3473	Model CO/1600, IHC Scout, Mail Truck	Government Postal Vehicles	7312X

2930-983-4192	1 Ton Dodge Mail Truck S6-P200 W170, 225	Government Postal Vehicles	7086X
2N-8501	Model 2N, 8N, 9N	Ford Tractor & Industrial	7335X
2W1225	3208, 636 Cu. Inch Eng. w/pulley	Caterpillar	7002X
2W1227	3208, 636 Cu. Inch Eng. Threaded Pulley for Fan Clutch.	Caterpillar	7004X
303395R9	SP-403 w/C263, C282, D282 (To Serial # 2195)	International/Harvester	7325X
303395R91	SP-375 Windrower w/C175	International/Harvester	7325X
303395R91	SP-315 w/D236	International/Harvester	7325X
303395R91	SP-616, 622 Cotton Picker w/C301	International/Harvester	7325X
303395R91	SP-205, 315w/C221	International/Harvester	7325X
303395R91	SP-303 w/C221 (From Serial # 7278)	International/Harvester	7325X
303395R91	SP-503 w/D301	International/Harvester	7325X
303395R91	4 Cyl. Gas 504, 2504 Models	International/Harvester	7325X
303395R91	6 Cyl. Gas 856, 2856 Models & 6 Cyl. Power Units UC221, 263, 291, UD188, 236, 282	International/Harvester	7325X
303395R91	Farmall 460 Diesel	International/Harvester	7325X
303395R91	Farmall 460, 560, 660 Gas Models	International/Harvester	7325X
303395R92	BC160 To 180 Series, D301 Diesel B	International/Navistar	7325X
3062928,	NTC-300, 315, 350, 365, 400, w/Multi Groove Pulley	Cummins Diesel	7060X
314-5155	C17, C18 Acert, C27, Reminds you of 7006EG except Larger Housing, w/Straight Teeth Dome Gear	Caterpillar	7017X
31663285A,B,C	E7, Metric Housing & No Pulley, Long Shaft	Mack	7225X
316GC1184	Maxidyne ESI, ENDT 675, 676, Long Shaft, No Pulley, w/Cast Iron Impeller	Mack	7202X
316GC1184	Thermodyne 673, 675, 711, Short Shaft, No Pulley w/Stamped Steel Impeller	Mack	7204X
316GC1184BP2X	Maxidyne ESI, ENDT 675, 676, Long Shaft, w/4 Groove Pulley, w/Stamped Steel Impeller	Mack	7212X
316GC1184BX	Maxidyne ENDT 675, 676, Long Shaft, w/Pulley	Mack	7214X
316GC1210A	Econodyne Charged Air E6, EM6, EMS 6, No Pulley, w/Stamped Steel Impeller	Mack	7208X
316GC1210AX	Econodyne Charged Air E6, EM6, EMS 6, w/3 Belt Pulley, w/Stamped Steel Impeller	Mack	7209X
316GC1211A	Maxidyne ESI, ENDT 675, 676, Long Shaft, No Pulley, w/Cast Iron Impeller	Mack	7202X
316GC1211A	Thermodyne 673, 675, 711, Short Shaft, No Pulley w/Stamped Steel Impeller	Mack	7204X
316GC1211AX	675 ESI, ENDT, Long Shaft, w/Notched Pulley for Fan Clutch Applications	Mack	7215X
316GC1211B	Maxidyne ESI, ENDT 675, 676, Long Shaft, No Pulley, w/Cast Iron Impeller	Mack	7202X
316GC1211B	Maxidyne ESI, ENDT 675, 676, Long Shaft, No Pulley, w/Stamped Steel Impeller	Mack	7205X
316GC1219	Econodyne, E7, w/Flat Bottom Impeller, No Pulley	Mack	7216X
316GC1219A	Econodyne, E7, w/Flat Bottom Impeller, No Pulley	Mack	7216X
316GC184	END 673, 675, 676, Short Shaft, No Pulley, w/Cast Iron Impeller	Mack	7201X
316GC184N	END 673, 675, 676, w/Hub, Short Shaft w/Stamped Steel Impeller	Mack	7206X
316GC284	E7 Metric Housing & No Pulley, Short Shaft w/Stamped Impeller	Mack	7220X
316GC3196	Granite CV13, eng 460 E Tech. Same as 7230X Except has Larger Pulley O.D.	Mack	7230LX
316GC3193	ACET w/5 1/4" Pulley	Mack	7230X
316GC4107MX	E7, Long Shaft w/3 Belt Long Pulley & Metric Housing (Long Shaft)	Mack	7222X
316GC4108MX	E7, Long Shaft w/3 Belt Long Pulley & Metric Housing (Long Shaft)	Mack	7224X
316GC523BX	Maxidyne ESI, ENDT 675, 676, Long Shaft, w/3 Groove Pulley, w/Stamped Steel Impeller	Mack	7211X
316GC528CX	E6 Charged Air, w/3 Groove Pulley & Stamped Steel Impeller	Mack	7210X



316GC548M2X	E7 w/3 Belt Pulley, 7 1/4" O.D. & Metric Housing, w/Stamped Impeller (Short Shaft)	Mack	7217X
316GC548M4X	E7, 3 Belt Pulley w/6 5/8" O.D. & Metric Housing (Short Shaft)	Mack	7223X
316GC548MX	E7 w/3 Belt Pulley, 5 1/2" O.D. & Metric Housing, w/Stamped Impeller (Short Shaft)	Mack	7218X
316GC549M2X	E6, 6 5/8" Pulley w/3 Belts and Flat Impeller & B Housing	Mack	7221X
316GC549MX	E6 w/3 Belt Pulley, 7 1/4" O.D. w/Stamped Impeller & B Housing (Short Shaft)	Mack	7219X
316GC551M2X	E7 w/5 1/2" Multi Groove Pulley & 1 V Belt Pulley (Short Shaft)	Mack	7226X
316GC551M3X	E7 w/6 1/4" Multi Groove Pulley & 1 V Belt Pulley (Short Shaft)	Mack	7228X
316GC551MX	E7 w/6 5/8" Multi Groove Pulley & 1 V Belt Pulley (Short Shaft)	Mack	7227X
316GC552M2X	E7 w/Long Multi Groove Pulley (Long Shaft)	Mack	7229X
316GC565M8X	E7 Serial number DM690S28406. Same as 7220X Except has Heavy Duty Bearing	Mack	7231X
318119R92	BC160 To 180 Series, D301 Diesel B	International/Navistar	<a href="#">7325X</a>
3286278RX	5.9L (360) Cummins Turbo Diesel	Dodge Trucks	7063X
34079-B105	Dina w/Rear engine 155 6cyl & 210 8cyl	Cummins Diesel	<a href="#">7045X</a>
3420050,	3.2L (198) 3.7L (225)	Dodge Trucks	<a href="#">7086X</a>
357621C92	3.2L (196) (Models w/Fan Clutch)	International/Navistar	<a href="#">7326X</a>
357621C92	5.0L (304), 5.6L (345), 6.4L (392) (Models w/Fan Clutch)	International/Navistar	7326X
357621C92	4.4L (266), 5.0L (304) (Models w/Fan Clutch)	International/Navistar	<a href="#">7326X</a>
357621C92	4.4L (266), 5.0L (304) (Models w/Fan Clutch)	International/Navistar	<a href="#">7326X</a>
357621C92	4.4L (266), 5.0L (304) (Models w/Fan Clutch)	International/Navistar	<a href="#">7326X</a>
357621C92	4.4L (266), 5.0L (304) (Models w/Fan Clutch)	International/Navistar	<a href="#">7326X</a>
357621C92	4.4L (266), 5.0L (304) (Models w/Fan Clutch)	International/Navistar	<a href="#">7326X</a>
357621C92	3.2L (196) (Models w/ Fan Clutch)	International/Navistar	<a href="#">7326X</a>
357621C92	5.0L (304), 5.6L (345) (Models w/Fan Clutch)	International/Navistar	<a href="#">7326X</a>
357621C92	4.4L (266), 5.5L (304), 5.6L (345), 6.4L (392) (Models w/o Fan Clutch)	International/Navistar	<a href="#">7326X</a>
3800745-RX,	ISM, M11 w/3 Hole Mount, Short Shaft	Cummins Diesel	7072SSX
3804883RX	In-Line 6 Cyl.	Cummins Diesel	7076X
3C3Z-8501ABRM	6.0L Powerstroke, Turbo Diesel	Ford Truck	<a href="#">7323X</a>
4089158RX	ISX eng. Has 10 Groove Pulley at Top Step	Cummins Diesel	7083X
4089647NX	ISC & ISL series, Similar to 7076 except has Larger Casting at Mount w/Larger Impeller.	Cummins Diesel	7082X
463365C91	3.2L (196) (Models w/o Fan Clutch)	International/Navistar	7312X
463365C91	5.0L (304), 5.6L (345), 6.4L (392) (Models w/o Fan Clutch)	International/Navistar	7312X
463365C91	4.4L (266), 5.0L (304) (Models w/o Fan Clutch)	International/Navistar	7312X
463365C91	4.4L (266), 5.0L (304) (Models w/o Fan Clutch)	International/Navistar	7312X
463365C91	4.4L (266), 5.0L (304) (Models w/o Fan Clutch)	International/Navistar	7312X
463365C91	4.4L (266)	International/Navistar	7312X
463365C91	4.4L (266), 5.0L (304) (Models w/o Fan Clutch)	International/Navistar	7312X
463365C91	4.4L (266), 5.0L (304) (Models w/o Fan Clutch)	International/Navistar	7312X
463365C91	3.2L (196) (Models w/o Fan Clutch)	International/Navistar	7312X
463365C91	3.2L (196) w/Auto Fan	International/Navistar	7312X
463365C91	2.5L (152) w/Auto Fan	International/Navistar	7312X
463365C91	5.0L (304), 5.6L (345) (Models w/o Fan Clutch)	International/Navistar	7312X
463365C91	4.4L (266), 5.5L (304), 5.6L (345), 6.4L (392) (Models w/o Fan Clutch)	International/Navistar	7312X
4955708NX	ISM, M11 w/3 Hole Mount, Short Shaft	Cummins Diesel	7072SSX
4C3Z-8501ABRM	6.0L Diesel, E Series, F Series	Ford Truck	<a href="#">7324X</a>
4C4Z-8501AARM	6.0L (V8) Diesel, F650, F750	Ford Truck	<a href="#">7323X</a>
4P3683	3116 w/4 3/8" Pulley	Caterpillar	7012X
4P3683,	3116 w/Fittings	Caterpillar	7012KX
4P9862,	3306 Straight Teeth w/Off Set Holes	Caterpillar	7007GX

4W0253,	3116 w/4 3/8" Pulley	Caterpillar	7012X
4W0253,	3116 w/Fittings	Caterpillar	7012KX
5010964AA	5.9L (360) Cummins Turbo Diesel	Dodge Trucks	7063X
5010964AB	5.9L (360) Cummins Turbo Diesel	Dodge Trucks	7063X
5138057AA	2.7L 2500, 3500	Dodge Trucks	7085X
53021018,	3.9L (239)	Dodge Trucks	7087X
53021018AB	3.9L (239)	Dodge Trucks	7087X
53021018AB	3.9L (239)	Dodge Trucks	7087X
53021018AB	3.9L (239)	Dodge Trucks	7087X
53021018AB,	5.2L (318), 5.9L (360)	Dodge Trucks	7087X
53021018AB,	5.2L (318), 5.9L (360)	Dodge Trucks	7087X
53021018AC	3.9L (239)	Dodge Trucks	7087X
601816C91	SP-375 Windrower w/C175	International/Harvester	7325X
601816C91	SP-315 w/D236	International/Harvester	7325X
601816C91	SP-616, 622 Cotton Picker w/C301	International/Harvester	7325X
601816C91	SP-205, 315w/C221	International/Harvester	7325X
601816C91	SP-403 w/C263, C282, D282 (To Serial # 2195)	International/Harvester	7325X
601816C91	SP-303 w/C221 (From Serial # 7278)	International/Harvester	7325X
601816C91	SP-503 w/D301	International/Harvester	7325X
601816C92	100C LDR	International/Harvester	7325X
601816C92	3600A w/C263	International/Harvester	7325X
601816C92	D50, w/C301, H-50, A, B, C, w/D188, UD236, UD282, D301	International/Harvester	7325X
601816C92	H-50, A, B, C, w/D188, UD236, UD282, D301	International/Harvester	7325X
601816C92	9000 w/C291, C301	International/Harvester	7325X
601816C92	3800, 3850 w/C263	International/Harvester	7325X
601816C92	H-60B w/C301	International/Harvester	7325X
601816C92	TD9B & 150 LDR	International/Harvester	7325X
601816C92	2500 Consall	International/Harvester	7325X
601816C92	T & TD7	International/Harvester	7325X
601816C92	2656 w/C263 & 3616 w/C221	International/Harvester	7325X
601816C92	2706 w/C263, 291, 2756 w/C291, 2856 w/C301, H-25 PL w/D188, H-30 w/236, 282, H-40 w/V264-6A, TD62 w/263	International/Harvester	7325X
601816C92	Models: H70, H86, 2606, 2706, 2756, 403, 460, 560, 606, 660, 706, 766, 806, 826, 856	International/Harvester	7325X
613890-OR4120,	3406E w/Dome Gear & Curved Teeth	Caterpillar	7006EX
613890-OR8218E	3406E w/Dome Gear & Curved Teeth	Caterpillar	7006EX
673162C92	815, 915 w/D414, DT414 Diesel	International/Harvester	7303X
673162C92	All w/D436, DT436 Diesel	International/Harvester	7303X
673162C92	All w/D466, DT466	International/Harvester	7303X
673162C92,	966, 1066, 1086, D414, DT414, D436, DT436, D466, DT466 Diesel	International/Harvester	7303X
673162C94	815, 915 w/D414, DT414 Diesel	International/Harvester	7303X
673162C94	All w/D436, DT436 Diesel	International/Harvester	7303X
673162C94	All w/D466, DT466	International/Harvester	7303X
673162C94	966, 1066, 1086, D414, DT414, D436, DT436, D466, DT466 Diesel	International/Harvester	7303X
680899C92	DT466 7.6L (466) Cab over	International/Navistar	7302X
680899C93	7.6L (466) Cab Over Models	International/Navistar	7312X
685155C92	7.6L (466) Conventional Models, DT466 (B)	International/Navistar	7301X
685155C92	7.6L (466) Navistar Diesel To 10/4/91, 2554, 2574, 2654, 8100, 8200, 8300	International/Navistar	7301X
685155C92	5.9L (360) FD1060 Cummins Diesel, 1452, 1624, 1654, 1723, 1724, 1753, 1754, 1824, 1853, 1854, 1924, 1925, 1954, 1955, 2125, 2155	International/Navistar	7301X
685155C92	7.6L (466) Navistar Diesel 1452, 1624, 1654, 1723, 1724, 1753, 1754, 1823, 1824, 1853, 1854, 1924, 1925, 1954, 1955, 2125, 2155 Forward Control Series	International/Navistar	7301X
685155C94	7.6L (466) Conventional Models, DT466 (B)	International/Navistar	7301X
685155C94	7.6L (466) Navistar Diesel To 10/4/91, 2554, 2574, 2654, 8100, 8200, 8300	International/Navistar	7301X
685155C94	5.9L (360) FD1060 Cummins Diesel, 1452, 1624, 1654, 1723, 1724, 1753, 1754, 1824, 1853, 1854, 1924, 1925, 1954, 1955, 2125, 2155	International/Navistar	7301X

685155C94	7.6L (466) Navistar Diesel 1452, 1624, 1654, 1723, 1724, 1753, 1754, 1823, 1824, 1853, 1854, 1924, 1925, 1954, 1955, 2125, 2155 Forward Control Series	International/Navistar	7301X
685155C95	7.6L (466) Conventional Models, DT466 (B)	International/Navistar	7301X
685155C95	7.6L (466) Navistar Diesel To 10/4/91, 2554, 2574, 2654, 8100, 8200, 8300	International/Navistar	7301X
685155C95	5.9L (360) FD1060 Cummins Diesel, 1452, 1624, 1654, 1723, 1724, 1753, 1754, 1824, 1853, 1854, 1924, 1925, 1954, 1955, 2125, 2155	International/Navistar	7301X
685155C95	7.6L (466) Navistar Diesel 1452, 1624, 1654, 1723, 1724, 1753, 1754, 1823, 1824, 1853, 1854, 1924, 1925, 1954, 1955, 2125, 2155 Forward Control Series	International/Navistar	7301X
6N8413	3306 Angled Teeth w/Off Set Holes & 3 1/8" Bearing	Caterpillar	7007X
734527M91	MF-35, MF-50, MF203, MF-205, Using Perkins Diesel Eng.	Massey-Ferguson, Massey-Harris	7089X
734932M91		Massey-Ferguson, Massey-Harris	7089X
735036M91	MF-135, MF-150, MF-2135, Using Perkins Diesel Eng.	Massey-Ferguson, Massey-Harris	7088X
735445C91	7.6L (466) Navistar Diesel 2554, 2574, 2654, 2674, 8100, 8200, 8300 Forward Control Series (w/o Electronically Controlled Emissions)	International/Navistar	7310X
735445C91	7.6L (466) Navistar Diesel (From 10/4/91) 2554, 2574, 2654, 2674, 8100, 8200, 8300	International/Navistar	7310X
7C4957	3406 B&C, 893 Cu. Inch. Flat Gear w/curved Teeth	Caterpillar	7006X
7C9222	3406 & 3406E Back Plate Kit	Caterpillar	7006BPX
7E8554,	3176 Aluminum Casting	Caterpillar	7009X
7N5909	3304 w/Straight Holes & 2 11/16" Bearing	Caterpillar	7010X
7W7019	3406 B&C, 893 Cu. Inch. Flat Gear w/curved Teeth	Caterpillar	7006X
8-12524-498-0	5.7L (350)	Isuzu Industrial	7354X
830691M91	MF-135, MF-150, MF-2135, Gas Models	Massey-Ferguson, Massey-Harris	7091X
830691M91	TO-35, F-40, H-140, F-35, MF-35, MF50 Gas Models	Massey-Ferguson, Massey-Harris	7091X
835615M91	MF-180, Gas Models	Massey-Ferguson, Massey-Harris	7092X
835615M91	MF-65 Gas Models w/Out Pulley	Massey-Ferguson, Massey-Harris	7092X
8530514M91			7091X
861236R92	4 Cyl. 2.5L (152) (w/Auto Fan)	International/Navistar	7312X
861236R92	2.5L (152) (w/Auto Fan)	International/Navistar	7312X
8-94391-670-5		Isuzu Industrial	7353X
906 200 48 01	Model U3000, U5000, OM900, OM906	Mercedes-Benz	7401X
940 200 04 01	Model ATEGO (OM904)	Mercedes-Benz	7400X
9L7660	1140 & 1160, Models: 1500, 1800 w/3150 eng.	Caterpillar	7005X
9N6147	3208, 636 Cu. Inch Eng. With No Pulley	Caterpillar	7001X
9N6147		Caterpillar	7002X
9N6147	3208, 636 Cu. Inch Eng. w/pulley	Caterpillar	7002X
9N-8501	Model 2N, 8N, 9N	Ford Tractor & Industrial	7335X
9Y4361	3176 Aluminum Casting	Caterpillar	7009X
9Y4879,	3116 w/4 3/8" Pulley	Caterpillar	7012X
9Y4879,	3116 w/Fittings	Caterpillar	7012KX
A146584	Model 600 w/G188D Diesel Eng.	Case	7031X
A146584	430, 470, 480, 530, 570, 580B, 630 Tractors w/G188D Diesel Eng.	Case	7031X
A146584	310E, 310F, 310G, 350, 450 Crawler w/G188D Diesel Eng.	Case	7031X
A146584	480C, 580C, 1845 Tractor Loaders w/G188D Diesel Eng.	Case	7031X
A146584	1150, 1155, 1255 Windrowers w/G188D Diesel Eng.	Case	7031X

A-34079-A05	Dina w/front engine 155 6cyl & 210 8cyl	Cummins Diesel	7043X
A906 200 1301	Model U3000, U5000, OM900, OM906	Mercedes-Benz	7401X
A906 200 1401	Model U3000, U5000, OM900, OM906	Mercedes-Benz	7401X
A906 200 4801	Model U3000, U5000, OM900, OM906	Mercedes-Benz	7401X
AR-04283	Models using Cummins Diesel Straight Eng. NH-250, NHE-225 (High Mounted Fan), NT-280, NT-300, NT-380 (Right Hand Pump)	White Truck and White Autocar	7065X
AR10961	4 11/16" Multi Groove Pulley & 4 1/2" Impeller	Cummins Diesel	7041X
AR-11229RX	V/VT/TA 1710	Cummins Diesel	7078X
AR4283	NH, NT & NTC Non FCC, NH230, NH250, NHC270, NHE225 Diesel, NT280, NT300, NT310, NT335, NT380, NTA380, NTC335, NTC350, NTC380, (Non FCC) w/out Pulley	Cummins Diesel	7065X
AR4284	NH, NT & NTC Non FCC, NH230, NH250, NHC270, NHE225 Diesel, NT280, NT300, NT310, NT335, NT380, NTA380, NTC335, NTC350, NTC380, (Non FCC) w/2 belt Pulley	Cummins Diesel	7053X
AR45073	NTC Formula 230 (Short Suitcase w/2 Groove Pulley & 4" Impeller)	Cummins Diesel	7057X
AR45090	NTC270-CT, NT855-C280, NTC290, NTC290-R, NTC855-C310, NT310, NTC350, NTA855-C360	Cummins Diesel	7051X
AR45184	NTC290, NTC350, NTC400, Formula 290, 350 (Suitcase Pump) w/4 11/16" Multi Groove Pulley & 4 1/2" Impeller, Vented	Cummins Diesel	7052X
AR45189	Big Cam, Multi Groove Idler Pulley	Cummins Diesel	7059X
AR4547	NT & NTC 250 5 1/2" Bore & 9 1/4" Shaft	Cummins Diesel	7054X
AR4548	NT & NTC 250 5 1/2" Bore & 9 7/8" Shaft	Cummins Diesel	7055X
AR51360	NH 250 Military (5 1/2" Bore Shaft) w/pulley	Cummins Diesel	7080X
AR5664	w/3 Belt Pulley	Cummins Diesel	7056X
AR61116	V, VT 555, V8	Cummins Diesel	7070X
AR61788	Dina w/front engine 155 6cyl & 210 8cyl	Cummins Diesel	7043X
AR-61789	Dina w/Rear engine 155 6cyl & 210 8cyl	Cummins Diesel	7045X
AR8851	2 Groove Idler Pulley	Cummins Diesel	7058X
AR9931	w/3 Belt Pulley	Cummins Diesel	7056X
BM50345	220, NHT, NHRS, w/5 1/8" Bore	Cummins Diesel	7047X
BM50356	220, NHT, NHRS, w/5 1/8" Bore	Cummins Diesel	7047X
BM-50446,	Models using Cummins Diesel Straight Eng. NH-180, NH-195, NH-200, NH220 and White Auto Car (Right Hand Pump)	White Truck and White Autocar	7077X
BM50466	H, HF, HR, HRS, NFT, NRT, NRTO, NH220, NHE180, NHE195, NHE220, NHS, NHRS (w/High Mounted Fan) (w/out Pulley) ( Right Hand Mounted Pump)	Cummins Diesel	7077X
BM54327	H, HF, HR, HRS, NFT, NRT, NRTO, NH220, NHE180, NHE195, NHE220, NHS, NHRS (w/Pulley) ( Right Hand Mounted Pump)	Cummins Diesel	7077PX
BM71040	220, NRT, NROT, w/5 1/8" Bore	Cummins Diesel	7048X
BM76506	H, HF, HR, HRS, NFT, NRT, NRTO, NH220, NHE180, NHE195, NHE220, NHS, NHRS (w/High Mounted Fan) (w/out Pulley) ( Right Hand Mounted Pump)	Cummins Diesel	7077X
BM-76506	Models using Cummins Diesel Straight Eng. NH-180, NH-195, NH-200, NH220 and White Auto Car (Right Hand Pump)	White Truck and White Autocar	7077X
C5NN-8501A	2000, 3000, 4000 Series Gas or Diesel (w/Single Groove Pulley & 3.500 Dia. Impeller)	Ford Tractor & Industrial	7331X
C5NN-8501A	5000 Gas or Diesel (w/Single Groove Pulley & 3.500 Dia. Impeller) (Can Use 7330X)	Ford Tractor & Industrial	7331X
C5NN-8501E	All 2000 thru 7000 Series Gas or Diesel (w/Single Groove Pulley & 4.100" Impeller)	Ford Tractor & Industrial	7330X
C9NN-8501B	8000, 8200, 8400	Ford Tractor & Industrial	7337X
C9NN-8501B	9000, 9200	Ford Tractor & Industrial	7337X
CDPN-8501B	NAA, Major	Ford Tractor & Industrial	7338X
CDPN-8501C	134, 172 Tractor & Industrial gas Models 600, 700, 800, 900, 2000, 4000 Series Diesel Models	Ford Tractor & Industrial	7334X



CDPN-8501C	Series 500D, 501D, After Serial #153775; 600D, 601D, 700D, 701D, 2030D, 2031D, 2110D, 2111D, 2120D, 2130D, 2131D w/144 Diesel	Ford Tractor & Industrial	7334X
CDPN-8501C	Series 800D, 801D, 900D, 901D, 1800, 4030D, 4031D, 4040D, 4110D, 4120D, 4121D, 4130D, 4131D, 4140D w/D172 Diesel	Ford Tractor & Industrial	7334X
CDPN-8501C	Series 800, 801, 900, 901, 1800, 1801, 4030, 4031, 4040, 4110, 4121, 4130, 4131, 4140 w/172 Gas or L.P.G	Ford Tractor & Industrial	7334X
CDPN-8501C	Series NAA, 501, 541, 600, 601, 611, 620, 621, 630, 631, 640, 641, 650, 651, 660, 661, 671, 700, 701, 740, 741, 771, 2030, 2031, 2110, 2111, 2120, 2130, 2131 w/134 Gas or L.P.G.	Ford Tractor & Industrial	7334X
CDPN-8501C	Series NAA, 600, 620, 621, 630, 631, 640, 641, 650, 651, 660, 661, 700, 740, 741 w/134 Kerosene Eng.	Ford Tractor & Industrial	7334X
CDPN-8501C	800K, 900K w/172 Kerosene Eng.	Ford Tractor & Industrial	7334X
D1JJ-8501C	134, 172, 192 Gas or Diesel	Ford Tractor & Industrial	7332X
D5NE-8501A	2000, 3000, 4000 Series Gas or Diesel (w/Single Groove Pulley & 3.500 Dia. Impeller)	Ford Tractor & Industrial	7331X
D5NE-8501A	5000 Gas or Diesel (w/Single Groove Pulley & 3.500 Dia. Impeller) (Can Use 7330X)	Ford Tractor & Industrial	7331X
D5NN-8501E	All 2000 thru 7000 Series Gas or Diesel (w/Single Groove Pulley & 4.100" Impeller)	Ford Tractor & Industrial	7330X
D9HZ-8501A	370, 429 B, F600/800	Ford Truck	7309X
D9HZ-8501A	370, 429 C, CT600/800	Ford Truck	7309X
D9HZ-8501A	370, 429 L, LN, LNT, LT, LTS800	Ford Truck	7309X
DHPN-8A513B	8000, 8200, 8400	Ford Tractor & Industrial	7337X
E2HZ-8501B	370, 429 B, F600/800	Ford Truck	7309X
E2HZ-8501B	370, 429 C, CT600/800	Ford Truck	7309X
E2HZ-8501B	370, 429 L, LN, LNT, LT, LTS800	Ford Truck	7309X
E4TZ-8501B	7.3L (446) (M) E250/350, Diesel Non-Turbo	Ford Truck	7304X
E4TZ-8501C	7.3L (466) (K) F250/350 Indirect Injection Turbo Diesel	Ford Truck	7304X
E4TZ-8501C	6.9L (420) (1) 7.3L (446) (Diesel) F250/350	Ford Truck	7304X
E4TZ-8501C	7.3L (466) (M) F250/350 Diesel Non-Turbo	Ford Truck	7304X
E4TZ-8501C	7.3L (466) (C) F250/350 Turbo Diesel	Ford Truck	7304X
E4TZ-8501C	7.3L (466) (K) Indirect Injection Turbo Diesel	Ford Truck	7304X
E4TZ-8501C	7.3L (466) (M) Diesel Non Turbo	Ford Truck	7304X
E5HZ-8501A	7.0L 370, 429	Ford Truck	7309X
E7HZ-8501A	7.8L	Ford Truck	7306X
E7HZ-8501B	7.8L (476) CF600/800	Ford Truck	7307X
E8HZ-8501B	6.6L (401) 7.8L (476) Diesel B-F-L600/L900	Ford Truck	7307X
E8HZ-8501B, C	6.6L (401) 7.8L (476) FNH Diesel	Ford Truck	7307X
E8HZ-8501CRM	7.8L	Ford Truck	7306X
E8HZ-8501CRM	6.6L (401) F600	Ford Truck	7307X
E9TZ-8501B	7.3L (466) (M) F250/350 Diesel Non-Turbo	Ford Truck	7304X
E9TZ-8501B	7.3L (466) (C) F250/350 Turbo Diesel	Ford Truck	7304X
E9TZ-8501B	6.9L (420) (1) 7.3L (446) (Diesel) F250/350	Ford Truck	7304X
E9TZ-8501B	7.3L (466) (K) Indirect Injection Turbo Diesel	Ford Truck	7304X
E9TZ-8501B	7.3L (466) (M) Diesel Non Turbo	Ford Truck	7304X
E9TZ-8501C	7.3L (446) (M) E250/350, Diesel Non-Turbo	Ford Truck	7304X
E9TZ-8501C	6.9L (420) (1) 7.3L (446) (M) E250/350 Diesel	Ford Truck	7304X
EAF-8501C	134, 172 Tractor & Industrial gas Models 600, 700, 800, 900, 2000, 4000 Series Diesel Models	Ford Tractor & Industrial	7334X
EAF-8501C	Series 500D, 501D, After Serial #153775; 600D, 601D, 700D, 701D, 2030D, 2031D, 2110D, 2111D, 2120D, 2130D, 2131D w/144 Diesel	Ford Tractor & Industrial	7334X
EAF-8501C	Series NAA, 501, 541, 600, 601, 611, 620, 621, 630, 631, 640, 641, 650, 651, 660, 661, 671, 700, 701, 740, 741, 771, 2030, 2031, 2110, 2111, 2120, 2130, 2131 w/134 Gas or L.P.G.	Ford Tractor & Industrial	7334X
EAF-8501C	Series NAA, 600, 620, 621, 630, 631, 640, 641, 650, 651, 660, 661, 700, 740, 741 w/134 Kerosene Eng.	Ford Tractor & Industrial	7334X

EAF-8501C	800K, 900K w/172 Kerosene Eng.	Ford Tractor & Industrial	7334X
EAPN-8A513A	2000, 3000, 4000, 5000, 7000 (2600, 3600, 4100, 4600, 5600, 5700, 6600, 6700, 7600, 7700 (2310, 2610, 2810, 2910, 3610, 3910, 4110, 4610 All 2/90) w/5/16" & 7/16" Mounting Holes (2 Groove Pulley) (Large Bearing)	Ford Tractor & Industrial	7340X
EGPN-8A513CA	2000, 3000, 4000, 5000, 7000 (2600, 3600, 4100, 4600, 5600, 5700, 6600, 6700, 7600, 7700 (2310, 2610, 2810, 2910, 3610, 3910, 4110, 4610 All 2/90) w/5/16" & 7/16" Mounting Holes (2 Groove Pulley) (Large Bearing)	Ford Tractor & Industrial	7340X
F162K-3653	Continental Series F162 Engine Pump w/Back Plate and 2 Groove Pulley	Clark Truck & Tractor, (4Cyl.)	7035X
F162K-3653	Series F162 Pump Using F400K-422 Body, w/Back Plate and 2 Groove Pulley HD206K-305	Continental Motors, (4Cyl.)	7035X
F1HZ-8501C	6.6L (401) C600/F800 Diesel (w/out Water Pump Mounted Fan, Exc. 210 H.P)	Ford Truck	7311X
F1HZ-8501C	6.6L (401) 7.8L (476) Diesel B-F-FT-L600/L900 (From 10/1/90) (w/out Water Pump Mounted Fan)	Ford Truck	7311X
F1HZ-8501CRM	6.6L (401) B-C-CF-F800 (w/out Water Pump Mounted Fan)	Ford Truck	7311X
F1HZ-8501D	6.6L (401) C600/F800 Diesel (With Water Pump Mounted Fan, Exc. 210 H.P)	Ford Truck	7319X
F1HZ-8501D	6.6L (401) 7.8L (476) Diesel B-F-FT-L600/L900 (From 10/1/90) (With Water Pump Mounted Fan) (Exc. 210 H.P)	Ford Truck	7319X
F1HZ-8501DRM	6.6L (401) B-C-CF-F800 (With Water Pump Mounted Fan)	Ford Truck	7319X
F1HZ-8501E	7.0L 370, 429	Ford Truck	7309X
F3HZ8501B,	In-Line 6 Cyl.	Cummins Diesel	7076X
F5HZ-8501AA	7.0L (429) CF800, CFT800 (LPG Gas Only)	Ford Truck	7309X
F5TZ-8501A, B, CRM	7.3L (466) (F) F250/350 Direct Injection Turbo Diesel	Ford Truck	7314X
F5TZ-8501BRM	7.3L (466) (F) E250/350 Direct Injection Turbo Diesel	Ford Truck	7314X
F5TZ-8501BRM	7.3L (446) Direct Injection Turbo Diesel	Ford Truck	7314X
F5TZ-8501BRM	7.3L (446) (F) Direct Injection Turbo Diesel	Ford Truck	7314X
F5TZ-8501CRM	7.3L (466) (F) E250/350 Direct Injection Turbo Diesel	Ford Truck	7314X
F5TZ-8501CRM	7.3L (446) Direct Injection Turbo Diesel	Ford Truck	7314X
F5TZ-8501CRM	7.3L (446) (F) Direct Injection Turbo Diesel	Ford Truck	7314X
F6JE-8501BA	4.9L (300) Industrial Eng.	Ford Tractor & Industrial	7336X
F7TZ-8501BRM	7.3L (446) (F) Direct Injection Turbo Diesel	Ford Truck	7320X
F7TZ-8501BRM	7.3L (466) (F) E350 Direct Injection Turbo Diesel	Ford Truck	7320X
F7TZ-8501BRM	7.3L (466) (F) E250/350 Direct Injection Turbo Diesel	Ford Truck	7320X
F7TZ-8501BRM	7.3 (446) (F) Diesel	Ford Truck	7320X
F7TZ-8501BRM	7.3L (466) (F) F250/350 Direct Injection Turbo Diesel	Ford Truck	7320X
F7TZ-8501BRM	7.3L (446) (F) Direct Injection Turbo Diesel	Ford Truck	7320X
F7TZ-8501CRM	7.3L (466) (F) E350 Direct Injection Turbo Diesel	Ford Truck	7320X
F7TZ-8501CRM	7.3L (466) (F) E250/350 Direct Injection Turbo Diesel	Ford Truck	7320X
F7TZ-8501CRM,	7.3 (446) (F) Diesel	Ford Truck	7320X
F7TZ-8501CRM,	7.3L (446) (F) Direct Injection Turbo Diesel	Ford Truck	7320X
F8IZ-8501ARM	7.3L (466) (F) E250/350 Direct Injection Turbo Diesel	Ford Truck	7320X
F8IZ-8501ARM	7.3 (446) (F) Diesel	Ford Truck	7320X
F8IZ-8501ARM	7.3L (446) (F) Direct Injection Turbo Diesel	Ford Truck	7320X
FAPN-8A513AA	Models (5110, 5610, 6610, 6810, 7410, 7610, 7710 All 11/88 & Up) 7010 4/96 & UP (All w/Threaded 2 Belt Pulley)	Ford Tractor & Industrial	7333X
FAPN-8A513AD3	6700 Thru 7700 w/5/16" & 3/8" Mounting Holes, Same as 7340 Except has Smaller Mounting Holes	Ford Tractor & Industrial	7341X
G-11956	Model 150 w/400 Eng.	Case	7030X

G-11956	Model 600 w/G188B Eng.	Case	7030X
G-11956	310D, 310F Utility, 430, 440, 530, 540, 540C, 541, 541C Gas Models	Case	7030X
G-11956	200B, 210B, 300B, 310B, 400B, 500B, 600B, 610B Gas Models	Case	7030X
G-11956	200, 210, 300, 310, 400, 500, 600, 610 Gas Models	Case	7030X
G-11956	300, 320, 350, 351 Gas Models	Case	7030X
G-11956	VA, VAC Series (After No. 72-E07778	Case	7030X
N/A	3116 w/3 3/4" Pulley	Caterpillar	7015X
N/A	Similar to 7016M Except has Hub	Caterpillar	7016X
N/A	220, Smaller top Bearing w/Snap Ring in Second Slot	Cummins Diesel	7047SX
N/A	KT/KTA 1710, 2300	Cummins Diesel	7079X
23531258	EGR, 14L	Detroit Diesel	7142X
N/A	4310, 4610, 4810, 39 Series (Larger Mounting Holes Than 7331X) (Has Larger Bearing)	Ford Tractor & Industrial	7339X
N/A	Tall Housing	Hino Truck	7901X
N/A	For Models: 5410, 5420, 5510, 5520	John Deere	RE500737
OR0644	1140 & 1160, Models: 1500, 1800 w/3150 eng.	Caterpillar	7005X
OR0705,	3176B, C10, C12, C13 Acert Cast Iron Housing	Caterpillar	7011X
OR0781	3208 w/press on pulley	Caterpillar	7008X
OR1002	3306 w/Solid Gear & 2 11/16" Bearing Similar to 7007	Caterpillar	7014X
OR1002	Same as above with Straight Teeth	Caterpillar	7014GX
OR1003	3306 Reminds you of 7007 Except has 2 3/8" Bearing	Caterpillar	7013X
OR1013	3116 w/Fittings	Caterpillar	7012KX
OR1013	3116 w/4 3/8" Pulley	Caterpillar	7012X
OR3007	3116 w/Fittings	Caterpillar	7012KX
OR3007	3116 w/4 3/8" Pulley	Caterpillar	7012X
OR3709	3176B, C10, C12, C13 Acert Cast Iron Housing	Caterpillar	7011X
OR4117	3176 Aluminum Casting	Caterpillar	7009X
OR8217	3406 B&C, 893 Cu. Inch. Flat Gear w/curved Teeth	Caterpillar	7006X
OR8532	3306 Straight Teeth w/Off Set Holes	Caterpillar	7007GX
OR8766,	3176 Aluminum Casting	Caterpillar	7009X
OR8767	3176B, C10, C12, C13 Acert Cast Iron Housing	Caterpillar	7011X
OR9493	3306 Straight Teeth w/Off Set Holes	Caterpillar	7007GX
OR9497	3306 Reminds you of 7007 Except has 2 3/8" Bearing	Caterpillar	7013X
OR9785	3306 w/Solid Gear & 2 11/16" Bearing Similar to 7007	Caterpillar	7014X
OR9869	3406E, C15, C16 w/Straight Tooth Dome Gear	Caterpillar	7006EGX
R23531245	EGR, 14L	Detroit Diesel	7141X
R3505895	Rear Mount, After 12/90 (w/ 1/4" Pipe Port)	Detroit Diesel	7122X
R23514989	Front Mount, Before 12/90	Detroit Diesel	7121X
R3520136	Rear Mount, After 12/90 (w/ 1/4" Pipe Port)	Detroit Diesel	7122X
Y400K-3612	Series Y400 Pump Using Y400K-410 Body, w/Back Plate and 2 Groove Pulley Y91K-336	Continental Motors, (4Cyl.)	7036X
YC3Z-8501A	F650/750	Ford Truck	7322X
YC3Z-8501A	7.3, T444E Bus/Truck Diesel	International/Navistar	7322X
ZGA735327,	7.6L (466) Navistar Diesel 2554, 2574, 2654, 2674, 8100, 8200, 8300 Forward Control Series (w/o Electronically Controlled Emissions)	International/Navistar	7310X
ZGA735327,	7.6L (466) Navistar Diesel (From 10/4/91) 2554, 2574, 2654, 2674, 8100, 8200, 8300	International/Navistar	7310X
	6.6L (404), 6.9L (420), 7.3 (446) ,Cargostar, S Medium Series Gas & Diesel	International/Navistar	7305X
	5.6L (V345) Gas 1452, 1624, 1652, 1654, 1723, 1724, 1753, 1754, 1823, 1824, 1853, 1924, 1925, 1954, 1955, 2125 Models	International/Navistar	7312X



--	--	--	--

<b>BEPKO PART #</b>	<b>Application/ Engine</b>	<b>OEM Number</b>	<b>MAKE</b>
7001X	3208, 636 Cu. Inch Eng. With No Pulley	9N6147	Caterpillar
7002X	3208, 636 Cu. Inch Eng. w/pulley	2W1225	Caterpillar
7002X		0R0781,	Caterpillar
7002X		9N6147	Caterpillar
7002X	3208, 636 Cu. Inch Eng. w/pulley	0R0781	Caterpillar
7002X	3208, 636 Cu. Inch Eng. w/pulley	9N6147	Caterpillar
7004X	3208, 636 Cu. Inch Eng. Threaded Pulley for Fan Clutch.	2W1227	Caterpillar
7005X	1140 & 1160, Models: 1500, 1800 w/3150 eng.	9L7660	Caterpillar
7005X	1140 & 1160, Models: 1500, 1800 w/3150 eng.	OR0644	Caterpillar
7006BPX	3406 & 3406E Back Plate Kit	7C9222	Caterpillar
7006EGX	3406E, C15, C16 w/Straight Tooth Dome Gear	1OR0484	Caterpillar
7006EGX	3406E, C15, C16 w/Straight Tooth Dome Gear	OR9869	Caterpillar
7006EX	3406E w/Dome Gear & Curved Teeth	613890-OR4120,	Caterpillar
7006EX	3406E w/Dome Gear & Curved Teeth	1OR0483	Caterpillar
7006EX	3406E w/Dome Gear & Curved Teeth	613890-OR8218E	Caterpillar
7006X	3406 B&C, 893 Cu. Inch. Flat Gear w/curved Teeth	7W7019	Caterpillar
7006X	3406 B&C, 893 Cu. Inch. Flat Gear w/curved Teeth	1OR0482	Caterpillar
7006X	3406 B&C, 893 Cu. Inch. Flat Gear w/curved Teeth	7C4957	Caterpillar
7006X	3406 B&C, 893 Cu. Inch. Flat Gear w/curved Teeth	OR8217	Caterpillar
7007GX	3306 Straight Teeth w/Off Set Holes	OR8532	Caterpillar
7007GX	3306 Straight Teeth w/Off Set Holes	4P9862,	Caterpillar
7007GX	3306 Straight Teeth w/Off Set Holes	OR9493	Caterpillar
7007X	3306 Angled Teeth w/Off Set Holes & 3 1/8" Bearing	6N8413	Caterpillar
7008X	3208 w/press on pulley	OR0781	Caterpillar
7009X	3176 Aluminum Casting	1025844	Caterpillar
7009X	3176 Aluminum Casting	OR4117	Caterpillar
7009X	3176 Aluminum Casting	OR8766,	Caterpillar
7009X	3176 Aluminum Casting	9Y4361	Caterpillar
7009X	3176 Aluminum Casting	7E8554,	Caterpillar
7010X	3304 w/Straight Holes & 2 11/16" Bearing	7N5909	Caterpillar
7011X	3176B, C10, C12, C13 Acert Cast Iron Housing	1006944	Caterpillar
7011X	3176B, C10, C12, C13 Acert Cast Iron Housing	OR8767	Caterpillar
7011X	3176B, C10, C12, C13 Acert Cast Iron Housing	OR3709	Caterpillar
7011X	3176B, C10, C12, C13 Acert Cast Iron Housing	OR0705,	Caterpillar
7012KX	3116 w/Fittings	OR3007	Caterpillar
7012KX	3116 w/Fittings	OR1013	Caterpillar
7012KX	3116 w/Fittings	9Y4879,	Caterpillar
7012KX	3116 w/Fittings	4P3683,	Caterpillar
7012KX	3116 w/Fittings	4W0253,	Caterpillar
7012X	3116 w/4 3/8" Pulley	OR3007	Caterpillar
7012X	3116 w/4 3/8" Pulley	OR1013	Caterpillar
7012X	3116 w/4 3/8" Pulley	9Y4879,	Caterpillar
7012X	3116 w/4 3/8" Pulley	4P3683	Caterpillar
7012X	3116 w/4 3/8" Pulley	4W0253,	Caterpillar
7013X	3306 Reminds you of 7007 Except has 2 3/8" Bearing	OR9497	Caterpillar
7013X	3306 Reminds you of 7007 Except has 2 3/8" Bearing	OR1003	Caterpillar
7014X	3306 w/Solid Gear & 2 11/16" Bearing Similar to 7007	OR9785	Caterpillar
7014X	3306 w/Solid Gear & 2 11/16" Bearing Similar to 7007	OR1002	Caterpillar
7014GX	Same as above except with Straight Teeth	OR1002	Caterpillar

7015X	3116 w/3 3/4" Pulley	N/A	Caterpillar
7016MX	C7, 3126 w/Multi Groove Pulley	227-4299	Caterpillar
7016X	Similar to 7016M Except has Hub	N/A	Caterpillar
7017X	C17, C18 Acert, C27, Reminds you of 7006EG except Larger Housing, w/Straight Teeth Dome Gear	1OR-3326	Caterpillar
7017X	C17, C18 Acert, C27, Reminds you of 7006EG except Larger Housing, w/Straight Teeth Dome Gear	246-3132	Caterpillar
7017X	C17, C18 Acert, C27, Reminds you of 7006EG except Larger Housing, w/Straight Teeth Dome Gear	280-7374	Caterpillar
7017X	C17, C18 Acert, C27, Reminds you of 7006EG except Larger Housing, w/Straight Teeth Dome Gear	314-5155	Caterpillar
7021X	3306 40LH Tooth Gear	OR2853, 2W8003	Caterpillar
7030X	Model 150 w/400 Eng.	G-11956	Case
7030X	Model 600 w/G188B Eng.	G-11956	Case
7030X	310D, 310F Utility, 430, 440, 530, 540, 540C, 541, 541C Gas Models	G-11956	Case
7030X	200B, 210B, 300B, 310B, 400B, 500B, 600B, 610B Gas Models	G-11956	Case
7030X	200, 210, 300, 310, 400, 500, 600, 610 Gas Models	G-11956	Case
7030X	300, 320, 350, 351 Gas Models	G-11956	Case
7030X	VA, VAC Series (After No. 72-E07778	G-11956	Case
7031X	Model 600 w/G188D Diesel Eng.	A146584	Case
7031X	430, 470, 480, 530, 570, 580B, 630 Tractors w/G188D Diesel Eng.	A146584	Case
7031X	310E, 310F, 310G, 350, 450 Crawler w/G188D Diesel Eng.	A146584	Case
7031X	480C, 580C, 1845 Tractor Loaders w/G188D Diesel Eng.	A146584	Case
7031X	1150, 1155, 1255 Windrowers w/G188D Diesel Eng.	A146584	Case
7032X	Continental Eng. F162, w/2 Groove Pulley	994164	Allis Chalmers
7032X	Continental Eng. F162, w/2 Groove Pulley	994164	Caterpillar
7033X	Continental Eng. F163, w/3 Groove Pulley	874617	Allis Chalmers
7033X	Continental Eng. F163, w/3 Groove Pulley	874617	Caterpillar
7034X	Continental Eng. F226, F227, F244, F245, w/2 Groove Pulley	994173	Allis Chalmers
7034X	Continental Eng. F226, F227, F244, F245, w/2 Groove Pulley	994173	Caterpillar
7035X	Continental Series F162 Engine Pump w/Back Plate and 2 Groove Pulley	865774	Clark Truck & Tractor, (4Cyl.)
7035X	Continental Series F162 Engine Pump w/Back Plate and 2 Groove Pulley	F162K-3653	Clark Truck & Tractor, (4Cyl.)
7035X	Series F162 Pump Using F400K-422 Body, w/Back Plate and 2 Groove Pulley HD206K-305	F162K-3653	Continental Motors, (4Cyl.)
7036X	Continental Series Y400 Engine Pump w/Back Plate and 2 Groove Pulley	865707	Clark Truck & Tractor, (4Cyl.)
7036X	Continental Series Y400 Engine Pump w/Back Plate and 2 Groove Pulley	Y400K-3612	Clark Truck & Tractor, (4Cyl.)
7036X	Series Y400 Pump Using Y400K-410 Body, w/Back Plate and 2 Groove Pulley Y91K-336	Y400K-3612	Continental Motors, (4Cyl.)
7040X	KT/KTA 1150	3022920	Cummins Diesel
7041X	4 11/16" Multi Groove Pulley & 4 1/2" Impeller	3051368	Cummins Diesel
7041X	4 11/16" Multi Groove Pulley & 4 1/2" Impeller	AR10961	Cummins Diesel

7042X	Big Cam, 4 11/16" Pulley & 4 1/2" Impeller, w/7 Hole Casting, Can use 7052	3051378	Cummins Diesel
7043X	Dina w/front engine 155 6cyl & 210 8cyl	A-34079-A05	Cummins Diesel
7043X	Dina w/front engine 155 6cyl & 210 8cyl	AR61788	Cummins Diesel
7044X	Big Cam	3007290	Cummins Diesel
7044X	Cummins 4000 (14.0)	3007290	Cummins Diesel
7045X	Dina w/Rear engine 155 6cyl & 210 8cyl	AR-61789	Cummins Diesel
7045X	Dina w/Rear engine 155 6cyl & 210 8cyl	377411	Cummins Diesel
7045X	Dina w/Rear engine 155 6cyl & 210 8cyl	34079-B105	Cummins Diesel
7045X	Dina w/Rear engine 155 6cyl & 210 8cyl	14079-D105	Cummins Diesel
7047SX	220, Smaller top Bearing w/Snap Ring in Second Slot	N/A	Cummins Diesel
7047X	220, NHT, NHRS, w/5 1/8" Bore	BM50345,BM50356	Cummins Diesel
7048X	220, NRT, NROT, w/5 1/8" Bore	BM71040	Cummins Diesel
7049X	Small Cam FFC, w/4 11/16" Multi Groove Pulley & 4" Impeller	3024671	Cummins Diesel
7050X	Small Cam w/2 Groove Pulley & 4 1/2" Impeller	3045161	Cummins Diesel
7051X	NTC270-CT, NT855-C280, NTC290, NTC290-R, NTC855-C310, NT310, NTC350, NTA855-C360	3000886	Cummins Diesel
7051X	NTC270-CT, NT855-C280, NTC290, NTC290-R, NTC855-C310, NT310, NTC350, NTA855-C360	AR8855	Cummins Diesel
7051X	NTC270-CT, NT855-C280, NTC290, NTC290-R, NTC855-C310, NT310, NTC350, NTA855-C360	AR45090	Cummins Diesel
7051X	NTC270-CT, NT855-C280, NTC290, NTC290-R, NTC855-C310, NT310, NTC350, NTA855-C360	3801784	Cummins Diesel
7052X	NTC290, NTC350, NTC400, Formula 290, 350 (Suitcase Pump) w/4 11/16" Multi Groove Pulley & 4 1/2" Impeller, Vented	3022474	Cummins Diesel
7052X	NTC290, NTC350, NTC400, Formula 290, 350 (Suitcase Pump) w/4 11/16" Multi Groove Pulley & 4 1/2" Impeller, Vented	AR45184	Cummins Diesel
7052X	NTC290, NTC350, NTC400, Formula 290, 350 (Suitcase Pump) w/4 11/16" Multi Groove Pulley & 4 1/2" Impeller, Vented	3801788	Cummins Diesel
7053X	NH, NT & NTC Non FCC, NH230, NH250, NHC270, NHE225 Diesel, NT280, NT300, NT310, NT335, NT380, NTA380, NTC335, NTC350, NTC380, (Non FCC) w/2 belt Pulley	AR4284	Cummins Diesel
7054X	NT & NTC 250 5 1/2" Bore & 9 1/4" Shaft	AR4547	Cummins Diesel
7055X	NT & NTC 250 5 1/2" Bore & 9 7/8" Shaft	AR4548	Cummins Diesel
7056X	w/3 Belt Pulley	AR5664	Cummins Diesel
7056X	w/3 Belt Pulley	AR9931	Cummins Diesel
7057X	NTC Formula 230 (Short Suitcase w/2 Groove Pulley & 4" Impeller)	302247	Cummins Diesel
7057X	NTC Formula 230 (Short Suitcase w/2 Groove Pulley & 4" Impeller)	AR45073	Cummins Diesel
7058X	2 Groove Idler Pulley	AR8851	Cummins Diesel
7058X	2 Groove Idler Pulley	3064920	Cummins Diesel
7059X	Big Cam, Multi Groove Idler Pulley	AR45189	Cummins Diesel
7059X	Big Cam, Multi Groove Idler Pulley	3064919	Cummins Diesel
7060X	NTC-300, 315, 350, 365, 400, w/Multi Groove Pulley	3803138	Cummins Diesel
7060X	NTC-300, 315, 350, 365, 400, w/Multi Groove Pulley	3803030	Cummins Diesel
7060X	NTC-300, 315, 350, 365, 400, w/Multi Groove Pulley	3062928,	Cummins Diesel
7060X	NTC-300, 315, 350, 365, 400, w/Multi Groove Pulley	3052836	Cummins Diesel
7061X	NTC300, 350, 400: Formula 300, 350, 400, 475 (Suitcase Pump) w/4 11/16" Multi Groove Pulley & 4"	3004923	Cummins Diesel

	Impeller		
7062X	NTC Formula 230, (Short Suitcase w/4 11/16" Multi Groove Pulley & 4 1/2" Impeller)	3027882	Cummins Diesel
7063AX	B Series, 3.9L 4cyl, 5.9L 6cyl. Old Style Pulley w/lip	3003731	Cummins Diesel
7063AX	B Series, 3.9L 4cyl, 5.9L 6cyl. Old Style Pulley w/lip	3802004	Cummins Diesel
7063X	B Series, ISB, 3.9L 4cyl, 5.9L 6cyl. New Style Pulley w/out lip	3903749	Cummins Diesel
7063X	B Series, ISB, 3.9L 4cyl, 5.9L 6cyl. New Style Pulley w/out lip	3802971	Cummins Diesel
7063X	B Series, ISB, 3.9L 4cyl, 5.9L 6cyl. New Style Pulley w/out lip	3802970	Cummins Diesel
7063X	B Series, ISB, 3.9L 4cyl, 5.9L 6cyl. New Style Pulley w/out lip	3802358	Cummins Diesel
7063X	B Series, ISB, 3.9L 4cyl, 5.9L 6cyl. New Style Pulley w/out lip	3286278	Cummins Diesel
7063X	B Series, ISB, 3.9L 4cyl, 5.9L 6cyl. New Style Pulley w/out lip	3913432	Cummins Diesel
7063X	5.9L (360) Cummins Turbo Diesel	4429404	Dodge Trucks
7063X	5.9L (360) Cummins Turbo Diesel	4723690	Dodge Trucks
7063X	5.9L (360) Cummins Turbo Diesel	5010964AB	Dodge Trucks
7063X	5.9L (360) Cummins Turbo Diesel	5010964AA	Dodge Trucks
7063X	5.9L (360) Cummins Turbo Diesel	3286278RX	Dodge Trucks
7063X	5.9L (360) Cummins Turbo Diesel	4429404	Dodge Trucks
7063X	5.9L (360) Cummins Turbo Diesel	4723690	Dodge Trucks
7064X	300, 350, 400, Fleet 300, NTC-Formula 300, 350 400 (w/4 1/2" Multi Groove Pulley & 4 1/2" Impeller) Vented	3801708	Cummins Diesel
7064X	300, 350, 400, Fleet 300, NTC-Formula 300, 350 400 (w/4 1/2" Multi Groove Pulley & 4 1/2" Impeller) Vented	3045943RX	Cummins Diesel
7065X	NH, NT & NTC Non FCC, NH230, NH250, NHC270, NHE225 Diesel, NT280, NT300, NT310, NT335, NT380, NTA380, NTC335, NTC350, NTC380, (Non FCC) w/out Pulley	AR4283	Cummins Diesel
7065X	Models using Cummins Diesel Straight Eng. NH-250, NHE-225 (High Mounted Fan), NT-280, NT-300, NT-380 (Right Hand Pump)	AR-04283	White Truck and White Autocar
7066X	LTA10, 240, 270, 300, w/4 hole Mount up to 1991	3801840	Cummins Diesel
7066X	LTA10, 240, 270, 300, w/4 hole Mount up to 1991	3803402	Cummins Diesel
7067X	Multi Groove Idler Pulley	3034969	Cummins Diesel
7067X	Multi Groove Idler Pulley	3062602	Cummins Diesel
7068X	310, 330, 350, 370, 410 w/Multi Groove Pulley	3803605	Cummins Diesel
7068X	310, 330, 350, 370, 410 w/Multi Groove Pulley	3803361	Cummins Diesel
7069X	NTC-300, 315, 350, 365, 400, Idler w/Multi Groove Pulley	3062931	Cummins Diesel
7069X	NTC-300, 315, 350, 365, 400, Idler w/Multi Groove Pulley	3801234	Cummins Diesel
7069X	NTC-300, 315, 350, 365, 400, Idler w/Multi Groove Pulley	3062930	Cummins Diesel
7070X	V, VT 555, V8	AR61116	Cummins Diesel
7071X	NTC-300, 315, 350, 365, 400, Idler w/Stamped Pulley	3065000	Cummins Diesel
7072SSX	ISM, M11 w/3 Hole Mount, Short Shaft	3800745-RX,	Cummins Diesel
7072SSX	ISM, M11 w/3 Hole Mount, Short Shaft	4955708NX	Cummins Diesel
7072SSX	ISM, M11 w/3 Hole Mount, Short Shaft	3800745	Cummins Diesel

7072X	L-10E-MTA 11-330E w/3 Hole Mount, Long Shaft	3803403	Cummins Diesel
7072SLX	ISM, M11 w/3 Hole Mount, Short Shaft	4089389, 4955708	Cummins Diesel
7073X	N14 Idler Pulley	3066330	Cummins Diesel
7074X	NTC-300, 315, 350, 365, 400, Idler w/Multi Groove Pulley & Bracket	3062930	Cummins Diesel
7075X	Ford LTL9000, GMC Brigadier (Suitcase Pump) (5 1/2 Bore) (Not Suitable for Horizontal Eng.s.) w/4 11/16" Multi Groove Pulley & 4 1/2" Impeller, Vented	3027174	Cummins Diesel
7076LX	8.3L, Long Noise	3800976	Cummins Diesel
7076LX	8.3L, Long Noise	3800974	Cummins Diesel
7076X	In-Line 6 Cyl.	3802081	Cummins Diesel
7076X	In-Line 6 Cyl.	3804883RX	Cummins Diesel
7076X	In-Line 6 Cyl.	F3HZ8501B,	Cummins Diesel
7076X	In-Line 6 Cyl.	3286293	Cummins Diesel
7077PX	H, HF, HR, HRS, NFT, NRT, NRTO, NH220, NHE180, NHE195, NHE220, NHS, NHRS (w/Pulley) ( Right Hand Mounted Pump)	BM54327	Cummins Diesel
7077X	H, HF, HR, HRS, NFT, NRT, NRTO, NH220, NHE180, NHE195, NHE220, NHS, NHRS (w/High Mounted Fan) (w/out Pulley) ( Right Hand Mounted Pump)	BM50466	Cummins Diesel
7077X	H, HF, HR, HRS, NFT, NRT, NRTO, NH220, NHE180, NHE195, NHE220, NHS, NHRS (w/High Mounted Fan) (w/out Pulley) ( Right Hand Mounted Pump)	BM76506	Cummins Diesel
7077X	Models using Cummins Diesel Straight Eng.s. NH-180, NH-195, NH-200, NH220 and White Auto Car (Right Hand Pump)	BM-50446,	White Truck and White Autocar
7077X	Models using Cummins Diesel Straight Eng.s. NH-180, NH-195, NH-200, NH220 and White Auto Car (Right Hand Pump)	BM-76506	White Truck and White Autocar
7078X	V/VT/TA 1710	AR-11229RX	Cummins Diesel
7079X	KT/KTA 1710, 2300	N/A	Cummins Diesel
7080X	NH 250 Military (5 1/2" Bore Shaft) w/pulley	AR51360	Cummins Diesel
7081X	N14 - Volvo	3804826	Cummins Diesel
7082X	ISC & ISL series, Similar to 7076 except has Larger Casting at Mount w/Larger Impeller.	3286293	Cummins Diesel
7082X	ISC & ISL series, Similar to 7076 except has Larger Casting at Mount w/Larger Impeller.	3973114	Cummins Diesel
7082X	ISC & ISL series, Similar to 7076 except has Larger Casting at Mount w/Larger Impeller.	3804927	Cummins Diesel
7082X	ISC & ISL series, Similar to 7076 except has Larger Casting at Mount w/Larger Impeller.	3940052	Cummins Diesel
7082X	ISC & ISL series, Similar to 7076 except has Larger Casting at Mount w/Larger Impeller.	4089647NX	Cummins Diesel
7083X	ISX eng. Has 10 Groove Pulley at Top Step	3800495	Cummins Diesel
7083X	ISX eng. Has 10 Groove Pulley at Top Step	4089908	Cummins Diesel
7083X	ISX eng. Has 10 Groove Pulley at Top Step	4089158RX	Cummins Diesel
7084X	ISX eng. Has 12 Groove Pulley at Top Step	3800495	Cummins Diesel
7085X	2.7L 2500, 3500	5138057AA	Dodge Trucks
7086X	205, 300 Self-Propelled Gas	1022115M91,	Massey-Ferguson, Massey-Harris
7086X		1039163M91,	Massey-Ferguson, Massey-Harris
7086X		3420050	Massey-Ferguson, Massey-Harris
7086X	2.8L (170), 3.2L (198) 3.7L (225)	2808679	Dodge Trucks

7086X	2.8L (170), 3.7L (225)	2196910	Dodge Trucks
7086X	2.8L (170), 3.7L (225)	3420050	Dodge Trucks
7086X	3.2L (198) 3.7L (225)	4131243	Dodge Trucks
7086X	3.2L (198) 3.7L (225)	2808679	Dodge Trucks
7086X	3.2L (198) 3.7L (225)	3420050,	Dodge Trucks
7086X	3.2L (198) 3.7L (225)	4106034	Dodge Trucks
7086X	2.8L (170), 3.2L (198) 3.7L (225)	4131243	Dodge Trucks
7086X	2.8L (170), 3.2L (198) 3.7L (225)	4106034	Dodge Trucks
7086X	2.8L (170), 3.2L (198) 3.7L (225)	3420050	Dodge Trucks
7086X	2.8L (170), 3.2L (198) 3.7L (225)	2808679	Dodge Trucks
7086X	2.8L (170), 3.2L (198) 3.7L (225)	2196910	Dodge Trucks
7086X	3.7L (225)	3420050	Dodge Trucks
7086X	3.7L (225)	2808679	Dodge Trucks
7086X	3.7L (225)	2196910	Dodge Trucks
7086X	3.7L (225)	4131243	Dodge Trucks
7086X	3.7L (225)	2808679	Dodge Trucks
7086X	3.7L (225)	4106034	Dodge Trucks
7086X	3.7L (225)	3420050	Dodge Trucks
7086X	1 Ton Dodge Mail Truck S6-P200 W170, 225	2930-983-4192	Government Postal Vehicles
7087X	3.9L (239)	53021018AB	Dodge Trucks
7087X	3.9L (239)	53020280	Dodge Trucks
7087X	3.9L (239)	53021018,	Dodge Trucks
7087X	5.2L (318), 5.9L (360)	53021018AB,	Dodge Trucks
7087X	5.2L (318), 5.9L (360)	53020280	Dodge Trucks
7087X	5.2L (318), 5.9L (360)	53021018	Dodge Trucks
7087X	3.9L (239)	53021018AB	Dodge Trucks
7087X	3.9L (239)	53020280	Dodge Trucks
7087X	3.9L (239)	53021018	Dodge Trucks
7087X	3.9L (239)	53021018AC	Dodge Trucks
7087X	5.2L (318), 5.9L (360)	53021018AB,	Dodge Trucks
7087X	5.2L (318), 5.9L (360)	53020280	Dodge Trucks
7087X	5.2L (318), 5.9L (360)	53021018	Dodge Trucks
7087X	3.9L (239)	53021018AB	Dodge Trucks
7088X	MF-135, MF-150, MF-2135, Using Perkins Diesel Eng.	735036M91	Massey-Ferguson, Massey-Harris
7088X	Engine AD3-153	41312159	Perkins Engine Heavy Duty
7088X		41312487	
7089X	MF-35, MF-50, MF203, MF-205, Using Perkins Diesel Eng.	734527M91	Massey-Ferguson, Massey-Harris
7089X		734932M91	Massey-Ferguson, Massey-Harris
7089X	Engines 3A-152	41312154	Perkins Engine Heavy Duty
7090X	510 Self-Propelled Gas	1032473M91	Massey-Ferguson, Massey-Harris
7090X		3957981	Massey-Ferguson, Massey-Harris
7090X		1035836M91,	Massey-Ferguson, Massey-Harris
7091X	MF-135, MF-150, MF-2135, Gas Models	830691M91	Massey-Ferguson, Massey-Harris
7091X	TO-35, F-40, H-140, F-35, MF-35, MF50 Gas Models	830691M91	Massey-Ferguson, Massey-Harris
7091X		8530514M91	
7092X	MF-180, Gas Models	835615M91	Massey-Ferguson, Massey-Harris
7092X	MF-65 Gas Models w/Out Pulley	835615M91	Massey-Ferguson, Massey-Harris



7097X	9200 International Cummins ISX Engine 2013-2007	3683652	International
7101X	Left Hand	5144685	Detroit Diesel
7101X	Left Hand	23506003	Detroit Diesel
7102X	Right Hand	5144687	Detroit Diesel
7102X	Right Hand	5178658	Detroit Diesel
7102X	Right Hand	23506007	Detroit Diesel
7103X	HD-5 Diesel Left Hand	5135595	Allis Chalmers
7103X	HD-7 Diesel Left Hand	5135595	Allis Chalmers
7103X	HD-7 Diesel Left Hand	5135595	Allis Chalmers
7103X	Titan 90 Series w/54 BBC 6V-92T, 6V-92TT, 8V-92T Diesel Eng. Left Hand Mount	5135595	Chevrolet Truck
7103X	Series 50, 60, 65 w/6-71 Diesel Eng. Left Hand Mount	5135595	Chevrolet Truck
7103X	3, 4, 6 Cyl. In Line Engs. (Exc. Turbo) (Left Hand Pump)	5135595	Detroit Diesel
7103X	3, 4, 6 Cyl. In Line Engs. (Exc. Turbo) (Left Hand Pump)	5149706	Detroit Diesel
7103X	3, 4, 6 Cyl. In Line Engs. (Exc. Turbo) (Left Hand Pump)	23506723	Detroit Diesel
7103X	Series 50, 60, 65 w/6-71 Diesel Eng. Left Hand Mount	5135595	GMC Truck
7104X	HD-5 Diesel Right Hand	5135596	Allis Chalmers
7104X	HD-7 Diesel Right Hand	5135596	Allis Chalmers
7104X	Titan 90 Series w/54 BBC 6-71 Diesel Eng. Right Hand Mount	5135596	Chevrolet Truck
7104X	Series 50, 60, 65 w/6-71 Diesel Eng. Right Hand Mount	5135596	Chevrolet Truck
7104X	Series 90 w/6-71 Diesel Eng.	5135596	Chevrolet Truck
7104X	3, 4, 6 Cyl. In Line Engs. (Exc. Turbo) (Right Hand Pump)	5135596	Detroit Diesel
7104X	3, 4, 6 Cyl. In Line Engs. (Exc. Turbo) (Right Hand Pump)	5149707	Detroit Diesel
7104X	3, 4, 6 Cyl. In Line Engs. (Exc. Turbo) (Right Hand Pump)	5178318	Detroit Diesel
7104X	3, 4, 6 Cyl. In Line Engs. (Exc. Turbo) (Right Hand Pump)	23506735	Detroit Diesel
7104X	Series 50, 60, 65 w/6-71 Diesel Eng. Right Hand Mount	5135596	GMC Truck
7104X	450-900 Series, 3-71, 4-71, 6-71, Diesel Eng. Exc. 6-71T, Right Hand Pump.	5135596	GMC Truck
7105X	V-6 & V-8 Engines, Non Turbo, Standing Pump w/2 Outlets pointing straight Down, Standard Capacity (w/Bolt on Back Cover)	5149328	Detroit Diesel
7105X	V-6 & V-8 Engines, Non Turbo, Standing Pump w/2 Outlets pointing straight Down, Standard Capacity (w/Bolt on Back Cover)	23501938	Detroit Diesel
7106X	V-6 & V-8 Engines, Non Turbo, Running Pump w/2 Outlets at 45 Degree Angles in Opposite Directions, Standard Capacity (w/ Bolt on Back Cover)	5149329	Detroit Diesel
7106X	V-6 & V-8 Engines, Non Turbo, Running Pump w/2 Outlets at 45 Degree Angles in Opposite Directions, Standard Capacity (w/ Bolt on Back Cover)	23501939	Detroit Diesel
7107X	V-6 & V-8 Engines, Turbo, Standing Pump w/2 Outlets pointing straight Down, High Capacity (w/Bolt on Back Cover)	5149326	Detroit Diesel

7107X	V-6 & V-8 Engines, Turbo, Standing Pump w/2 Outlets pointing straight Down, High Capacity (w/Bolt on Back Cover)	23506790	Detroit Diesel
7108X	V-8 Engines, Turbo, Running Pump w/2 Outlets at 45 Degree Angles in Opposite Directions, High Capacity (w/Bolt on Back Cover)	5149327	Detroit Diesel
7108X	V-8 Engines, Turbo, Running Pump w/2 Outlets at 45 Degree Angles in Opposite Directions, High Capacity (w/Bolt on Back Cover)	23506791	Detroit Diesel
7109X	V-6 & V-8 Engines, Walking Pump w/1 Outlet pointing straight down & 1 Outlet at 45 Degree Angle, w/Snap Ring Back Cover	8922336	Detroit Diesel
7109X	V-6 & V-8 Engines, Walking Pump w/1 Outlet pointing straight down & 1 Outlet at 45 Degree Angle, w/Snap Ring Back Cover	8921105	Detroit Diesel
7109X	V-6 & V-8 Engines, Walking Pump w/1 Outlet pointing straight down & 1 Outlet at 45 Degree Angle, w/Snap Ring Back Cover	23506602	Detroit Diesel
7110X	V-6 & V-8 Engines, Running Pump w/2 Outlets at 45 Degree Angles in Opposite Directions, w/Snap Ring Back Cover	8922335	Detroit Diesel
7110X	V-6 & V-8 Engines, Running Pump w/2 Outlets at 45 Degree Angles in Opposite Directions, w/Snap Ring Back Cover	8921104	Detroit Diesel
7110X	V-6 & V-8 Engines, Running Pump w/2 Outlets at 45 Degree Angles in Opposite Directions, w/Snap Ring Back Cover	23506623	Detroit Diesel
7111X	V-6 & V-8 Engines, Walking Pump w/1 Outlet pointing straight down & 1 Outlet at 45 Degree Angle, w/Bolt on Back Cover	5149320	Detroit Diesel
7112X	Standing, w/bolt on Back Cover & w/Heater Provision	5149321	Detroit Diesel
7112X	Standing, w/bolt on Back Cover & w/Heater Provision	23506763	Detroit Diesel
7113X	In-Line A & B Engs. Turbo (Left Hand) High Capacity	5149710	Detroit Diesel
7113X	In-Line A & B Engs. Turbo (Left Hand) High Capacity	23506204	Detroit Diesel
7114X	In-Line A & B Engs. Turbo (Right Hand) High Capacity	5149708	Detroit Diesel
7114X	In-Line A & B Engs. Turbo (Right Hand) High Capacity	23506711	Detroit Diesel
7115X	V-8 Engines, Turbo, Running Pump w/2 Outlets at 45 Degree Angles in Opposite Directions, High Capacity (w/Reverse Gear & Bolt on Back Cover)	5149381	Detroit Diesel
7115X	V-8 Engines, Turbo, Running Pump w/2 Outlets at 45 Degree Angles in Opposite Directions, High Capacity (w/Reverse Gear & Bolt on Back Cover)	23506698	Detroit Diesel
7116X	6.0L (366), 7.0L (427) School Bus, 60, 70 Series w/Screw on Hub	10074182	Chevrolet Truck
7116X	7.4L (454), Series 60, 70	10074182	Chevrolet Truck
7116X	6.0L (366), 7.0L (427), 7.4L (454), 60 & 70 Series	10074182	GMC Truck
7117X	6.2L (379) C, J Diesel,	12514269	GMC Truck
7117X	6.2L (379) C, J Diesel,	15633465	GMC Truck
7118X	V-8 Engines, Turbo, Standing Pump w/2 Outlets pointing straight Down, High Capacity (w/Reverse Gear & Bolt on Back Cover)	5149382	Detroit Diesel

7118X	V-8 Engines, Turbo, Standing Pump w/2 Outlets pointing straight Down, High Capacity (w/Reverse Gear & Bolt on Back Cover)	23506670	Detroit Diesel
7119X	8 Cyl. Diesel, w/Out Heater Outlet Provision	8922302	Detroit Diesel
7120X	8 Cyl. Diesel, w/Heater Outlet Provision	8928672	Detroit Diesel
7121X	Front Mount, Before 12/90	23509067	Detroit Diesel
7121X	Front Mount, Before 12/90	23505019	Detroit Diesel
7121X	Front Mount, Before 12/90	R23514989	Detroit Diesel
7122X	Rear Mount, After 12/90 (w/ 1/4" Pipe Port)	23505895	Detroit Diesel
7122X	Rear Mount, After 12/90 (w/ 1/4" Pipe Port)	R3520136	Detroit Diesel
7122X	Rear Mount, After 12/90 (w/ 1/4" Pipe Port)	R3505895	Detroit Diesel
7123X	6.0L (366), 7.0L (427) B7 School Bus, C5, C6, C7 Series w/Screw on Hub	10140667	Chevrolet Truck
7123X	6.0L (366), 7.0L (427) B7 School Bus, C5, C6, C7 Series w/Screw on Hub	12529192	Chevrolet Truck
7123X	6.0L (366), F6, 7 Series w/Screw on Hub	10140667	Chevrolet Truck
7123X	6.0L (366), 7.0L (427) P6 School Bus, 50, 60, 70 Series w/Screw on Hub	10140667	Chevrolet Truck
7123X	6.0L (366) (P) , 7.0L (427) (M) B7 School Bus (C5, C6 C7 Series)	12529192	GMC Truck
7123X	6.0L (366) (P) F6, 7 Series	12529192	GMC Truck
7123X	6.0L (366) (P) , 7.0L (427) (M) B7& P6 School Bus (50, 60, 70 Series w/Screw on Hub)	12529192	GMC Truck
7123X	6.0L (366) (P) , 7.0L (427) (M) B7& P6 School Bus (50, 60, 70 Series w/Screw on Hub)	12551474	GMC Truck
7123X	6.0L (366) (P) , 7.0L (427) (M) B7& P6 School Bus (50, 60, 70 Series w/Screw on Hub)	12512740	GMC Truck
7123X	6.0L (366) (P) , 7.0L (427) (M) B7& P6 School Bus (50, 60, 70 Series w/Screw on Hub)	10140677	GMC Truck
7123X	6.0L (366), 7.0L (427) 50, 60, 70 Series, School Bus	10140667	GMC Truck
7124X	V-6 & V-8 Engines, Walking Pump w/1 Outlet pointing straight down & 1 Outlet at 45 Degree Angle, w/Snap Ring Back Cover & Reverse Gear	23506604	Detroit Diesel
7125X		23501947	Detroit Diesel
7126SX	w/6 Vane Impeller, High Capacity (3/8" Pipe Port) w/Steel Back Plate	23522707	Detroit Diesel
7126X	w/6 Vane Impeller, High Capacity (3/8" Pipe Port)	23522707	Detroit Diesel
7127X	w/6 Vane Impeller, High Capacity, Kangaroo Pouch.	23526039	Detroit Diesel
7129X	6.5L (395), B7 School Bus	12534772	Chevrolet Truck
7129X	6.5L (395), B7 School Bus	5744662	Chevrolet Truck
7129X	6.5L (395), B7 School Bus, Exc. Hazard Warning Switch	12534772	Chevrolet Truck
7129X	6.5L (395) (F) B7 School Bus, Diesel	12534772	GMC Truck
7129X	6.5L (395) (F) Diesel B7 School Bus, Exc. Hazard Warning Switch (C6, C7 Series)	12534772	GMC Truck
7141X	EGR, 14L	R23531245	Detroit Diesel
7142X	EGR, 14L	23531258	Detroit Diesel
7143X	4.8L (292), P4 Series	10112691	Chevrolet Truck
7143X	4.8L (292), Series 50, 60	474056	Chevrolet Truck
7143X	4.8L (292), Series 50, 60, School Bus	474056	Chevrolet Truck
7143X	4.8L (292), Series 50, 60, 2nd Design	357262	Chevrolet Truck
7143X	4.8L (292), P4 Series	10112691	GMC Truck
7143X	4.8L (292), Series 50, 60	474056	GMC Truck

7143X	4.8L (292), Series 50, 60, School Bus	474056	GMC Truck
7143X	4.8L (292), Series 50, 60, 2nd Design	357262	GMC Truck
7144X	8.1L, Kodiak C4500, C5500, C6500, C7500, C8500	88893907	Chevrolet Truck
7144X	8.1L, C6, C7, Kodiak, B7 School Bus	1255863	Chevrolet Truck
7144X	8.1L, C6, C7, Kodiak, B7 School Bus	88893907	Chevrolet Truck
7144X	8.1L (496) (G) C4500 Thru C8500, B7 School Bus, C6, C7 Topkick	88893907	GMC Truck
7145X	7.4L, B7 School Bus, Kodiak C6, C7, (w/Threaded Hub & Bypass Tube)	12456328	Chevrolet Truck
7145X	7.4L (454) (B&D), B7 School Bus, C6, C7 Topkick	12456231	GMC Truck
7146X	5.7L (350), Series 40, 50, 60	10048921	Chevrolet Truck
7146X	5.7L (350), Series 40, 50, 60	6258551	Chevrolet Truck
7146X	5.7L (350), Series 40, 50, 60	6258551	GMC Truck
7201X	END 673, 675, 676, Short Shaft, No Pulley, w/Cast Iron Impeller	316GC184	Mack
7202X	Maxidyne ESI, ENDT 675, 676, Long Shaft, No Pulley, w/Cast Iron Impeller	316GC1184	Mack
7202X	Maxidyne ESI, ENDT 675, 676, Long Shaft, No Pulley, w/Cast Iron Impeller	316GC1211A	Mack
7202X	Maxidyne ESI, ENDT 675, 676, Long Shaft, No Pulley, w/Cast Iron Impeller	316GC1211B	Mack
7204X	Thermodyne 673, 675, 711, Short Shaft, No Pulley w/Stamped Steel Impeller	316GC1184	Mack
7204X	Thermodyne 673, 675, 711, Short Shaft, No Pulley w/Stamped Steel Impeller	316GC1211A	Mack
7205X	Maxidyne ESI, ENDT 675, 676, Long Shaft, No Pulley, w/Stamped Steel Impeller	316GC1211B	Mack
7206X	END 673, 675, 676, w/Hub, Short Shaft w/Stamped Steel Impeller	316GC184N	Mack
7208X	Econodyne Charged Air E6, EM6, EMS 6, No Pulley, w/Stamped Steel Impeller	316GC1210A	Mack
7209X	Econodyne Charged Air E6, EM6, EMS 6, w/3 Belt Pulley, w/Stamped Steel Impeller	316GC1210AX	Mack
7210X	E6 Charged Air, w/3 Groove Pulley & Stamped Steel Impeller	316GC528CX	Mack
7211X	Maxidyne ESI, ENDT 675, 676, Long Shaft, w/3 Groove Pulley, w/Stamped Steel Impeller	316GC523BX	Mack
7212X	Maxidyne ESI, ENDT 675, 676, Long Shaft, w/4 Groove Pulley, w/Stamped Steel Impeller	316GC1184BP2X	Mack
7214X	Maxidyne ENDT 675, 676, Long Shaft, w/Pulley	316GC1184BX	Mack
7215X	675 ESI, ENDT, Long Shaft, w/Notched Pulley for Fan Clutch Applications	316GC1211AX	Mack
7216X	Econodyne, E7, w/Flat Bottom Impeller, No Pulley	316GC1219	Mack
7216X	Econodyne, E7, w/Flat Bottom Impeller, No Pulley	316GC1219A	Mack
7217X	E7 w/3 Belt Pulley, 7 1/4" O.D. & Metric Housing, w/Stamped Impeller (Short Shaft)	316GC548M2X	Mack
7218X	E7 w/3 Belt Pulley, 5 1/2" O.D. & Metric Housing, w/Stamped Impeller (Short Shaft)	316GC548MX	Mack
7219X	E6 w/3 Belt Pulley, 7 1/4" O.D. w/Stamped Impeller & B Housing (Short Shaft)	316GC549MX	Mack
7220X	E7 Metric Housing & No Pulley, Short Shaft w/Stamped Impeller	316GC284	Mack
7221X	E6, 6 5/8" Pulley w/3 Belts and Flat Impeller & B Housing	316GC549M2X	Mack
7222X	E7, Long Shaft w/3 Belt Long Pulley & Metric Housing (Long Shaft)	316GC4107MX	Mack

7223X	E7, 3 Belt Pulley w/6 5/8" O.D. & Metric Housing (Short Shaft)	316GC548M4X	Mack
7224X	E7, Long Shaft w/3 Belt Long Pulley & Metric Housing (Long Shaft)	316GC4108MX	Mack
7225X	E7, Metric Housing & No Pulley, Long Shaft	31663285A,B,C	Mack
7226X	E7 w/5 1/2" Multi Groove Pulley & 1 V Belt Pulley (Short Shaft)	316GC551M2X	Mack
7227X	E7 w/6 5/8" Multi Groove Pulley & 1 V Belt Pulley (Short Shaft)	316GC551MX	Mack
7228X	E7 w/6 1/4" Multi Groove Pulley & 1 V Belt Pulley (Short Shaft)	316GC551M3X	Mack
7229X	E7 w/Long Multi Groove Pulley (Long Shaft)	316GC552M2X	Mack
7230LX	Granite CV13, eng 460 E Tech. Same as 7230X Except has Larger Pulley O.D.	316GC3196	Mack
7230X	ACET w/5 1/4" Pulley	316GC3193	Mack
7231X	E7 Serial number DM690S28406. Same as 7220X Except has Heavy Duty Bearing	316GC565M8X	Mack
7301X	7.6L (466) Conventional Models, DT466 (B)	685155C92	International/Navistar
7301X	7.6L (466) Conventional Models, DT466 (B)	685155C94	International/Navistar
7301X	7.6L (466) Conventional Models, DT466 (B)	685155C95	International/Navistar
7301X	7.6L (466) Navistar Diesel To 10/4/91, 2554, 2574, 2654, 8100, 8200, 8300	685155C92	International/Navistar
7301X	7.6L (466) Navistar Diesel To 10/4/91, 2554, 2574, 2654, 8100, 8200, 8300	685155C94	International/Navistar
7301X	7.6L (466) Navistar Diesel To 10/4/91, 2554, 2574, 2654, 8100, 8200, 8300	685155C95	International/Navistar
7301X	5.9L (360) FD1060 Cummins Diesel, 1452, 1624, 1654, 1723, 1724, 1753, 1754, 1824, 1853, 1854, 1924, 1925, 1954, 1955, 2125, 2155	685155C92	International/Navistar
7301X	5.9L (360) FD1060 Cummins Diesel, 1452, 1624, 1654, 1723, 1724, 1753, 1754, 1824, 1853, 1854, 1924, 1925, 1954, 1955, 2125, 2155	685155C94	International/Navistar
7301X	5.9L (360) FD1060 Cummins Diesel, 1452, 1624, 1654, 1723, 1724, 1753, 1754, 1824, 1853, 1854, 1924, 1925, 1954, 1955, 2125, 2155	685155C95	International/Navistar
7301X	7.6L (466) Navistar Diesel 1452, 1624, 1654, 1723, 1724, 1753, 1754, 1823, 1824, 1853, 1854, 1924, 1925, 1954, 1955, 2125, 2155 Forward Control Series	685155C92	International/Navistar
7301X	7.6L (466) Navistar Diesel 1452, 1624, 1654, 1723, 1724, 1753, 1754, 1823, 1824, 1853, 1854, 1924, 1925, 1954, 1955, 2125, 2155 Forward Control Series	685155C94	International/Navistar
7301X	7.6L (466) Navistar Diesel 1452, 1624, 1654, 1723, 1724, 1753, 1754, 1823, 1824, 1853, 1854, 1924, 1925, 1954, 1955, 2125, 2155 Forward Control Series	685155C95	International/Navistar
7302X	DT466 7.6L (466) Cab over	680899C92	International/Navistar
7303X	815, 915 w/D414, DT414 Diesel	673162C92	International/Harvester
7303X	815, 915 w/D414, DT414 Diesel	673162C94	International/Harvester
7303X	All w/D436, DT436 Diesel	673162C92	International/Harvester
7303X	All w/D436, DT436 Diesel	673162C94	International/Harvester
7303X	All w/D466, DT466	673162C92	International/Harvester
7303X	All w/D466, DT466	673162C94	International/Harvester

7303X	966, 1066, 1086, D414, DT414, D436, DT436, D466, DT466 Diesel	673162C92,	International/Harvester
7303X	966, 1066, 1086, D414, DT414, D436, DT436, D466, DT466 Diesel	673162C94	International/Harvester
7304X	7.3L (446) (M) E250/350, Diesel Non-Turbo	E9TZ-8501C	Ford Truck
7304X	7.3L (446) (M) E250/350, Diesel Non-Turbo	E4TZ-8501B	Ford Truck
7304X	6.9L (420) (1) 7.3L (446) (M) E250/350 Diesel	E9TZ-8501C	Ford Truck
7304X	6.9L (420) (1) 7.3L (446) (M) E250/350 Diesel	E4TZ-8501B	Ford Truck
7304X	7.3L (466) (K) F250/350 Indirect Injection Turbo Diesel	E4TZ-8501C	Ford Truck
7304X	7.3L (466) (K) F250/350 Indirect Injection Turbo Diesel	E9TZ-8501B	Ford Truck
7304X	7.3L (466) (M) F250/350 Diesel Non-Turbo	E4TZ-8501C	Ford Truck
7304X	7.3L (466) (M) F250/350 Diesel Non-Turbo	E9TZ-8501B	Ford Truck
7304X	7.3L (466) (C) F250/350 Turbo Diesel	E4TZ-8501C	Ford Truck
7304X	7.3L (466) (C) F250/350 Turbo Diesel	E9TZ-8501B	Ford Truck
7304X	6.9L (420) (1) 7.3L (446) (Diesel) F250/350	E4TZ-8501C	Ford Truck
7304X	6.9L (420) (1) 7.3L (446) (Diesel) F250/350	E9TZ-8501B	Ford Truck
7304X	7.3L (466) (K) Indirect Injection Turbo Diesel	E4TZ-8501C	Ford Truck
7304X	7.3L (466) (K) Indirect Injection Turbo Diesel	E9TZ-8501B	Ford Truck
7304X	7.3L (466) (M) Diesel Non Turbo	E4TZ-8501C	Ford Truck
7304X	7.3L (466) (M) Diesel Non Turbo	E9TZ-8501B	Ford Truck
7305X	7.3L (445) Navistar Diesel 1400 Metro, 1452, 1600, 1652 Forward Control Series	1805952C91	International/Navistar
7305X	7.3L (445) Navistar Diesel 1400 Metro, 1452, 1600, 1652 Forward Control Series	1809374C91	International/Navistar
7305X	7.3L (445) Navistar Diesel 1400 Metro, 1452, 1600, 1652 Forward Control Series	1809374C92	International/Navistar
7305X	7.3L (445) Navistar Diesel 1400 Metro, 1452, 1600, 1652 Forward Control Series	1809374C93	International/Navistar
7305X	7.3L (445) Navistar Diesel 1400 Metro, 1452, 1600, 1652 Forward Control Series	1809374C94	International/Navistar
7305X	7.3L (445) Navistar Diesel 3600, 3700, 3800, 3900FC Bus Chassis Series, 4500, 4600	1805952C91	International/Navistar
7305X	7.3L (445) Navistar Diesel 3600, 3700, 3800, 3900FC Bus Chassis Series, 4500, 4600	1800374C91	International/Navistar
7305X	7.3L (445) Navistar Diesel 3600, 3700, 3800, 3900FC Bus Chassis Series, 4500, 4600	1800374C92	International/Navistar
7305X	7.3L (445) Navistar Diesel 3600, 3700, 3800, 3900FC Bus Chassis Series, 4500, 4600	1809374C93	International/Navistar
7305X	7.3L (445) Navistar Diesel 3600, 3700, 3800, 3900FC Bus Chassis Series, 4500, 4600	1809374C94	International/Navistar
7305X	6.6L (404), 6.9L (420), 7.3 (446) ,Cargostar, S Medium Series Gas & Diesel	1809374C94	International/Navistar
7305X	6.6L (404), 6.9L (420), 7.3 (446) ,Cargostar, S Medium Series Gas & Diesel	1805952C91	International/Navistar
7305X	6.6L (404), 6.9L (420), 7.3 (446) ,Cargostar, S Medium Series Gas & Diesel	1808374C91	International/Navistar
7305X	6.6L (404), 6.9L (420), 7.3 (446) ,Cargostar, S Medium Series Gas & Diesel	1809374C92	International/Navistar
7305X	6.6L (404), 6.9L (420), 7.3 (446) ,Cargostar, S Medium Series Gas & Diesel	1809374C93	International/Navistar
7305X	6.6L (404), 6.9L (420), 7.3 (446) ,Cargostar, S Medium Series Gas & Diesel		International/Navistar
7306X	7.8L	E7HZ-8501A	Ford Truck
7306X	7.8L	E8HZ-8501CRM	Ford Truck
7307X	6.6L (401) 7.8L (476) Diesel B-F-L600/L900	E8HZ-8501B	Ford Truck

7307X	6.6L (401) 7.8L (476) FNH Diesel	E8HZ-8501B, C	Ford Truck
7307X	6.6L (401) F600	E8HZ-8501CRM	Ford Truck
7307X	7.8L (476) CF600/800	E7HZ-8501B	Ford Truck
7308X	9.0L (552) Diesel S Series Medium Duty	1700594C91	International/Navistar
7308X	9.0L (552) Diesel S Series Medium Duty	1700594C92	International/Navistar
7308X	9.0L (552) Diesel Cargostar	1700594C91	International/Navistar
7308X	9.0L (552) Diesel Cargostar	1700594C92	International/Navistar
7309X	7.0L 370, 429	F1HZ-8501E	Ford Truck
7309X	7.0L (429) CF800, CFT800 (LPG Gas Only)	F5HZ-8501AA	Ford Truck
7309X	7.0L 370, 429	E5HZ-8501A	Ford Truck
7309X	370, 429 B, F600/800	D9HZ-8501A	Ford Truck
7309X	370, 429 B, F600/800	E2HZ-8501B	Ford Truck
7309X	370, 429 C, CT600/800	D9HZ-8501A	Ford Truck
7309X	370, 429 C, CT600/800	E2HZ-8501B	Ford Truck
7309X	370, 429 L, LN, LNT, LT, LTS800	D9HZ-8501A	Ford Truck
7309X	370, 429 L, LN, LNT, LT, LTS800	E2HZ-8501B	Ford Truck
7310X	5.9L (366) DT/DTA Diesel, 7.6L (466) DT/DTA Diesel 1600, 1652, 4500, 4700, 4800, 4900, 7100; Bus Chassis Series 3600, 3700, 3800, 3900CF	1815538C91	International/Navistar
7310X	5.9L (366) DT/DTA Diesel, 7.6L (466) DT/DTA Diesel 1600, 1652, 4500, 4700, 4800, 4900, 7100; Bus Chassis Series 3600, 3700, 3800, 3900CF	1815538C91	International/Navistar
7310X	5.9L (366) DT/DTA Diesel, 7.6L (466) DT/DTA Diesel 1600, 1652, 4500, 4700, 4800, 4900, 7100; Bus Chassis Series 3600, 3700, 3800, 3900CF	1815538C91	International/Navistar
7310X	7.6L (466) Navistar Diesel 2554, 2574, 2654, 2674, 8100, 8200, 8300 Forward Control Series (w/o Electronically Controlled Emissions)	1815538C91	International/Navistar
7310X	7.6L (466) Navistar Diesel 2554, 2574, 2654, 2674, 8100, 8200, 8300 Forward Control Series (w/o Electronically Controlled Emissions)	735445C91	International/Navistar
7310X	7.6L (466) Navistar Diesel 2554, 2574, 2654, 2674, 8100, 8200, 8300 Forward Control Series (w/o Electronically Controlled Emissions)	ZGA735327,	International/Navistar
7310X	7.6L (466) Navistar Diesel (From 10/4/91) 2554, 2574, 2654, 2674, 8100, 8200, 8300	1815538C91	International/Navistar
7310X	7.6L (466) Navistar Diesel (From 10/4/91) 2554, 2574, 2654, 2674, 8100, 8200, 8300	735445C91	International/Navistar
7310X	7.6L (466) Navistar Diesel (From 10/4/91) 2554, 2574, 2654, 2674, 8100, 8200, 8300	ZGA735327,	International/Navistar
7311X	6.6L (401) B-C-CF-F800 (w/out Water Pump Mounted Fan)	F1HZ-8501CRM	Ford Truck
7311X	6.6L (401) C600/F800 Diesel (w/out Water Pump Mounted Fan, Exc. 210 H.P)	F1HZ-8501C	Ford Truck
7311X	6.6L (401) 7.8L (476) Diesel B-F-FT-L600/L900 (From 10/1/90) (w/out Water Pump Mounted Fan)	F1HZ-8501C	Ford Truck
7312X	Model 800, IHC Scout, Mail Truck	2930-073-3473	Government Postal Vehicles
7312X	Model CO/1600, IHC Scout, Mail Truck	2930-073-3473	Government Postal Vehicles
7312X	4 Cyl. 2.5L (152) (w/Auto Fan)	861236R92	International/Navistar
7312X	7.6L (466) Cab Over Models	680899C93	International/Navistar
7312X	5.6L (V345) Gas 1452, 1624, 1652, 1654, 1723, 1724, 1753, 1754, 1823, 1824, 1853, 1924, 1925, 1954, 1955, 2125 Models		International/Navistar



7312X	3.2L (196) (Models w/o Fan Clutch)	463365C91	International/Navistar
7312X	2.5L (152) (w/Auto Fan)	861236R92	International/Navistar
7312X	5.0L (304), 5.6L (345), 6.4L (392) (Models w/o Fan Clutch)	463365C91	International/Navistar
7312X	4.4L (266), 5.0L (304) (Models w/o Fan Clutch)	463365C91	International/Navistar
7312X	4.4L (266), 5.0L (304) (Models w/o Fan Clutch)	463365C91	International/Navistar
7312X	4.4L (266), 5.0L (304) (Models w/o Fan Clutch)	463365C91	International/Navistar
7312X	4.4L (266)	463365C91	International/Navistar
7312X	4.4L (266), 5.0L (304) (Models w/o Fan Clutch)	463365C91	International/Navistar
7312X	4.4L (266), 5.0L (304) (Models w/o Fan Clutch)	463365C91	International/Navistar
7312X	3.2L (196) (Models w/o Fan Clutch)	463365C91	International/Navistar
7312X	3.2L (196) w/Auto Fan	463365C91	International/Navistar
7312X	2.5L (152) w/Auto Fan	463365C91	International/Navistar
7312X	5.0L (304), 5.6L (345) (Models w/o Fan Clutch)	463365C91	International/Navistar
7312X	4.4L (266), 5.5L (304), 5.6L (345), 6.4L (392) (Models w/o Fan Clutch)	463365C91	International/Navistar
7312X	4.4L (266)	270918C92	International/Navistar
7313X	7.6L (466) Navistar Diesel 2554, 2574, 2654, 2674, 8100, 8200, 8300 Forward Control Series; 3600, 3700, 3800, 3900FC Bus Chassis Series	1817687C92	International/Navistar
7313X	7.6L (466) Navistar Diesel 2554, 2574, 2654, 2674, 8100, 8200, 8300 Forward Control Series; 3600, 3700, 3800, 3900FC Bus Chassis Series	1817687C96	International/Navistar
7313X	8.6L (530) Navistar Diesel 1400, 1452, 1600, Metro, 1652, 2554, 2654, 4500, 4600, 8200, 8300, Forward Control Series DT	1817687C94	International/Navistar
7314X	7.3L (466) (F) E250/350 Direct Injection Turbo Diesel	F5TZ-8501BRM	Ford Truck
7314X	7.3L (466) (F) E250/350 Direct Injection Turbo Diesel	F5TZ-8501CRM	Ford Truck
7314X	7.3L (466) (F) F250/350 Direct Injection Turbo Diesel	F5TZ-8501A, B, CRM	Ford Truck
7314X	7.3L (446) Direct Injection Turbo Diesel	F5TZ-8501BRM	Ford Truck
7314X	7.3L (446) Direct Injection Turbo Diesel	F5TZ-8501CRM	Ford Truck
7314X	7.3L (446) (F) Direct Injection Turbo Diesel	F5TZ-8501BRM	Ford Truck
7314X	7.3L (446) (F) Direct Injection Turbo Diesel	F5TZ-8501CRM	Ford Truck
7315X	7.3, T444E Bus/Truck Diesel	1823669C92	International/Navistar
7315X	DI-T444E Bus (7.3L)	182285102	International/Navistar
7315X	DI-T444E Bus (7.3L)	1823669C92	International/Navistar
7319X	6.6L (401) B-C-CF-F800 (With Water Pump Mounted Fan)	F1HZ-8501DRM	Ford Truck
7319X	6.6L (401) C600/F800 Diesel (With Water Pump Mounted Fan, Exc. 210 H.P)	F1HZ-8501D	Ford Truck
7319X	6.6L (401) 7.8L (476) Diesel B-F-FT-L600/L900 (From 10/1/90) (With Water Pump Mounted Fan) (Exc. 210 H.P)	F1HZ-8501D	Ford Truck
7320X	7.3L (446) (F) Direct Injection Turbo Diesel	F7TZ-8501BRM	Ford Truck
7320X	7.3L (446) (F) Direct Injection Turbo Diesel	F8IZ-8501ARM	Ford Truck
7320X	7.3L (446) (F) Direct Injection Turbo Diesel	F7TZ-8501CRM,	Ford Truck
7320X	7.3L (466) (F) E350 Direct Injection Turbo Diesel	F7TZ-8501BRM	Ford Truck
7320X	7.3L (466) (F) E350 Direct Injection Turbo Diesel	F8IZ-8501ARM	Ford Truck
7320X	7.3L (466) (F) E350 Direct Injection Turbo Diesel	F7TZ-8501CRM	Ford Truck
7320X	7.3L (466) (F) E250/350 Direct Injection Turbo Diesel	F7TZ-8501BRM	Ford Truck
7320X	7.3L (466) (F) E250/350 Direct Injection Turbo Diesel	F8IZ-8501ARM	Ford Truck
7320X	7.3L (466) (F) E250/350 Direct Injection Turbo Diesel	F7TZ-8501CRM	Ford Truck

7320X	7.3 (446) (F) Diesel	F7TZ-8501BRM	Ford Truck
7320X	7.3 (446) (F) Diesel	F8IZ-8501ARM	Ford Truck
7320X	7.3 (446) (F) Diesel	F7TZ-8501CRM,	Ford Truck
7320X	7.3L (466) (F) F250/350 Direct Injection Turbo Diesel	F7TZ-8501BRM	Ford Truck
7320X	7.3L (466) (F) F250/350 Direct Injection Turbo Diesel	F8IZ-8501ARM	Ford Truck
7320X	7.3L (466) (F) F250/350 Direct Injection Turbo Diesel	F7TZ-8501CRM	Ford Truck
7320X	7.3L (446) (F) Direct Injection Turbo Diesel	F7TZ-8501BRM	Ford Truck
7320X	7.3L (446) (F) Direct Injection Turbo Diesel	F8IZ-8501ARM	Ford Truck
7320X	7.3L (446) (F) Direct Injection Turbo Diesel	F7TZ-8501CRM	Ford Truck
7321X	DT466 & 530E New Generation (7.6L)	1842664C92	International/Navistar
7321X	DT466 & 530E New Generation (7.6L)	1841764C2	International/Navistar
7321X	DT466 & 530E New Generation (7.6L)	1830607C4	International/Navistar
7321X	DT466 & 530E New Generation (7.6L)	184664C92	International/Navistar
7322X	F650/750	YC3Z-8501A	Ford Truck
7322X	7.3, T444E Bus/Truck Diesel	YC3Z-8501A	International/Navistar
7323X	6.0L Powerstroke, Turbo Diesel	3C3Z-8501ABRM	Ford Truck
7323X	6.0L (V8) Diesel, F650, F750	4C4Z-8501AARM	Ford Truck
7324X	6.0L Diesel, E Series, F Series	4C3Z-8501ABRM	Ford Truck
7325X	SP-375 Windrower w/C175	303395R91	International/Harvester
7325X	SP-375 Windrower w/C175	601816C91	International/Harvester
7325X	SP-315 w/D236	303395R91	International/Harvester
7325X	SP-315 w/D236	601816C91	International/Harvester
7325X	SP-616, 622 Cotton Picker w/C301	303395R91	International/Harvester
7325X	SP-616, 622 Cotton Picker w/C301	601816C91	International/Harvester
7325X	SP-205, 315w/C221	303395R91	International/Harvester
7325X	SP-205, 315w/C221	601816C91	International/Harvester
7325X	SP-403 w/C263, C282, D282 (To Serial # 2195)	303395R9	International/Harvester
7325X	SP-403 w/C263, C282, D282 (To Serial # 2195)	601816C91	International/Harvester
7325X	SP-303 w/C221 (From Serial # 7278)	303395R91	International/Harvester
7325X	SP-303 w/C221 (From Serial # 7278)	601816C91	International/Harvester
7325X	SP-503 w/D301	303395R91	International/Harvester
7325X	SP-503 w/D301	601816C91	International/Harvester
7325X	100C LDR	601816C92	International/Harvester
7325X	3600A w/C263	601816C92	International/Harvester
7325X	D50, w/C301, H-50, A, B, C, w/D188, UD236, UD282, D301	601816C92	International/Harvester
7325X	H-50, A, B, C, w/D188, UD236, UD282, D301	601816C92	International/Harvester
7325X	9000 w/C291, C301	601816C92	International/Harvester
7325X	3800, 3850 w/C263	601816C92	International/Harvester
7325X	H-60B w/C301	601816C92	International/Harvester
7325X	TD9B & 150 LDR	601816C92	International/Harvester
7325X	2500 Consall	601816C92	International/Harvester
7325X	T & TD7	601816C92	International/Harvester
7325X	2656 w/C263 & 3616 w/C221	601816C92	International/Harvester
7325X	4 Cyl. Gas 504, 2504 Models	303395R91	International/Harvester
7325X	6 Cyl. Gas 856, 2856 Models & 6 Cyl. Power Units UC221, 263, 291, UD188, 236, 282	303395R91	International/Harvester
7325X	2706 w/C263, 291, 2756 w/C291, 2856 w/C301, H-25 PL w/D188, H-30 w/236, 282, H-40 w/V264-6A, TD62 w/263	601816C92	International/Harvester
7325X	Farmall 460 Diesel	303395R91	International/Harvester
7325X	Farmall 460, 560, 660 Gas Models	303395R91	International/Harvester

7325X	Models: H70, H86, 2606, 2706, 2756, 403, 460, 560, 606, 660, 706, 766, 806, 826, 856	601816C92	International/Harvester
7325X	BC160 To 180 Series, D301 Diesel B	318119R92	International/Navistar
7325X	BC160 To 180 Series, D301 Diesel B	303395R92	International/Navistar
7326X	3.2L (196) (Models w/Fan Clutch)	357621C92	International/Navistar
7326X	5.0L (304), 5.6L (345), 6.4L (392) (Models w/Fan Clutch)	357621C92	International/Navistar
7326X	4.4L (266), 5.0L (304) (Models w/Fan Clutch)	357621C92	International/Navistar
7326X	4.4L (266), 5.0L (304) (Models w/Fan Clutch)	357621C92	International/Navistar
7326X	4.4L (266), 5.0L (304) (Models w/Fan Clutch)	357621C92	International/Navistar
7326X	4.4L (266), 5.0L (304) (Models w/Fan Clutch)	357621C92	International/Navistar
7326X	4.4L (266), 5.0L (304) (Models w/Fan Clutch)	357621C92	International/Navistar
7326X	3.2L (196) (Models w/ Fan Clutch)	357621C92	International/Navistar
7326X	5.0L (304), 5.6L (345) (Models w/Fan Clutch)	357621C92	International/Navistar
7326X	4.4L (266), 5.5L (304), 5.6L (345), 6.4L (392) (Models w/o Fan Clutch)	357621C92	International/Navistar
7330X	All 2000 thru 7000 Series Gas or Diesel (w/Single Groove Pulley & 4.100" Impeller)	D5NN-8501E	Ford Tractor & Industrial
7330X	All 2000 thru 7000 Series Gas or Diesel (w/Single Groove Pulley & 4.100" Impeller)	C5NN-8501E	Ford Tractor & Industrial
7330X	All 2000 thru 7000 Series Gas or Diesel (w/Single Groove Pulley & 4.100" Impeller)	D5NN-8501E	Ford Tractor & Industrial
7331X	2000, 3000, 4000 Series Gas or Diesel (w/Single Groove Pulley & 3.500 Dia. Impeller)	C5NN-8501A	Ford Tractor & Industrial
7331X	2000, 3000, 4000 Series Gas or Diesel (w/Single Groove Pulley & 3.500 Dia. Impeller)	D5NE-8501A	Ford Tractor & Industrial
7331X	5000 Gas or Diesel (w/Single Groove Pulley & 3.500 Dia. Impeller) (Can Use 7330X)	C5NN-8501A	Ford Tractor & Industrial
7331X	5000 Gas or Diesel (w/Single Groove Pulley & 3.500 Dia. Impeller) (Can Use 7330X)	D5NE-8501A	Ford Tractor & Industrial
7332X	134, 172, 192 Gas or Diesel	D1JJ-8501C	Ford Tractor & Industrial
7333X	Models (5110, 5610, 6610, 6810, 7410, 7610, 7710 All 11/88 & Up) 7010 4/96 & UP (All w/Threaded 2 Belt Pulley)	FAPN-8A513AA	Ford Tractor & Industrial
7334X	134, 172 Tractor & Industrial gas Models 600, 700, 800, 900, 2000, 4000 Series Diesel Models	CDPN-8501C	Ford Tractor & Industrial
7334X	134, 172 Tractor & Industrial gas Models 600, 700, 800, 900, 2000, 4000 Series Diesel Models	EAF-8501C	Ford Tractor & Industrial
7334X	Series 500D, 501D, After Serial #153775; 600D, 601D, 700D, 701D, 2030D, 2031D, 2110D, 2111D, 2120D, 2130D, 2131D w/144 Diesel	CDPN-8501C	Ford Tractor & Industrial
7334X	Series 500D, 501D, After Serial #153775; 600D, 601D, 700D, 701D, 2030D, 2031D, 2110D, 2111D, 2120D, 2130D, 2131D w/144 Diesel	EAF-8501C	Ford Tractor & Industrial
7334X	Series 800D, 801D, 900D, 901D, 1800, 4030D, 4031D, 4040D, 4110D, 4120D, 4121D, 4130D, 4131D, 4140D w/D172 Diesel	CDPN-8501C	Ford Tractor & Industrial
7334X	Series 800D, 801D, 900D, 901D, 1800, 4030D, 4031D, 4040D, 4110D, 4120D, 4121D, 4130D, 4131D, 4140D w/D172 Diesel	EAF-8501C	Ford Tractor & Industrial
7334X	Series 800, 801, 900, 901, 1800, 1801, 4030, 4031, 4040, 4110, 4121, 4130, 4131, 4140 w/172 Gas or L.P.G	CDPN-8501C	Ford Tractor & Industrial

7334X	Series 800, 801, 900, 901, 1800, 1801, 4030, 4031, 4040, 4110, 4121, 4130, 4131, 4140 w/172 Gas or L.P.G	EAF-8501C	Ford Tractor & Industrial
7334X	Series NAA, 501, 541, 600, 601, 611, 620, 621, 630, 631, 640, 641, 650, 651, 660, 661, 671, 700, 701, 740, 741, 771, 2030, 2031, 2110, 2111, 2120, 2130, 2131 w/134 Gas or L.P.G.	CDPN-8501C	Ford Tractor & Industrial
7334X	Series NAA, 501, 541, 600, 601, 611, 620, 621, 630, 631, 640, 641, 650, 651, 660, 661, 671, 700, 701, 740, 741, 771, 2030, 2031, 2110, 2111, 2120, 2130, 2131 w/134 Gas or L.P.G.	EAF-8501C	Ford Tractor & Industrial
7334X	Series NAA, 600, 620, 621, 630, 631, 640, 641, 650, 651, 660, 661, 700, 740, 741 w/134 Kerosene Eng.	CDPN-8501C	Ford Tractor & Industrial
7334X	Series NAA, 600, 620, 621, 630, 631, 640, 641, 650, 651, 660, 661, 700, 740, 741 w/134 Kerosene Eng.	EAF-8501C	Ford Tractor & Industrial
7334X	800K, 900K w/172 Kerosene Eng.	CDPN-8501C	Ford Tractor & Industrial
7334X	800K, 900K w/172 Kerosene Eng.	EAF-8501C	Ford Tractor & Industrial
7335X	Model 2N, 8N, 9N	2N-8501	Ford Tractor & Industrial
7335X	Model 2N, 8N, 9N	9N-8501	Ford Tractor & Industrial
7335X	Model 2N, 8N, 9N	8N-8501	Ford Tractor & Industrial
7336X	4.9L (300) Industrial Eng.	F6JE-8501BA	Ford Tractor & Industrial
7337X	8000, 8200, 8400	C9NN-8501B	Ford Tractor & Industrial
7337X	8000, 8200, 8400	DHPN-8A513B	Ford Tractor & Industrial
7337X	9000, 9200	C9NN-8501B	Ford Tractor & Industrial
7337X	9000, 9200	DHPN-8A513B	Ford Tractor & Industrial
7338X	NAA, Major	CDPN-8501B	Ford Tractor & Industrial
7339X	4310, 4610, 4810, 39 Series (Larger Mounting Holes Than 7331X) (Has Larger Bearing)	N/A	Ford Tractor & Industrial
7340X	2000, 3000, 4000, 5000, 7000 (2600, 3600, 4100, 4600, 5600, 5700, 6600, 6700, 7600, 7700 (2310, 2610, 2810, 2910, 3610, 3910, 4110, 4610 All 2/90) w/5/16" & 7/16" Mounting Holes (2 Groove Pulley) (Large Bearing)	EAPN-8A513A	Ford Tractor & Industrial
7340X	2000, 3000, 4000, 5000, 7000 (2600, 3600, 4100, 4600, 5600, 5700, 6600, 6700, 7600, 7700 (2310, 2610, 2810, 2910, 3610, 3910, 4110, 4610 All 2/90) w/5/16" & 7/16" Mounting Holes (2 Groove Pulley) (Large Bearing)	EGPN-8A513CA	Ford Tractor & Industrial
7341X	6700 Thru 7700 w/5/16" & 3/8" Mounting Holes, Same as 7340 Except has Smaller Mounting Holes	FAPN-8A513AD3	Ford Tractor & Industrial
7350X	C201PT (2.2) Diesel, Refrigeration Unit	11 4576	Isuzu Industrial
7350X	Isuzu 2.2L C201, C201PT, Refrigeration Unit	11-4576	Thermo King
7351X	2.2L Direct Injection, w/Auxiliary Port	11-5858, T-K4576	Thermo King
7352X	2.2L Direct Injection, w/out Auxiliary Port	11-5858	Thermo King
7353X		8-94391-670-5	Isuzu Industrial
7354X	5.7L (350)	8-12524-498-0	Isuzu Industrial
7500X	Volvo D12C, V12	20431135, 20713787, 20734268	Volvo
7400X	Model ATEGO (OM904)	940 200 04 01	Mercedes-Benz
7401X	Model U3000, U5000, OM900, OM906	906 200 48 01	Mercedes-Benz
7401X	Model U3000, U5000, OM900, OM906	A906 200 1301	Mercedes-Benz
7401X	Model U3000, U5000, OM900, OM906	A906 200 4801	Mercedes-Benz
7401X	Model U3000, U5000, OM900, OM906	A906 200 2001	Mercedes-Benz
7401X	Model U3000, U5000, OM900, OM906	A906 200 1401	Mercedes-Benz

7901X	Tall Housing	N/A	Hino Truck
9160X	60 Series, Accessory Drive, w/2 Belt Pulley	23509200	Detroit Diesel Accessory Drives
9161X	60 Series, Accessory Drive, w/Multi Groove Pulley	23509201	Detroit Diesel Accessory Drives
9162X	60 Series, Accessory Drive, w/out Pulley	23509200	Detroit Diesel Accessory Drives
RE500737	For Models: 5410, 5420, 5510, 5520	N/A	John Deere

<b>Casting Number</b>	<b>Application/ Engine</b>	<b>BEPCO PART NUMBER</b>	<b>Make</b>
115481	H, HF, HR, HRS, NFT, NRT, NRTO, NH220, NHE180, NHE195, NHE220, NHS, NHRS (w/High Mounted Fan) (w/out Pulley) ( Right Hand Mounted Pump)	7077X	Cummins Diesel
115481	H, HF, HR, HRS, NFT, NRT, NRTO, NH220, NHE180, NHE195, NHE220, NHS, NHRS (w/Pulley) ( Right Hand Mounted Pump)	7077PX	Cummins Diesel
132423	H, HF, HR, HRS, NFT, NRT, NRTO, NH220, NHE180, NHE195, NHE220, NHS, NHRS (w/High Mounted Fan) (w/out Pulley) ( Right Hand Mounted Pump)	7077X	Cummins Diesel
132423	H, HF, HR, HRS, NFT, NRT, NRTO, NH220, NHE180, NHE195, NHE220, NHS, NHRS (w/Pulley) ( Right Hand Mounted Pump)	7077PX	Cummins Diesel
132423	Models using Cummins Diesel Straight Eng. NH-180, NH-195, NH-200, NH220 and White Auto Car (Right Hand Pump)	7077X	White Truck and White Autocar
115498	220, NHT, NHRS, w/5 1/8" Bore	7047X	Cummins Diesel
165135	220, NHT, NHRS, w/5 1/8" Bore	7047X	Cummins Diesel
165135	220, NRT, NROT, w/5 1/8" Bore	7048X	Cummins Diesel
196830	NT & NTC 250 5 1/2" Bore & 9 1/4" Shaft	7054X	Cummins Diesel
196830	NT & NTC 250 5 1/2" Bore & 9 7/8" Shaft	7055X	Cummins Diesel
196845	NH, NT & NTC Non FCC, NH230, NH250, NHC270, NHE225 Diesel, NT280, NT300 , NT310, NT335, NT380, NTA380, NTC335, NTC350, NTC380, (Non FCC) w/2 belt Pulley	7053X	Cummins Diesel
196845	NH, NT & NTC Non FCC, NH230, NH250, NHC270, NHE225 Diesel, NT280, NT300 , NT310, NT335, NT380, NTA380, NTC335, NTC350, NTC380, (Non FCC) w/out Pulley	7065X	Cummins Diesel
196845	Models using Cummins Diesel Straight Eng. NH-250, NHE-225 (High Mounted Fan), NT-280, NT-300, NT-380 (Right Hand Pump)	7065X	White Truck and White Autocar
196930	w/3 Belt Pulley	7056X	Cummins Diesel
202963	NH 250 Military (5 1/2" Bore Shaft) w/pulley	7080X	Cummins Diesel
206864	KT/KTA 1150	7040X	Cummins Diesel
206964	KT/KTA 1150	7040X	Cummins Diesel
208118	2 Groove Idler Pulley	7058X	Cummins Diesel
210238	Big Cam	7044X	Cummins Diesel
210238	Cummins 4000 (14.0)	7044X	Cummins Diesel
210238	Small Cam FFC, w/4 11/16" Multi Groove Pulley & 4" Impeller	7049X	Cummins Diesel
210238	NTC270-CT, NT855-C280, NTC290, NTC290-R, NTC855-C310, NT310, NTC350, NTA855-C360	7051X	Cummins Diesel
215397	Big Cam, Multi Groove Idler Pulley	7059X	Cummins Diesel
218274	Small Cam w/2 Groove Pulley & 4 1/2" Impeller	7050X	Cummins Diesel
218274	NTC290, NTC350, NTC400, Formula 290, 350 (Suitcase Pump) w/4 11/16" Multi Groove Pulley & 4 1/2" Impeller, Vented	7052X	Cummins Diesel
218274	NTC300, 350, 400: Formula 300, 350, 400, 475 (Suitcase Pump) w/4 11/16" Multi Groove Pulley & 4" Impeller	7061X	Cummins Diesel
219040	Big Cam, 4 11/16" Pulley & 4 1/2" Impeller, w/7 Hole Casting, Can use 7052	7042X	Cummins Diesel

219040	NTC270-CT, NT855-C280, NTC290, NTC290-R, NTC855-C310, NT310, NTC350, NTA855-C360	7051X	Cummins Diesel
330813	5.7L (350), Series 40, 50, 60	7146X	Chevrolet Truck
330813	5.7L (350), Series 40, 50, 60	7146X	GMC Truck
352199	4.8L (292), Series 50, 60, 2nd Design	7143X	Chevrolet Truck
352199	4.8L (292), Series 50, 60, 2nd Design	7143X	GMC Truck
465802	4.8L (292), P4 Series	7143X	Chevrolet Truck
465802	4.8L (292), Series 50, 60	7143X	Chevrolet Truck
465802	4.8L (292), Series 50, 60, School Bus	7143X	Chevrolet Truck
465802	4.8L (292), P4 Series	7143X	GMC Truck
465802	4.8L (292), Series 50, 60	7143X	GMC Truck
465802	4.8L (292), Series 50, 60, School Bus	7143X	GMC Truck
5117921	V-6 & V-8 Engines, Non Turbo, Standing Pump w/2 Outlets pointing straight Down, Standard Capacity (w/Bolt on Back Cover)	7105X	Detroit Diesel
553928	V, VT 555, V8	7070X	Cummins Diesel
555260	Dina w/front engine 155 6cyl & 210 8cyl	7043X	Cummins Diesel
555260	Dina w/Rear engine 155 6cyl & 210 8cyl	7045X	Cummins Diesel
910416	3.2L (198) 3.7L (225)	7086X	Dodge Trucks
910416	2.8L (170), 3.2L (198) 3.7L (225)	7086X	Dodge Trucks
910416	3.7L (225)	7086X	Dodge Trucks
910416	3.7L (225)	7086X	Dodge Trucks
910416	3.2L (198), 3.7L (225) Series 400 Thru 600	7086X	Dodge Trucks
910416	2.8L (170), 3.7L (225) D400, 500; P400; S400, 500; L600	7086X	Dodge Trucks
1543945	3306 Angled Teeth w/Off Set Holes & 3 1/8" Bearing	7007X	Caterpillar
1543945	3306 Straight Teeth w/Off Set Holes	7007GX	Caterpillar
2128284	2.8L (170), 3.7L (225)	7086X	Dodge Trucks
2128284	2.8L (170), 3.2L (198) 3.7L (225)	7086X	Dodge Trucks
2128284	3.7L (225)	7086X	Dodge Trucks
2128284	3.7L (225)	7086X	Dodge Trucks
2128284	3.7L (225)	7086X	Dodge Trucks
2128284	3.7L (225)	7086X	Dodge Trucks
2128284	3.2L (198), 3.7L (225) Series 400 Thru 600	7086X	Dodge Trucks
2128284	2.8L (170), 3.7L (225) D400, 500; P400; S400, 500; L600	7086X	Dodge Trucks
2128284	205, 300 Self-Propelled Gas	7086	Massey-Ferguson, Massey-Harris
2863063	2.8L (170), 3.7L (225)	7086X	Dodge Trucks
2863063	3.2L (198) 3.7L (225)	7086X	Dodge Trucks
2863063	2.8L (170), 3.2L (198) 3.7L (225)	7086X	Dodge Trucks
2863063	3.7L (225)	7086X	Dodge Trucks
2863063	3.7L (225)	7086X	Dodge Trucks
2863063	3.7L (225)	7086X	Dodge Trucks
2863063	3.2L (198), 3.7L (225) Series 400 Thru 600	7086X	Dodge Trucks
2863063	2.8L (170), 3.7L (225) D400, 500; P400; S400, 500; L600	7086X	Dodge Trucks
2863063	205, 300 Self-Propelled Gas	7086	Massey-Ferguson, Massey-Harris
2883663	2.8L (170), 3.2L (198) 3.7L (225)	7086X	Dodge Trucks
2883663	2.8L (170), 3.2L (198) 3.7L (225)	7086X	Dodge Trucks
2883663	3.7L (225)	7086X	Dodge Trucks
2883663	3.7L (225)	7086X	Dodge Trucks
2883663	3.7L (225)	7086X	Dodge Trucks
2883663	3.2L (198), 3.7L (225) Series 400 Thru 600	7086X	Dodge Trucks
2883663	2.8L (170), 3.7L (225) D400, 500; P400; S400, 500; L600	7086X	Dodge Trucks
2883663	205, 300 Self-Propelled Gas	7086	Massey-Ferguson, Massey-Harris
3002520	NTC Formula 230 (Short Suitcase w/2 Groove Pulley & 4" Impeller)	7057X	Cummins Diesel



3002520	NTC Formula 230, (Short Suitcase w/4 11/16" Multi Groove Pulley & 4" Impeller)	7062X	Cummins Diesel
3004745	4 11/16" Multi Groove Pulley & 4 1/2" Impeller	7041X	Cummins Diesel
3030489	KT/KTA 1710, 2300	7079X	Cummins Diesel
3030490	KT/KTA 1710, 2300	7079X	Cummins Diesel
3035157	LTA10, 240, 270, 300, w/4 hole Mount up to 1991	7066X	Cummins Diesel
3039182	LTA10, 240, 270, 300, w/4 hole Mount up to 1991	7066X	Cummins Diesel
3045163	Ford LTL9000, GMC Brigadier (Suitcase Pump) (5 1/2 Bore) (Not Suitable for Horizontal Eng.s.) w/4 11/16" Multi Groove Pulley & 4 1/2" Impeller, Vented	7075X	Cummins Diesel
3060884	Multi Groove Idler Pulley	7067X	Cummins Diesel
3062899	NTC-300, 315, 350, 365, 400, w/Multi Groove Pulley	7060X	Cummins Diesel
3069644	310, 330, 350, 370, 410 w/Multi Groove Pulley	7068X	Cummins Diesel
3076523	310, 330, 350, 370, 410 w/Multi Groove Pulley	7068X	Cummins Diesel
3283602	B Series, ISB, 3.9L 4cyl, 5.9L 6cyl. New Style Pulley w/out lip	7063X	Cummins Diesel
3804024	N14 - Volvo	7081X	Cummins Diesel
3859326	510 Self-Propelled Gas	7090	Massey-Ferguson, Massey-Harris
3882615	L-10E-MTA 11-330E w/3 Hole Mount, Long Shaft	7072X	Cummins Diesel
3882615	ISM, M11 w/3 Hole Mount, Short Shaft	7072SSX	Cummins Diesel
3903357	B Series, ISB, 3.9L 4cyl, 5.9L 6cyl. New Style Pulley w/out lip	7063X	Cummins Diesel
3903357	B Series, 3.9L 4cyl, 5.9L 6cyl. Old Style Pulley w/lip	7063AX	Cummins Diesel
3903357	In-Line 6 Cyl.	7076X	Cummins Diesel
3903357	5.9L (360) Cummins Turbo Diesel	7063X	Dodge Trucks
3913439	In-Line 6 Cyl.	7076X	Cummins Diesel
3940052	ISC & ISL series, Similar to 7076 except has Larger Casting at Mount w/Larger Impeller.	7082X	Cummins Diesel
4095700	3.2L (198) 3.7L (225)	7086X	Dodge Trucks
4095700	2.8L (170), 3.2L (198) 3.7L (225)	7086X	Dodge Trucks
4095700	3.7L (225)	7086X	Dodge Trucks
4095700	3.7L (225)	7086X	Dodge Trucks
4095700	3.2L (198), 3.7L (225) Series 400 Thru 600	7086X	Dodge Trucks
4095700	2.8L (170), 3.7L (225) D400, 500; P400; S400, 500; L600	7086X	Dodge Trucks
4104553	3.2L (198) 3.7L (225)	7086X	Dodge Trucks
4104553	2.8L (170), 3.2L (198) 3.7L (225)	7086X	Dodge Trucks
4104553	3.7L (225)	7086X	Dodge Trucks
4104553	3.7L (225)	7086X	Dodge Trucks
4104553	3.2L (198), 3.7L (225) Series 400 Thru 600	7086X	Dodge Trucks
4104553	2.8L (170), 3.7L (225) D400, 500; P400; S400, 500; L600	7086X	Dodge Trucks
5101162	V-6 & V-8 Engines, Running Pump w/2 Outlets at 45 Degree Angles in Opposite Directions, w/Snap Ring Back Cover	7110X	Detroit Diesel
5101802	V-6 & V-8 Engines, Walking Pump w/1 Outlet pointing straight down & 1 Outlet at 45 Degree Angle, w/Bolt on Back Cover	7111X	Detroit Diesel
5106160	V-6 & V-8 Engines, Turbo, Standing Pump w/2 Outlets pointing straight Down, High Capacity (w/Bolt on Back Cover)	7107X	Detroit Diesel
5106180	V-6 & V-8 Engines, Non Turbo, Standing Pump w/2 Outlets pointing straight Down, Standard Capacity (w/Bolt on Back Cover)	7105X	Detroit Diesel
5106180	V-6 & V-8 Engines, Turbo, Standing Pump w/2 Outlets pointing straight Down, High Capacity (w/Bolt on Back Cover)	7107X	Detroit Diesel

5135455	V-6 & V-8 Engines, Turbo, Standing Pump w/2 Outlets pointing straight Down, High Capacity (w/Bolt on Back Cover)	7107X	Detroit Diesel
5135455	V-8 Engines, Turbo, Standing Pump w/2 Outlets pointing straight Down, High Capacity (w/Reverse Gear & Bolt on Back Cover)	7118X	Detroit Diesel
5135601	HD-5 Diesel Left Hand (2 cyl)	7103X	Allis Chalmers
5135601	HD-7 Diesel Left Hand (3 cyl)	7103X	Allis Chalmers
5135601	HD-7 Diesel Left Hand (6 cyl)	7103X	Allis Chalmers
5135601	Titan 90 Series w/54 BBC 6V-92T, 6V-92TT, 8V-92T Diesel Eng. Left Hand Mount	7103X	Chevrolet Truck
5135601	Series 50, 60, 65 w/6-71 Diesel Eng. Left Hand Mount	7103X	Chevrolet Truck
5135601	3, 4, 6 Cyl. In Line Engs. (Exc. Turbo) (Left Hand Pump)	7103X	Detroit Diesel
5135601	Series 50, 60, 65 w/6-71 Diesel Eng. Left Hand Mount	7103X	GMC Truck
5135602	HD-5 Diesel Right Hand (2 cyl)	7104X	Allis Chalmers
5135602	HD-7 Diesel Right Hand (3 cyl)	7104X	Allis Chalmers
5135602	Titan 90 Series w/54 BBC 6-71 Diesel Eng. Right Hand Mount	7104X	Chevrolet Truck
5135602	Series 50, 60, 65 w/6-71 Diesel Eng. Right Hand Mount	7104X	Chevrolet Truck
5135602	Series 90 w/6-71 Diesel Eng.	7104X	Chevrolet Truck
5135602	3, 4, 6 Cyl. In Line Engs. (Exc. Turbo) (Right Hand Pump)	7104X	Detroit Diesel
5135602	Series 50, 60, 65 w/6-71 Diesel Eng. Right Hand Mount	7104X	GMC Truck
5135602	450-900 Series, 3-71, 4-71, 6-71, Diesel Eng. Exc. 6-71T, Right Hand Pump.	7104X	GMC Truck
5136455	V-6 & V-8 Engines, Non Turbo, Standing Pump w/2 Outlets pointing straight Down, Standard Capacity (w/Bolt on Back Cover)	7105X	Detroit Diesel
5136455	V-6 & V-8 Engines, Turbo, Standing Pump w/2 Outlets pointing straight Down, High Capacity (w/Bolt on Back Cover)	7107X	Detroit Diesel
5140009		7125	Detroit Diesel
5142273	V-6 & V-8 Engines, Non Turbo, Running Pump w/2 Outlets at 45 Degree Angles in Opposite Directions, Standard Capacity (w/ Bolt on Back Cover)	7106X	Detroit Diesel
5142273	V-8 Engines, Turbo, Running Pump w/2 Outlets at 45 Degree Angles in Opposite Directions, High Capacity (w/Bolt on Back Cover)	7108X	Detroit Diesel
5142273	V-8 Engines, Turbo, Running Pump w/2 Outlets at 45 Degree Angles in Opposite Directions, High Capacity (w/Reverse Gear & Bolt on Back Cover)	7115X	Detroit Diesel
5144688	Left Hand	7101X	Detroit Diesel
5144689	Right Hand	7102X	Detroit Diesel
5145089	Standing, w/bolt on Back Cover & w/Heater Provision	7112X	Detroit Diesel
5149707	3, 4, 6 Cyl. In Line Engs. (Exc. Turbo) (Right Hand Pump)	7104X	Detroit Diesel
5178317	3, 4, 6 Cyl. In Line Engs. (Exc. Turbo) (Left Hand Pump)	7103X	Detroit Diesel
5178318	Right Hand	7102X	Detroit Diesel
5178318	3, 4, 6 Cyl. In Line Engs. (Exc. Turbo) (Right Hand Pump)	7104X	Detroit Diesel
5182069	In-Line A & B Engs. Turbo (Left Hand) High Capacity	7113X	Detroit Diesel
5182070	In-Line A & B Engs. Turbo (Right Hand) High Capacity	7114X	Detroit Diesel
6106160	V-6 & V-8 Engines, Non Turbo, Standing Pump w/2 Outlets pointing straight Down, Standard Capacity (w/Bolt on Back Cover)	7105X	Detroit Diesel
8828804	8 Cyl. Diesel, w/Heater Outlet Provision	7120X	Detroit Diesel
8920383	8 Cyl. Diesel, w/Out Heater Outlet Provision	7119X	Detroit Diesel
8920925	3, 4, 6 Cyl. In Line Engs. (Exc. Turbo) (Right Hand Pump)	7104X	Detroit Diesel

8921099	V-6 & V-8 Engines, Running Pump w/2 Outlets at 45 Degree Angles in Opposite Directions, w/Snap Ring Back Cover	7110X	Detroit Diesel
8921100	V-6 & V-8 Engines, Walking Pump w/1 Outlet pointing straight down & 1 Outlet at 45 Degree Angle, w/Snap Ring Back Cover	7109X	Detroit Diesel
8921100	V-6 & V-8 Engines, Walking Pump w/1 Outlet pointing straight down & 1 Outlet at 45 Degree Angle, w/Snap Ring Back Cover & Reverse Gear	7124X	Detroit Diesel
8922325	V-6 & V-8 Engines, Walking Pump w/1 Outlet pointing straight down & 1 Outlet at 45 Degree Angle, w/Snap Ring Back Cover	7109X	Detroit Diesel
8922325	V-6 & V-8 Engines, Walking Pump w/1 Outlet pointing straight down & 1 Outlet at 45 Degree Angle, w/Snap Ring Back Cover & Reverse Gear	7124X	Detroit Diesel
8924657	8 Cyl. Diesel, w/Out Heater Outlet Provision	7119X	Detroit Diesel
8929511	Front Mount, Before 12/90	7121X	Detroit Diesel
10108457	5.7L (350)	7354	Isuzu Industrial
10241634	6.0L (366), 7.0L (427) B7 School Bus, C5, C6, C7 Series w/Screw on Hub	7123X	Chevrolet Truck
10241634	6.0L (366), F6, 7 Series w/Screw on Hub	7123X	Chevrolet Truck
10241634	6.0L (366), 7.0L (427) P6 School Bus, 50, 60, 70 Series w/Screw on Hub	7123X	Chevrolet Truck
10241634	6.0L (366) (P) , 7.0L (427) (M) B7 School Bus (C5, C6 C7 Series)	7123X	GMC Truck
10241634	6.0L (366) (P) F6, 7 Series	7123X	GMC Truck
10241634	6.0L (366) (P) , 7.0L (427) (M) B7& P6 School Bus (50, 60, 70 Series w/Screw on Hub)	7123X	GMC Truck
12557071	6.5L (395), B7 School Bus	7129X	Chevrolet Truck
12557071	6.5L (395), B7 School Bus, Exc. Hazard Warning Switch	7129X	Chevrolet Truck
12558870	8.1L, C6, C7, Kodiak, B7 School Bus	7144X	Chevrolet Truck
14001939	6.0L (366), 7.0L (427) B7 School Bus, C5, C6, C7 Series w/Screw on Hub	7123X	Chevrolet Truck
14001939	6.0L (366), F6, 7 Series w/Screw on Hub	7123X	Chevrolet Truck
14001939	6.0L (366), 7.0L (427) P6 School Bus, 50, 60, 70 Series w/Screw on Hub	7123X	Chevrolet Truck
14001939	6.0L (366), 7.0L (427) School Bus, 60, 70 Series w/Screw on Hub	7116X	Chevrolet Truck
14001939	7.4L (454), Series 60, 70	7116X	Chevrolet Truck
14001939	6.0L (366), 7.0L (427), 7.4L (454), 60 & 70 Series	7116X	GMC Truck
14001939	6.0L (366), 7.0L (427) 50, 60, 70 Series, School Bus	7123X	GMC Truck
14024206	6.2L (379) C, J Diesel,	7117X	GMC Truck
23505018	Front Mount, Before 12/90	7121X	Detroit Diesel
23505894	Rear Mount, After 12/90 (w/ 1/4" Pipe Port)	7122X	Detroit Diesel
23509201	60 Series, Accessory Drive, w/2 Belt Pulley	9160X	Detroit Diesel Accessory Drives
23509201	60 Series, Accessory Drive, w/Multi Groove Pulley	9161X	Detroit Diesel Accessory Drives
23509201	60 Series, Accessory Drive, w/out Pulley	9162X	Detroit Diesel Accessory Drives
23516416	Rear Mount, After 12/90 (w/ 1/4" Pipe Port)	7122X	Detroit Diesel
23517027	w/6 Vane Impeller, High Capacity (3/8" Pipe Port)	7126X	Detroit Diesel
23517027	w/6 Vane Impeller, High Capacity (3/8" Pipe Port) w/Steel Back Plate	7126SX	Detroit Diesel
23522721	w/6 Vane Impeller, High Capacity, Kangaroo Pouch.	7127X	Detroit Diesel
23523998	60 Series Accessory Drive	9163X	Detroit Diesel Accessory Drives
23524001	60 Series Accessory Drive	9163X	Detroit Diesel Accessory Drives
23530427	EGR, 14L	7141X	Detroit Diesel
23530429	EGR, 14L	7142X	Detroit Diesel

37711331	MF-135, MF-150, MF-2135, Using Perkins Diesel Eng.	7088	Massey-Ferguson, Massey-Harris
37711331	MF-35, MF-50, MF203, MF-205, Using Perkins Diesel Eng.	7089	Massey-Ferguson, Massey-Harris
37711331	Engine AD3-153	7088	Perkins Engine Heavy Duty
37711331	Engines 3A-152	7089	Perkins Engine Heavy Duty
38399175	510 Self-Propelled Gas	7090	Massey-Ferguson, Massey-Harris
53020135	3.9L (239)	7087X	Dodge Trucks
53020135	5.2L (318), 5.9L (360)	7087X	Dodge Trucks
53020135	3.9L (239)	7087X	Dodge Trucks
53020135	5.2L (318), 5.9L (360)	7087X	Dodge Trucks
53020135	3.9L (239)	7087X	Dodge Trucks
53020135	5.2L (318), 5.9L (360)	7087X	Dodge Trucks
53020135	3.9L (239)	7087X	Dodge Trucks
53020135	5.2L (318), 5.9L (360)	7087X	Dodge Trucks
53020135	5.2L (318), 5.9L (360)	7087X	Dodge Trucks
53020135	3.9L (239)	7087X	Dodge Trucks
53020135	5.2L (318), 5.9L (360)	7087X	Dodge Trucks
100-7479	3406E w/Dome Gear & Curved Teeth	7006EX	Caterpillar
102-5946	3406E w/Dome Gear & Curved Teeth	7006EX	Caterpillar
103-0745	3176 Aluminum Casting	7009X	Caterpillar
105-4213	3176B, C10, C12, C13 Acert Cast Iron Housing	7011X	Caterpillar
105-4214	3176B, C10, C12, C13 Acert Cast Iron Housing	7011X	Caterpillar
135-4918	3406E w/Dome Gear & Curved Teeth	7006EX	Caterpillar
151203R1	4 Cyl. 2.5L (152) (w/Auto Fan)	7312X	International/Navistar
151203R1	3.2L (196) (Models w/o Fan Clutch)	7312X	International/Navistar
151203R1	2.5L (152) (w/Auto Fan)	7312X	International/Navistar
151203R1	5.0L (304), 5.6L (345), 6.4L (392) (Models w/o Fan Clutch)	7312X	International/Navistar
151203R1	4.4L (266), 5.0L (304) (Models w/o Fan Clutch)	7312X	International/Navistar
151203R1	4.4L (266), 5.0L (304) (Models w/o Fan Clutch)	7312X	International/Navistar
151203R1	4.4L (266), 5.0L (304) (Models w/o Fan Clutch)	7312X	International/Navistar
151203R1	4.4L (266)	7312X	International/Navistar
151203R1	4.4L (266), 5.0L (304) (Models w/o Fan Clutch)	7312X	International/Navistar
151203R1	4.4L (266), 5.0L (304) (Models w/o Fan Clutch)	7312X	International/Navistar
151203R1	3.2L (196) (Models w/o Fan Clutch)	7312X	International/Navistar
151203R1	3.2L (196) w/Auto Fan	7312X	International/Navistar
151203R1	2.5L (152) w/Auto Fan	7312X	International/Navistar
151203R1	5.0L (304), 5.6L (345) (Models w/o Fan Clutch)	7312X	International/Navistar
151203R1	4.4L (266), 5.5L (304), 5.6L (345), 6.4L (392) (Models w/o Fan Clutch)	7312X	International/Navistar
151203R1	4.4L (266)	7312X	International/Navistar
151203R1M	3.2L (196) (Models w/Fan Clutch)	7326X	International/Navistar
151203R1M	5.0L (304), 5.6L (345), 6.4L (392) (Models w/Fan Clutch)	7326X	International/Navistar
151203R1M	4.4L (266), 5.0L (304) (Models w/Fan Clutch)	7326X	International/Navistar
151203R1M	4.4L (266), 5.0L (304) (Models w/Fan Clutch)	7326X	International/Navistar
151203R1M	4.4L (266), 5.0L (304) (Models w/Fan Clutch)	7326X	International/Navistar
151203R1M	4.4L (266), 5.0L (304) (Models w/Fan Clutch)	7326X	International/Navistar
151203R1M	4.4L (266), 5.0L (304) (Models w/Fan Clutch)	7326X	International/Navistar
151203R1M	3.2L (196) (Models w/ Fan Clutch)	7326X	International/Navistar
151203R1M	5.0L (304), 5.6L (345) (Models w/Fan Clutch)	7326X	International/Navistar
151203R1M	4.4L (266), 5.5L (304), 5.6L (345), 6.4L (392) (Models w/o Fan Clutch)	7326X	International/Navistar
161-5718	3406E, C15, C16 w/Straight Tooth Dome Gear	7006EGX	Caterpillar
169304R1	BC160 To 180 Series, D301 Diesel B	7325X	International/Navistar
172-7827	3306 Straight Teeth w/Off Set Holes	7007GX	Caterpillar
172-7829	3306 Angled Teeth w/Off Set Holes & 3 1/8" Bearing	7007X	Caterpillar

176-6999	3176B, C10, C12, C13 Acert Cast Iron Housing	7011X	Caterpillar
181094H	V/VT/VTA 1710	7078X	Cummins Diesel
1821935C1	7.6L (466) Navistar Diesel 2554, 2574, 2654, 2674, 8100, 8200, 8300 Forward Control Series; 3600, 3700, 3800, 3900FC Bus Chassis Series	7313X	International/Navistar
1821935C1	8.6L (530) Navistar Diesel 1400, 1452, 1600, Metro, 1652, 2554, 2654, 4500, 4600, 8200, 8300, Forward Control Series DT	7313X	International/Navistar
1821935C3	7.6L (466) Navistar Diesel 2554, 2574, 2654, 2674, 8100, 8200, 8300 Forward Control Series; 3600, 3700, 3800, 3900FC Bus Chassis Series	7313X	International/Navistar
1821935C3	8.6L (530) Navistar Diesel 1400, 1452, 1600, Metro, 1652, 2554, 2654, 4500, 4600, 8200, 8300, Forward Control Series DT	7313X	International/Navistar
1822823C1	7.3L (466) (F) E250/350 Direct Injection Turbo Diesel	7314X	Ford Truck
1822823C1	7.3L (466) (F) F250/350 Direct Injection Turbo Diesel	7314X	Ford Truck
1822823C1	7.3L (446) Direct Injection Turbo Diesel	7314X	Ford Truck
1822823C1	7.3L (446) (F) Direct Injection Turbo Diesel	7314X	Ford Truck
1822851C1	7.3, T444E Bus/Truck Diesel	7315X	International/Navistar
1822851C1	DI-T444E Bus (7.3L)	7315X	International/Navistar
1823423C2	7.3L (466) (F) E250/350 Direct Injection Turbo Diesel	7314X	Ford Truck
1823611C1	7.3L (446) (F) Direct Injection Turbo Diesel	7320X	Ford Truck
1823611C1	7.3L (466) (F) E350 Direct Injection Turbo Diesel	7320X	Ford Truck
1823611C1	7.3L (466) (F) E250/350 Direct Injection Turbo Diesel	7320X	Ford Truck
1823611C1	7.3 (446) (F) Diesel	7320X	Ford Truck
1823611C1	7.3L (466) (F) F250/350 Direct Injection Turbo Diesel	7320X	Ford Truck
1823611C1	7.3L (446) (F) Direct Injection Turbo Diesel	7320X	Ford Truck
1831005C2	7.3L (446) (F) Direct Injection Turbo Diesel	7320X	Ford Truck
1831005C2	7.3L (466) (F) E250/350 Direct Injection Turbo Diesel	7320X	Ford Truck
1831005C2	7.3 (446) (F) Diesel	7320X	Ford Truck
1831005C2	7.3L (466) (F) F250/350 Direct Injection Turbo Diesel	7320X	Ford Truck
1831005C2	7.3L (446) (F) Direct Injection Turbo Diesel	7320X	Ford Truck
1831005C2, 1823611C1	7.3L (466) (F) E350 Direct Injection Turbo Diesel	7320X	Ford Truck
1831576C1	F650/750	7322X	Ford Truck
1831576C1	7.3, T444E Bus/Truck Diesel	7322X	International/Navistar
1831676C91	7.3, T444E Bus/Truck Diesel	7315X	International/Navistar
1831676C91	DI-T444E Bus (7.3L)	7315X	International/Navistar
1841765C1	DT466 & 530E New Generation (7.6L)	7321X	International/Navistar
1927-10	5.9L (360) Cummins Turbo Diesel	7063X	Dodge Trucks
1927-10	5.9L (360) Cummins Turbo Diesel	7063X	Dodge Trucks
1W4619	3306 Reminds you of 7007 Except has 2 3/8" Bearing	7013X	Caterpillar
1W4619	3306 w/Solid Gear & 2 11/16" Bearing Similar to 7007	7014X	Caterpillar
1W9619	3306 Angled Teeth w/Off Set Holes & 3 1/8" Bearing	7007X	Caterpillar
1W9619	3306 Straight Teeth w/Off Set Holes	7007GX	Caterpillar
203-6093-01	Similar to 7016M Except has Hub	7016X	Caterpillar
203-6093-01	C7, 3126 w/Multi Groove Pulley	7016MX	Caterpillar
2201-10	ISX eng. Has 10 Groove Pulley at Top Step	7083X	Cummins Diesel
2201-10MJ	ISX eng. Has 12 Groove Pulley at Top Step	7084X	Cummins Diesel
224-3237	C17, C18 Acert, C27, Reminds you of 7006EG except Larger Housing, w/Straight Teeth Dome Gear	7017X	Caterpillar
23523972M	60 Series Accessory Drive	9163X	Detroit Diesel Accessory Drives
2370-10C	ISC & ISL series, Similar to 7076 except has Larger Casting at Mount w/Larger Impeller.	7082X	Cummins Diesel
2379-12	Asep w/5 1/4" Pulley	7230X	Mack

2379-12	Granite CV13, eng 460 E Tech. Same as 7230X Except has Larger Pulley O.D.	7230LX	Mack
246-3131	C17, C18 Acert, C27, Reminds you of 7006EG except Larger Housing, w/Straight Teeth Dome Gear	7017X	Caterpillar
246-3137	C17, C18 Acert, C27, Reminds you of 7006EG except Larger Housing, w/Straight Teeth Dome Gear	7017X	Caterpillar
2857-10C	ISC & ISL series, Similar to 7076 except has Larger Casting at Mount w/Larger Impeller.	7082X	Cummins Diesel
2M28	Tall Housing	7901X	Hino Truck
2P671	3304 w/Straight Holes & 2 11/16" Bearing	7010X	Caterpillar
303394R1	SP-375 Windrower w/C175	7325X	International/Harvester
303394R1	SP-315 w/D236	7325X	International/Harvester
303394R1	SP-616, 622 Cotton Picker w/C301	7325X	International/Harvester
303394R1	SP-205, 315w/C221	7325X	International/Harvester
303394R1	SP-403 w/C263, C282, D282 (To Serial # 2195)	7325X	International/Harvester
303394R1	SP-303 w/C221 (From Serial # 7278)	7325X	International/Harvester
303394R1	SP-503 w/D301	7325X	International/Harvester
303394R1	100C LDR	7325X	International/Harvester
303394R1	3600A w/C263	7325X	International/Harvester
303394R1	D50, w/C301, H-50, A, B, C, w/D188, UD236, UD282, D301	7325X	International/Harvester
303394R1	H-50, A, B, C, w/D188, UD236, UD282, D301	7325X	International/Harvester
303394R1	9000 w/C291, C301	7325X	International/Harvester
303394R1	3800, 3850 w/C263	7325X	International/Harvester
303394R1	H-60B w/C301	7325X	International/Harvester
303394R1	TD9B & 150 LDR	7325X	International/Harvester
303394R1	2500 Consall	7325X	International/Harvester
303394R1	T & TD7	7325X	International/Harvester
303394R1	2656 w/C263 & 3616 w/C221	7325X	International/Harvester
303394R1	4 Cyl. Gas 504, 2504 Models	7325X	International/Harvester
303394R1	6 Cyl. Gas 856, 2856 Models & 6 Cyl. Power Units UC221, 263, 291, UD188, 236, 282	7325X	International/Harvester
303394R1	2706 w/C263, 291, 2756 w/C291, 2856 w/C301, H-25 PL w/D188, H-30 w/236, 282, H-40 w/V264-6A, TD62 w/263	7325X	International/Harvester
303394R1	Farmall 460 Diesel	7325X	International/Harvester
303394R1	Farmall 460, 560, 660 Gas Models	7325X	International/Harvester
303394R1	Models: H70, H86, 2606, 2706, 2756, 403, 460, 560, 606, 660, 706, 766, 806, 826, 856	7325X	International/Harvester
303394R1	BC160 To 180 Series, D301 Diesel B	7325X	International/Navistar
3045163, Made in UK 93810	300, 350, 400, Fleet 300, NTC-Formula 300, 350 400 (w/4 1/2" Multi Groove Pulley & 4 1/2" Impeller) Vented	7064X	Cummins Diesel
3064201R	NTC-300, 315, 350, 365, 400, Idler w/Multi Groove Pulley	7069X	Cummins Diesel
3064201R	Multi Groove Idler Pulley	7067X	Cummins Diesel
306GB334	Thermodyne 673, 675, 711, Short Shaft, No Pulley w/Stamped Steel Impeller	7204X	Mack
330813P	5.7L (350), Series 40, 50, 60	7146X	Chevrolet Truck
360GB251AM	E7 w/3 Belt Pulley, 7 1/4" O.D. & Metric Housing, w/Stamped Impeller (Short Shaft)	7217X	Mack
360GB251AM	E7 w/3 Belt Pulley, 5 1/2" O.D. & Metric Housing, w/Stamped Impeller (Short Shaft)	7218X	Mack
360GB251AM	E7 Metric Housing & No Pulley, Short Shaft w/Stamped Impeller	7220X	Mack
360GB251AM	E7, Long Shaft w/3 Belt Long Pulley & Metric Housing (Long Shaft)	7222X	Mack
360GB251AM	E7, 3 Belt Pulley w/6 5/8" O.D. & Metric Housing (Short Shaft)	7223X	Mack



360GB251AM	E7, Long Shaft w/3 Belt Long Pulley & Metric Housing (Long Shaft)	7224X	Mack
360GB251AM	E7, Metric Housing & No Pulley, Long Shaft	7225X	Mack
360GB251AM	E7 w/5 1/2" Multi Groove Pulley & 1 V Belt Pulley (Short Shaft)	7226X	Mack
360GB251AM	E7 w/6 5/8" Multi Groove Pulley & 1 V Belt Pulley (Short Shaft)	7227X	Mack
360GB334	END 673, 675, 676, Short Shaft, No Pulley, w/Cast Iron Impeller	7201X	Mack
360GB334	END 673, 675, 676, w/Hub, Short Shaft w/Stamped Steel Impeller	7206X	Mack
360GB443A	Maxidyne ESI, ENDT 675, 676, Long Shaft, No Pulley, w/Cast Iron Impeller	7202X	Mack
360GB443A	Maxidyne ESI, ENDT 675, 676, Long Shaft, No Pulley, w/Stamped Steel Impeller	7205X	Mack
360GB443A	Econodyne Charged Air E6, EM6, EMS 6, No Pulley, w/Stamped Steel Impeller	7208X	Mack
360GB443A	Econodyne Charged Air E6, EM6, EMS 6, w/3 Belt Pulley, w/Stamped Steel Impeller	7209X	Mack
360GB443A	E6 Charged Air, w/3 Groove Pulley & Stamped Steel Impeller	7210X	Mack
360GB443A	Maxidyne ESI, ENDT 675, 676, Long Shaft, w/3 Groove Pulley, w/Stamped Steel Impeller	7211X	Mack
360GB443A	Maxidyne ESI, ENDT 675, 676, Long Shaft, w/4 Groove Pulley, w/Stamped Steel Impeller	7212X	Mack
360GB443A	Maxidyne ENDT 675, 676, Long Shaft, w/Pulley	7214X	Mack
360GB443A	675 ESI, ENDT, Long Shaft, w/Notched Pulley for Fan Clutch Applications	7215X	Mack
360GB443A	Econodyne, E7, w/Flat Bottom Impeller, No Pulley	7216X	Mack
360GB443A	E6 w/3 Belt Pulley, 7 1/4" O.D. w/Stamped Impeller & B Housing (Short Shaft)	7219X	Mack
360GB443B	E6, 6 5/8" Pulley w/3 Belts and Flat Impeller & B Housing	7221X	Mack
360GB52M	E7 w/6 1/4" Multi Groove Pulley & 1 V Belt Pulley (Short Shaft)	7228X	Mack
360GB52M	E7 w/Long Multi Groove Pulley (Long Shaft)	7229X	Mack
360GB54M	E7 Serial number DM690S28406. Same as 7220X Except has Heavy Duty Bearing	7231X	Mack
37711330B	MF-135, MF-150, MF-2135, Using Perkins Diesel Eng.	7088	Massey-Ferguson, Massey-Harris
37711330B	MF-35, MF-50, MF203, MF-205, Using Perkins Diesel Eng.	7089	Massey-Ferguson, Massey-Harris
37711330B	Engine AD3-153	7088	Perkins Engine Heavy Duty
446430C1	7.3L (446) (M) E250/350, Diesel Non-Turbo	7304X	Ford Truck
446430C1	6.9L (420) (1) 7.3L (446) (M) E250/350 Diesel	7304X	Ford Truck
446430C4	7.3L (466) (K) F250/350 Indirect Injection Turbo Diesel	7304X	Ford Truck
446430C4	7.3L (466) (M) F250/350 Diesel Non-Turbo	7304X	Ford Truck
446430C4	7.3L (466) (C) F250/350 Turbo Diesel	7304X	Ford Truck
446430C4	6.9L (420) (1) 7.3L (446) (Diesel) F250/350	7304X	Ford Truck
446430C4	7.3L (466) (K) Indirect Injection Turbo Diesel	7304X	Ford Truck
446430C4	7.3L (466) (M) Diesel Non Turbo	7304X	Ford Truck
44643C1	7.3L (445) Navistar Diesel 1400 Metro, 1452, 1600, 1652 Forward Control Series	7305X	International/Navistar
44643C1	7.3L (445) Navistar Diesel 3600, 3700, 3800, 3900FC Bus Chassis Series, 4500, 4600	7305X	International/Navistar
44643C1	6.6L (404), 6.9L (420), 7.3 (446) ,Cargostar, S Medium Series Gas & Diesel	7305X	International/Navistar
489173C1	9.0L (552) Diesel S Series Medium Duty	7308X	International/Navistar
489173C1	9.0L (552) Diesel Cargostar	7308X	International/Navistar



4P3681	3116 w/4 3/8" Pulley	7012X	Caterpillar
4P3681	3116 w/Fittings	7012KX	Caterpillar
4W0249	3116 w/3 3/4" Pulley	7015X	Caterpillar
675806C2	815, 915 w/D414, DT414 Diesel	7303X	International/Harvester
675806C2	All w/D436, DT436 Diesel	7303X	International/Harvester
675806C2	All w/D466, DT466	7303X	International/Harvester
675806C2	966, 1066, 1086, D414, DT414, D436, DT436, D466, DT466 Diesel	7303X	International/Harvester
675806C3	815, 915 w/D414, DT414 Diesel	7303X	International/Harvester
675806C3	All w/D436, DT436 Diesel	7303X	International/Harvester
675806C3	All w/D466, DT466	7303X	International/Harvester
675806C3	966, 1066, 1086, D414, DT414, D436, DT436, D466, DT466 Diesel	7303X	International/Harvester
677137C1	7.6L (466) Cab Over Models	7312X	International/Navistar
677137C1	DT466 7.6L (466) Cab over	7302X	International/Navistar
677856C1	7.6L (466) Conventional Models, DT466 (B)	7301X	International/Navistar
677856C1	5.9L (366) DT/DTA Diesel, 7.6L (466) DT/DTA Diesel 1600, 1652, 4500, 4700, 4800, 4900, 7100; Bus Chassis Series 3600, 3700, 3800, 3900CF	7310X	International/Navistar
677856C1	7.6L (466) Navistar Diesel 2554, 2574, 2654, 2674, 8100, 8200, 8300 Forward Control Series (w/o Electronically Controlled Emissions)	7310X	International/Navistar
677856C1	7.6L (466) Navistar Diesel (From 10/4/91) 2554, 2574, 2654, 2674, 8100, 8200, 8300	7310X	International/Navistar
677856C1	7.6L (466) Navistar Diesel To 10/4/91, 2554, 2574, 2654, 8100, 8200, 8300	7301X	International/Navistar
677856C1	5.9L (360) FD1060 Cummins Diesel, 1452, 1624, 1654, 1723, 1724, 1753, 1754, 1824, 1853, 1854, 1924, 1925, 1954, 1955, 2125, 2155	7301X	International/Navistar
677856C1	7.6L (466) Navistar Diesel 1452, 1624, 1654, 1723, 1724, 1753, 1754, 1823, 1824, 1853, 1854, 1924, 1925, 1954, 1955, 2125, 2155 Forward Control Series	7301X	International/Navistar
677856C2	7.6L (466) Conventional Models, DT466 (B)	7301X	International/Navistar
677856C2	7.6L (466) Navistar Diesel To 10/4/91, 2554, 2574, 2654, 8100, 8200, 8300	7301X	International/Navistar
677856C2	5.9L (360) FD1060 Cummins Diesel, 1452, 1624, 1654, 1723, 1724, 1753, 1754, 1824, 1853, 1854, 1924, 1925, 1954, 1955, 2125, 2155	7301X	International/Navistar
677856C2	7.6L (466) Navistar Diesel 1452, 1624, 1654, 1723, 1724, 1753, 1754, 1823, 1824, 1853, 1854, 1924, 1925, 1954, 1955, 2125, 2155 Forward Control Series	7301X	International/Navistar
677856C3	5.9L (366) DT/DTA Diesel, 7.6L (466) DT/DTA Diesel 1600, 1652, 4500, 4700, 4800, 4900, 7100; Bus Chassis Series 3600, 3700, 3800, 3900CF	7310X	International/Navistar
677856C3	7.6L (466) Navistar Diesel 2554, 2574, 2654, 2674, 8100, 8200, 8300 Forward Control Series (w/o Electronically Controlled Emissions)	7310X	International/Navistar
677856C3	7.6L (466) Navistar Diesel (From 10/4/91) 2554, 2574, 2654, 2674, 8100, 8200, 8300	7310X	International/Navistar
7N196	3306 Angled Teeth w/Off Set Holes & 3 1/8" Bearing	7007X	Caterpillar
7N196	3306 Straight Teeth w/Off Set Holes	7007GX	Caterpillar
7N196	3306 Reminds you of 7007 Except has 2 3/8" Bearing	7013X	Caterpillar
7N196	3306 w/Solid Gear & 2 11/16" Bearing Similar to 7007 (Straight Teeth, 7014GX)	7014X	Caterpillar
8922723-7		7125	Detroit Diesel
9L8323	1140 & 1160, Models: 1500, 1800 w/3150 eng.	7005X	Caterpillar
9N138	3208 w/press on pulley	7008X	Caterpillar

9N3076	3208, 636 Cu. Inch Eng. With No Pulley	7001X	Caterpillar
9N3076	3208, 636 Cu. Inch Eng. w/pulley	7002X	Caterpillar
9N3076	3208, 636 Cu. Inch Eng. Threaded Pulley for Fan Clutch.	7004X	Caterpillar
9N5034	3406 B&C, 893 Cu. Inch. Flat Gear w/curved Teeth	7006X	Caterpillar
9N5034-01	3406E w/Dome Gear & Curved Teeth	7006EX	Caterpillar
A-28860	Model 150 w/400 Eng.	7030X	Case
A-28860	Model 600 w/G188B Eng.	7030X	Case
A-28860	310D, 310F Utility, 430, 440, 530, 540, 540C, 541, 541C Gas Models	7030X	Case
A-28860	200B, 210B, 300B, 310B, 400B, 500B, 600B, 610B Gas Models	7030X	Case
A-28860	200, 210, 300, 310, 400, 500, 600, 610 Gas Models	7030X	Case
A-28860	300, 320, 350, 351 Gas Models	7030X	Case
A-28860	VA, VAC Series (After No. 72-E07778	7030X	Case
C5NE-8505A	8000, 8200, 8400	7337X	Ford Tractor & Industrial
C5NE-8505A	9000, 9200	7337X	Ford Tractor & Industrial
C5NE-8508A	2000, 3000, 4000 Series Gas or Diesel (w/Single Groove Pulley & 3.500 Dia. Impeller)	7331X	Ford Tractor & Industrial
C5NE-8508A	5000 Gas or Diesel (w/Single Groove Pulley & 3.500 Dia. Impeller) (Can Use 7330X)	7331X	Ford Tractor & Industrial
D4NN-8508A	All 2000 thru 7000 Series Gas or Diesel (w/Single Groove Pulley & 4.100" Impeller)	7330X	Ford Tractor & Industrial
D4NN-8508A	All 2000 thru 7000 Series Gas or Diesel (w/Single Groove Pulley & 4.100" Impeller)	7330X	Ford Tractor & Industrial
D5NN-8505A	All 2000 thru 7000 Series Gas or Diesel (w/Single Groove Pulley & 4.100" Impeller)	7330X	Ford Tractor & Industrial
D5NN-8505A	All 2000 thru 7000 Series Gas or Diesel (w/Single Groove Pulley & 4.100" Impeller)	7330X	Ford Tractor & Industrial
D8NN-8508EB	2000, 3000, 4000, 5000, 7000 (2600, 3600, 4100, 4600, 5600, 5700, 6600, 6700, 7600, 7700 (2310, 2610, 2810, 2910, 3610, 3910, 4110, 4610 All 2/90) w/5/16" & 7/16" Mounting Holes (2 Groove Pulley) (Large Bearing)	7340X	Ford Tractor & Industrial
D8NN-8508EB	6700 Thru 7700 w/5/16" & 3/8" Mounting Holes, Same as 7340 Except has Smaller Mounting Holes	7341X	Ford Tractor & Industrial
E2TE-8505AA	370, 429 B, F600/800	7309X	Ford Truck
E2TE-8505AA	370, 429 C, CT600/800	7309X	Ford Truck
E2TE-8505AA	370, 429 L, LN, LNT, LT, LTS800	7309X	Ford Truck
E4TE-AA	7.0L 370, 429	7309X	Ford Truck
E7HN-8508AA	6.6L (401) 7.8L (476) Diesel B-F-L600/L900	7307X	Ford Truck
E7HN-8508AA	6.6L (401) 7.8L (476) FNH Diesel	7307X	Ford Truck
E7HN-8508AA	6.6L (401) F600	7307X	Ford Truck
E7HN-8508AA	7.8L (476) CF600/800	7307X	Ford Truck
E7HN-8508AB	7.8L	7306X	Ford Truck
E8HN-8508AB	6.6L (401) B-C-CF-F800 (With Water Pump Mounted Fan)	7319X	Ford Truck
E8HN-8508AB	6.6L (401) C600/F800 Diesel (With Water Pump Mounted Fan, Exc. 210 H.P)	7319X	Ford Truck
E8HN-8508AB	6.6L (401) 7.8L (476) Diesel B-F-FT-L600/L900 (From 10/1/90) (With Water Pump Mounted Fan) (Exc. 210 H.P)	7319X	Ford Truck
E8NN-8505	Models (5110, 5610, 6610, 6810, 7410, 7610, 7710 All 11/88 & Up) 7010 4/96 & UP (All w/Threaded 2 Belt Pulley)	7333X	Ford Tractor & Industrial
EAF-8505	134, 172 Tractor & Industrial gas Models 600, 700, 800, 900, 2000, 4000 Series Diesel Models	7334X	Ford Tractor & Industrial
EAF-8505	Series 500D, 501D, After Serial #153775; 600D, 601D, 700D, 701D, 2030D, 2031D, 2110D, 2111D, 2120D, 2130D, 2131D w/144 Diesel	7334X	Ford Tractor & Industrial

EAJ-8505	Series 800D, 801D, 900D, 901D, 1800, 4030D, 4031D, 4040D, 4110D, 4120D, 4121D, 4130D, 4131D, 4140D w/D172 Diesel	7334X	Ford Tractor & Industrial
EAJ-8505	Series 800, 801, 900, 901, 1800, 1801, 4030, 4031, 4040, 4110, 4121, 4130, 4131, 4140 w/172 Gas or L.P.G	7334X	Ford Tractor & Industrial
EAJ-8505	Series NAA, 501, 541, 600, 601, 611, 620, 621, 630, 631, 640, 641, 650, 651, 660, 661, 671, 700, 701, 740, 741, 771, 2030, 2031, 2110, 2111, 2120, 2130, 2131 w/134 Gas or L.P.G.	7334X	Ford Tractor & Industrial
EAJ-8505	Series NAA, 600, 620, 621, 630, 631, 640, 641, 650, 651, 660, 661, 700, 740, 741 w/134 Kerosene Eng.	7334X	Ford Tractor & Industrial
EAJ-8505	800K, 900K w/172 Kerosene Eng.	7334X	Ford Tractor & Industrial
EAP-8A513-E	2000, 3000, 4000, 5000, 7000 (2600, 3600, 4100, 4600, 5600, 5700, 6600, 6700, 7600, 7700 (2310, 2610, 2810, 2910, 3610, 3910, 4110, 4610 All 2/90) w/5/16" & 7/16" Mounting Holes (2 Groove Pulley) (Large Bearing)	7340X	Ford Tractor & Industrial
EAP-8A513-E	6700 Thru 7700 w/5/16" & 3/8" Mounting Holes, Same as 7340 Except has Smaller Mounting Holes	7341X	Ford Tractor & Industrial
F162K500	Continental Eng. F226, F227, F244, F245, w/2 Groove Pulley	7034X	Allis Chalmers
F162K500	Continental Eng. F226, F227, F244, F245, w/2 Groove Pulley	7034X	Caterpillar
F1HE-8505CA	7.0L 370, 429	7309X	Ford Truck
F400K-422	Continental Series F162 Engine Pump w/Back Plate and 2 Groove Pulley	7035X	Clark Truck & Tractor, (4Cyl.)
F400K-422	Series F162 Pump Using F400K-422 Body, w/Back Plate and 2 Groove Pulley HD206K-305	7035X	Continental Motors, (4Cyl.)
F5HE-8505AA	7.0L (429) CF800, CFT800 (LPG Gas Only)	7309X	Ford Truck
F600K519	Continental Eng. F163, w/3 Groove Pulley	7033X	Allis Chalmers
F600K519	Continental Eng. F163, w/3 Groove Pulley	7033X	Caterpillar
F600K520	Continental Eng. F162, w/2 Groove Pulley	7032X	Allis Chalmers
F600K520	Continental Eng. F162, w/2 Groove Pulley	7032X	Caterpillar
F6TE-8505LA	4.9L (300) Industrial Eng.	7336X	Ford Tractor & Industrial
FOHN-8508AA	6.6L (401) B-C-CF-F800 (w/out Water Pump Mounted Fan)	7311X	Ford Truck
FOHN-8508AA	6.6L (401) C600/F800 Diesel (w/out Water Pump Mounted Fan, Exc. 210 H.P)	7311X	Ford Truck
FOHN-8508AA	6.6L (401) 7.8L (476) Diesel B-F-FT-L600/L900 (From 10/1/90) (w/out Water Pump Mounted Fan)	7311X	Ford Truck

## **WATER PUMP DAMAGES**

**Deductions for each broken or missing component listed, is not to exceed 100% of core value.**

<b>Pulley or Hub Missing or Damaged</b>	<b>Gear/Drive Coupling Missing or Damaged</b>	<b>Cover Missing or Damaged</b>
<b>30%</b>		
	<b>60%</b>	
	<b>40%</b>	
<b>50%</b>		
<b>20%</b>		<b>40%</b>
<b>60%</b>		<b>40%</b>

*Caterpillar 3208 cores must be new style large diameter bore (outside 3.5") bolt on pulley.  
No credit will be given for old style diameter bore (outside 2")*

*All Detroit Diesel V71 & V92 cores returned for credit must have an oil cooler provision  
V71 & V92 Cores WITHOUT oil cooler provision have no value.*

*Cores that are generic (not remanufactured by BEPCO, Inc ,or Original Manufacturer) are no value and indicated by an "XO" at the end of the part number. Ex: 7126XO*



***CATERPILLAR®***

***CUMMINS®***

***DETROIT DIESEL®***

***GENERAL MOTORS®***

***FORD®***

***INTERNATIONAL®***

***MACK®***

***THERMO-KING®***



# **BEPCO, Inc**

**2475 S STRATFORD ROAD  
WINSTON SALEM, NC 27103**

**800-735-1154 336-760-0740**

***fax 336-768-3756***